

User manual

Cliniclave[®] 45 D Cliniclave[®] 45 MD

Large steam sterilizer

from software version 3.240



EN

Dear customer,

We thank you for your confidence demonstrated by the purchase of this MELAG product. As an owner-run and operated family concern founded in 1951, we have a long history of successful specialization in hygiene products for practice-based use. Our focus on innovation, quality and the highest standards of operational reliability has established MELAG as the world's leading manufacturer in the instrument reprocessing and hygiene field.

You, our customer are justified in your demand for the best products, quality and reliability. Providing **“competence in hygiene”** and **“Quality – made in Germany”**, we guarantee that these demands will be met. Our certified quality management system is subject to close monitoring: one instrument to this end is our annual multi-day audit conducted in accordance with EN ISO 13485. This guarantees that all MELAG products are manufactured and tested in accordance with strict quality criteria.

The MELAG management and team.

CE 0197

Contents

1 General guidelines	5	Selecting the program	25
Symbols used	5	Additional program options	28
Formatting rules	5	Additional drying	28
Disposal	5	Start time pre-selection	28
2 Safety	6	Automatic shutdown	29
3 Performance specifications	7	Starting the program	29
Intended use	7	Program run	30
Sterilization procedure	7	Manual program abort	31
Type of the feed water supply	7	Program abort before the start of drying	31
Safety equipment	7	Program abort after the start of drying	33
Program runs	8	Program end	34
4 Description of the device	9	The approval process	34
Scope of delivery	9	Removing the sterile material	35
Views of the device	10	Enable the loading side	35
Symbols on the device	12	Storing sterile material	35
Colour touch display	13	8 Logging	36
LED status bar	14	Batch documentation	36
Mounts for the load	15	Output media	36
5 First steps	16	Using the CF card as an output medium	36
Setup and installation	16	Using the computer as an output medium	37
Feed water supply	16	Label printer as output medium	38
Use of high quality feed water	16	Outputting text logs automatically after program end (immediate output)	38
The feed water supply in the steam sterilizer	16	Subsequent log output	39
Switch on the device	17	Finding logs	41
Opening and closing the door	17	9 Function checks	43
Opening the door	18	Vacuum test	43
Closing the door	18	Bowie & Dick test	43
Manual door emergency-opening	18	MELAcontrol Helix and MELAcontrol Pro test body system	44
6 Loading the steam sterilizer	20	Feed water quality	44
Preparing the load	20	Validation	44
Reprocessing textiles	20	Renewed performance qualification (requalification)	44
Reprocessing instruments	20	10 Settings	45
Loading the steam sterilizer	21	Setting the display position	45
Closed sterile containers	21	Logging	45
Soft sterilization packaging	21	Immediate log output	45
Multiple wrapping	22	Outputting graphic logs (optional)	46
Mixed loads	22	Log output in English	47
Load quantities and versions	22	Using the computer as an output medium	48
Loading system Comfort	23	IP addresses	49
7 Sterilization	24	Log formats	50
Important information regarding routine operation	24	User administration	51
Daily routine checks	24	Adding a user	51
Further routine checks	24		



Deleting a user.....	52	Replacing of the door gasket.....	63
Changing the Admin PIN	52	Checking and oiling the door lock.....	63
User authentication for sterilization.....	53	Replacing the sterile filter	64
Formatting the CF card	54	Maintenance	64
Additional drying.....	55	Maintenance of the reverse osmosis unit.....	64
Intelligent drying	56	12 Pause times	65
Date and time	56	Frequency of sterilization.....	65
Brightness	57	Duration of the operating pause	65
Volume	57	Decommissioning	65
View	58	Emptying the double jacket	66
Key tone.....	59	Transport	66
Screensaver	59	Preparing the steam sterilizer for transport	66
Log printer MELAprint 42/44	60	Transport within the practice	67
MELAprint 60 label printer.....	60	Transport over long-distance / dispatch	67
Sensitivity	60	Recommissioning after relocation	68
Energy-saving mode	61	13 Malfunctions.....	69
Switching off the display	61	Messages	69
11 Maintenance.....	62	Warning and malfunction messages	70
Servicing intervals	62	14 Technical data	82
Cleaning	62	15 Accessories and spare parts.....	84
Sterilization chamber, door gasket, mount, trays.....	62	Glossary	86
Housing parts.....	63		
Avoiding staining	63		

1 General guidelines



Please read this user manual carefully before commissioning the device. The manual includes important safety instructions. Make sure that you always have access to digital or printed version of the user manual.

Should the manual no longer be legible, is damaged or has been lost, you can download a new copy from MELAG download centre at www.melag.com.

Symbols used

Symbol	Description
 WARNING	Indicates a dangerous situation, which if not avoided, could entail slight to life-threatening injuries.
 CAUTION	Indicates a dangerous situation, which if not avoided, could entail slight to moderate injuries.
NOTICE	Indicates a dangerous situation, which if not avoided, could result in damage to the instruments, the practice fittings or the device.
 PLEASE NOTE	Draws your attention to important information.

Formatting rules

Example	Description
see Chapter 2	Reference to another text section within this document.
Log	Words or phrases appearing on the display of the device are marked as display text.
	Prerequisites for the following handling instruction.
	Reference to the glossary or another text section.
	Information for safe handling.

Disposal

MELAG devices are synonymous with long-term quality. When you eventually need to decommission your MELAG device, the required disposal of the device can be carried out by MELAG in Berlin. Simply contact your stockist.

Dispose of ▶[components](#), spare parts, ▶[accessories](#), ▶[equipment](#) and consumables that you no longer need properly. Comply with all relevant disposal regulations regarding potentially contaminated waste.

The packaging protects the device against transport damage. The packaging materials have been selected for their environmentally-friendly and recycling properties and can be recycled. Returning the packaging to the material cycle reduces the amount of waste and saves raw materials.

MELAG draws the operator's attention to the fact that they are responsible for deleting personal data on the device to be disposed of.

MELAG draws the operator's attention to the fact that they may be legally obliged (e.g. in Germany according to ElektroG) to remove used batteries and accumulators non-destructively before handing over the device, provided they are not enclosed in the device.

2 Safety



When operating the device, comply with the following safety instructions as well as those contained in subsequent chapters. Use the device only for the purpose specified in these instructions. Failure to comply with the safety instructions can result in injury and/or damage to the device.

Qualified personnel

- As with the preceding instrument reprocessing, only [▶competent personnel](#) should undertake sterilization using this steam sterilizer.
- The operator must ensure that the users are regularly trained in the operation and safe handling of the device.

Power cable and power plug

- Only the power cable included in the scope of delivery may be connected to the device.
- The power cable may only be replaced by an original spare part from MELAG.
- Comply with all legal requirements and locally-specified connection conditions.
- Never operate the device if the plug or power cable are damaged.
- The power cable or plug should only be replaced by [▶authorised technicians](#).
- Never damage or alter the power plug or cable.
- Never bend or twist the power cable excessively.
- Never unplug by pulling on the power cable. Always take a grip on the plug.
- Never place any heavy objects on the power cable.
- Ensure that the power cable does not become jammed in.
- Never lead the cable along a source of heat.
- Never fix the power cable with sharp objects.
- The mains socket must be freely accessible after installation so that the device can be disconnected from the electrical mains at any time if necessary by pulling the mains plug.

Opening the housing

- Never open the device housing. Incorrect opening and repair can compromise electrical safety and pose a danger to the user. The device may only be opened by an [▶authorised technician](#) who must be a [▶qualified electrician](#).

Notification requirement in the event of serious incidents in the European Economic Area

- Please note that all serious incidents that occur in relation to a [▶medical device](#) (e.g. death or a serious deterioration in a patient's state of health), which were presumably caused by the device must be reported to the manufacturer (MELAG) and the competent authority of the member state in which the user and/or the patient resides.

3 Performance specifications

Intended use

The steam sterilizer is designed for application in a medical context (e.g. general practitioners and dental practices, outpatient surgeries, outpatient centres, walk-in healthcare centres, group practices and hospitals). This steam sterilizer is a large sterilizer in accordance with EN 285. As a universal steam sterilizer it is suitable for complex sterilization tasks performed on the basis of the fractionated vacuum procedure. This enables the complete and effective penetration of the ▶load with saturated steam. It can be used to sterilize large quantities of instruments with narrow lumen and transmission instruments – both wrapped or unwrapped – and textiles. Typical users are physicians, trained medical assistants, and service technicians.

▲ WARNING

Warning of material damage and injury

Any attempt to sterilize fluids can result in a ▶delay in boiling. This can cause damage to the device and/or scalding.

- Never use this device to sterilize fluids. It is not licensed for the sterilization of fluids.

Sterilization procedure

The steam sterilizer sterilizes on the basis of the ▶fractionated vacuum procedure. This guarantees the complete and effective wetting or penetration of the load with saturated steam.

This procedure enables the sterilization of loads produced in a doctor's practice or clinic in accordance with ▶EN 285.

The steam sterilizer uses double jacket technology to generate the sterilization steam, i.e. the steam sterilizer is fitted with a separate steam generator combined with a double-walled sterilization chamber. After heating, steam is held constantly available in the double jacket. This gives the walls of the sterilization chamber a defined temperature and protects the chamber itself from overheating.

This procedure supports the quick ▶evacuation of the air from the sterilization chamber, the sterilization packages and instrument cavities. This allows you to sterilize large quantities of instruments or textiles in a very short time and achieve very good drying results.

Type of the feed water supply

The device works with a feed water one-way system. It uses fresh ▶feed water in the form of ▶demineralised or ▶distilled water for each sterilization procedure. The quality of the feed water is subject to permanent monitoring via integrated ▶conductivity measurement. If combined with a proper preparation of the instruments, this serves largely to prevent stain accretion on the instruments and soiling of the device.

Safety equipment

Internal process monitoring

A ▶process evaluation system is integrated in the electronics of the device. It compares the process parameters, such as temperature, time and pressure, during a program run. It monitors the parameters in terms of their threshold values and ensures safe and successful reprocessing. A monitoring system checks the device components of the device for their functionality and their plausible interaction. If one or more parameters exceeds pre-determined threshold values, the device issues warning or malfunction messages and if necessary, aborts the program. In the case of a program abort, follow the instructions on the display.

The device works with an electronic parameter control. This serves to optimise the total operating time of a program in dependence on the load.

The device constantly checks pressure and temperature in the sterilization chamber and prevents the door from being opened during the program run and when over-pressure has built up. The motor-driven automatic door lock opens the door slowly by turning the door lock nut and holds the door whilst it opens. Pressure equalisation will have been performed by the time that the door is completely open, even following pressure differences.

Independent Registration Device (URG)

The process data is registered using an Independent Registration Device (URG). The process data is determined entirely independently from the control and documented in a log.

Quantity and quality of the feed water

The quantity and quality of the ►feed water is automatically checked before every program start.

Automatic emergency shutdown

The steam sterilizer is equipped with an emergency shut-down mechanism; i.e. the steam sterilizer shuts down automatically if the internal process evaluation system registers a fault which represents a particular hazard situation. Reactivation of the steam sterilizer is only possible after the malfunction has been remedied.

Program runs

A program runs in three main phases: the de-aeration and heating up phase, the sterilization phase and the drying phase. After program start, you can follow the program run on the display. It shows the chamber temperature and pressure as well as the time until the end of sterilization / drying.

Program phases of a standard reprocessing program

Program phase	Description
1. De-aeration and heating phase	<p>De-aeration</p> <p>The de-aeration phase comprises of the conditioning and the fractionating phase. During conditioning, steam is repeatedly injected into and removed from the ►sterilization chamber. This generates over-pressure and the residual air is removed. Then, during fractionation, the mixture of air and steam is evacuated from the sterilization chamber and steam is injected. This method is also called the fractionated vacuum procedure.</p>
	<p>Heating</p> <p>The continued steam injection into the sterilization chamber leads to an increase in pressure and temperature, which continues until the program-specific sterilization parameters have been reached.</p>
2. Sterilization phase	<p>Sterilizing</p> <p>If the pressure and temperature correspond to the program-dependent nominal values, the sterilization phase begins. The corresponding program parameters (pressure and temperature) are held at sterilization level. The plateau time is indicated on the display.</p>
3. Drying phase	<p>Pressure release</p> <p>The sterilization phase is followed by pressure release from the sterilization chamber.</p>
	<p>Drying</p> <p>The sterile material is dried using a vacuum, so-called vacuum drying.</p>
	<p>Ventilation</p> <p>Upon program end, the sterilization chamber is filled with sterile air via the air filter and adjusted to the ambient pressure. A corresponding display message Ventilation is shown.</p>

Program phases of the vacuum test

Program phase	Description
1. Evacuation phase	The sterilization chamber is evacuated until the pressure for the vacuum test has been reached.
2. Equilibration time	An equilibration time of 5 min will follow.
3. Measurement time	The measuring time is 10 min. The pressure increase within the sterilization chamber is measured during the measurement time. The evacuation pressure and the equilibration time or measurement time are shown on the display.
4. Ventilation	The sterilization chamber is ventilated after the end of the measuring time.
5. Test end	The display shows the test result, the batch number, the total number of batches and the leakage rate.

4 Description of the device

Scope of delivery

Please check the scope of delivery before setting up and connecting the device.

- Cliniclave 45 D or Cliniclave 45 MD
- User manual
- Technical manual
- Record of installation
- Manufacturer's inspection report and declaration of conformity
- Warranty certificate
- CF card
- Slide rail Basic or Slide rail Comfort
- Protective gloves
- 4x Carrying handle
- Transport bars set (only for separate dispatch of the device and floor unit)
- 4x Screw M12x12
- Outlet hose including two seals (2x with Cliniclave 45 MD)
- PTFE hose 8/6x600
- 2x PTFE hose 16/13x600
- Membrane grommet, large (24 mm, 2x with Cliniclave 45 MD)
- Membrane grommet, small (5 mm, 2x with Cliniclave 45 MD)
- Open-end spanner for the validation fitting connection/floor unit casters
- Ring spanner for the validation fitting retaining nut
- Allen key with which to open the door in an emergency
- MELAG oil for door lock nut
- Test gauge TR20 for door lock nut
- Test system for Bowie & Dick test
- Component set for wall installation (casing for wall breakthrough)
- Installation set (dispatched in advance)

Views of the device

PLEASE NOTE

Recognizing the loading and removal side of the steam sterilizer and the floor unit:

- The fan at the top of the steam sterilizer always lies on the loading side.
- Cliniclave 45 D: The door of the floor unit can only be opened on the loading side.
- Cliniclave 45 MD: A metal panel in the floor unit interior divides it into a loading and removal side. The deeper side is the loading side.

Front

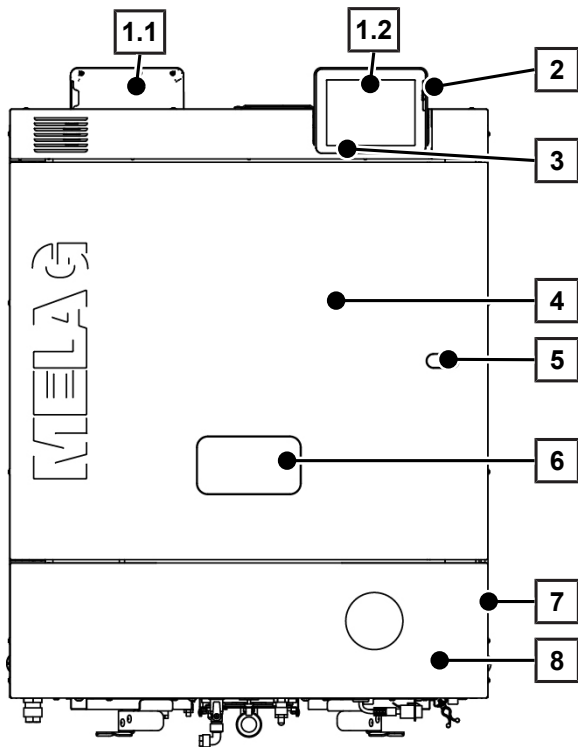

- 1.1 Colour touch display (removal side)
- 1.2 Colour touch display (loading side)
- 2 CF card slot
- 3 LED status bar
- 4 Door (swings open left/right)
- 5 Opening for door opening in an emergency*)
- 6 Validation fitting*)
- 7 Power switch (covered, accessible from the side)
- 8 Service hatch
- *) behind cover

Detailed view with service hatch open (loading side)

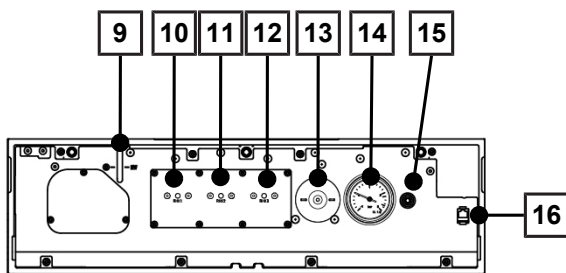

- 9 Steam generator level gauge
- 10 Reset button overheating protection RHK1 (safety temperature limiter)
- 11 Reset button overheating protection RHK2 (safety temperature limiter)
- 12 Reset button overheating protection RHK3 (safety temperature limiter)
- 13 Sterile filter
- 14 Manometer (double jacket steam generator)
- 15 Opening for emergency activation of the vacuum pump
- 16 Service connection of network cable (RJ45)

Detailed view with service hatch open (removal side)

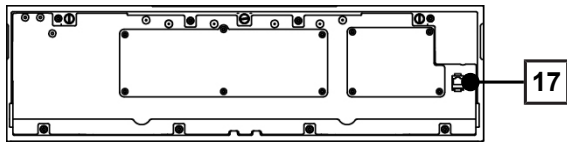

- 17 Network cable connection (RJ45) for service

Underside

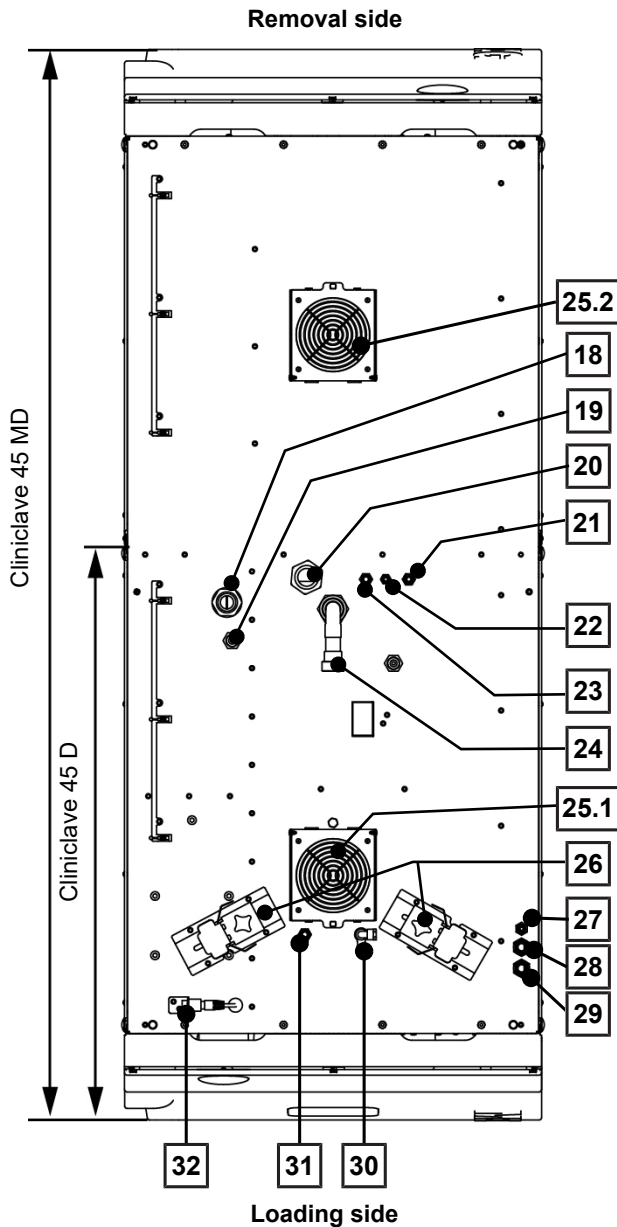

- 18 Power cable
 - 19 Power plug connection MELAdem 56/56 M
 - 20 Cold water connection (building side)
 - 21 Feed water connection, water treatment unit
 - 22 Connection of the concentrate line water treatment unit
 - 23 Cold water connection of water treatment unit
 - 24 Wastewater connection
 - 25.1 Fan
 - 25.2 Fan*)
 - 26 Bracket and tensioning carriage for outlet hose
 - 27 Emergency release hose connection
 - 28 Over-pressure line of the spring safety valve "Double jacket"***)
 - 29 Over-pressure line of the spring safety valve "Chamber"***)
 - 30 Tap for manual emptying of the air gap container
 - 31 Connection for decalcifying the vacuum pump (for service technicians only)
 - 32 Network cable connection (RJ45)
- *) Applies to Cliniclave 45 MD.
- **) Pos. 28 and 29 are reversed with the Cliniclave 45 D.

Symbols on the device

Type plate



Manufacturer of the product



Date of manufacture of the product



Label as medical device



Article number of the product



Serial number of the product



Observe user manual or electronic user manual



Do not dispose of product in household waste



CE marking



Identification number of the notified body responsible for conformity assessment according to Pressure Equipment Directive 2014/68/EU



Identification number of the notified body responsible for conformity assessment according to Regulation (EU) 2017/745 on medical devices



Volume of the sterilization chamber



Working overpressure in sterilization chamber



Operating temperature in sterilization chamber



Electrical connection of the product: Alternating current (AC)

Other symbols



This symbol indicates that the device is live. Contact with live parts result in serious injury and danger to life.



This symbol indicates areas are subject to the influence of high temperatures. Contact with these areas can result in burns. This symbol also indicates the possibility of steam egress. Sign in the door area: "Attention hot surfaces".



This symbol draws attention to an increased danger of crushing resulting from the improper closure of the door. Comply with the instructions outlined in the corresponding chapter.

Symbols on the power switch



Switching on device



Switching off device

Colour touch display



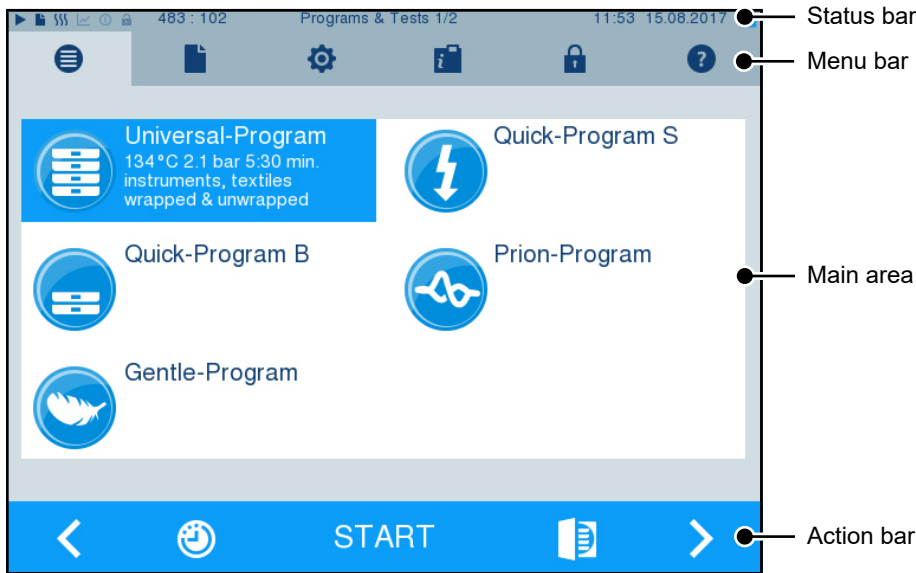

The operating panel consists of a colour 5.7 inch touch display.









The steam sterilizer can be operated from both the loading and the removal side via the colour touch display. Program selection and start are always performed via the loading side. Depending on the loading situation, one side can be temporarily locked. Comply with the corresponding message on the display.



Symbols in the status bar		Description
	Program/tests	Indicates whether a program/test is running
	Immediate output	Indicates whether immediate output is activated/deactivated
	Additional drying	Indicates whether additional drying is activated/deactivated
	Graphic logs	Indicates whether the graphic log recording is activated/deactivated
	Energy-saving mode	Indicates whether the steam sterilizer is currently in energy-saving mode
	Service area	Indicates whether a service technician is logged-in to the service area
	CF card status	Indicates whether a CF card has been inserted and whether a reading or writing action is in process

Symbols in the menu bar		Description
	Program/tests	Lists all reprocessing programs and tests, e.g. Vacuum test, Bowie & Dick test.
	Log output	Here you can display the entire log list or the list of logs from a restricted time (e.g. day, month). You can also delete specific log types and logs.

Symbols in the menu bar		Description
	Settings	Here you can perform various settings (e.g. date and time, brightness). It also enables one-time setting of the standard logging settings regarding log output.
	Info/status window	Displays information regarding the software version and device data, e.g. total number of batches, maintenance counter, log settings, log memory, and further technical values.
	Service area	Only for service technicians.
	Help menu	Depending on the window selected and the operating situation, gives information regarding operation or the function of the window currently selected.

Symbols in the action bar		Description
	Door open	Opens the door of the steam sterilizer
	Back	Navigates to the previous window
	Forwards	Navigates to the next window
	Cancel/return without saving	Navigates to the superordinate menu, leaves the window without saving
	Zoom (+)	Displays further details such as further values after a completed program
	Start time pre-selection	Navigates to the menu Start time pre-selection
	Delete	Deletes logs from the internal log memory/deletes the log printer or label printer stored as standard
	Search	Search for label printer / log printer
	Skip	Navigates to the next window without entry of the required data

LED status bar

The status bar on the lowest edge of the display indicates different situations with various colours.

Colour	Description
Blue	Standby, program running, drying has not yet begun
Green	Drying running, program completed successfully
Yellow	Warning message, software update is running
Red	Malfunction message, program not completed successfully

Mounts for the load

PLEASE NOTE

We do not recommend using the mounts in the rear half of the Cliniclave 45 MD with the Basic slide rail. In such a case, please use the Comfort loading system.

Mount for 2 instrument baskets or 4 large trays

The Cliniclave 45 D can accommodate a single mount; the Cliniclave 45 MD accommodates up to two mounts of this type.

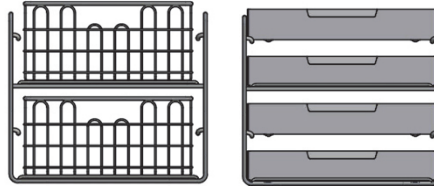
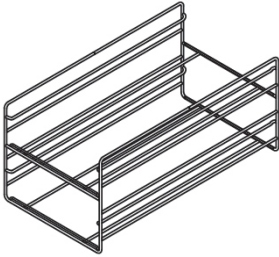

for 2 instrument baskets or 4 large trays

5 First steps

Setup and installation

PLEASE NOTE

For setup and installation, observe the information in the technical manual. This contains all building-side requirements.

Comply with the following for safe handling:

- Check the device after unpacking for any damage suffered during transport.
- The device should only be setup, installed and commissioned by MELAG authorised persons.
- The connections for electrical provision and water supply and discharge must be setup by trained personnel.
- Using the optional electronic leak detector (water stop) minimises the risk of water damage.
- The device is not suitable for operation in explosive atmospheres.
- Install and operate the device in a frost-free environment.
- The device is conceived for use outside the patient area. The device should be located a minimum of 1.5 m radius away from the treatment area.
- The documentation media (computer, CF card reader etc.) must be placed in such a way that they cannot come into contact with liquids.

Record of installation

As evidence of proper setup, installation and initial commissioning as well as your warranty claim, the record of installation must be completed by an authorised specialist and a copy sent to MELAG.

Feed water supply

Use of high quality feed water

▶Distilled or ▶demineralised/deionised water is required for the steam sterilisation. ▶EN 285 recommends compliance with the guide values in Annex B, Table B.1 when using feed water, see Technical manual. For normal operation of the steam sterilizer, the value of 5 µS/cm recommended in Table B.1 of EN 285 should not be exceeded.

The feed water from the MELAdem 56/MELAdem 56 M reverse osmosis unit fulfils the requirements placed on feed water.

Because of the design of the steam generator and the process used for steam generation with integrated degassing, higher conductivity values are permissible for short periods in exceptional cases. This also keeps the practice running:

- Regularly check the current conductivity of the feed water.
- Plan for a prompt replacement of the mixed bed resin cartridge if the conductivity is above 5 µS/cm.
- The display issues a warning message once conductivity has reached 20 µS/cm. Replace the mixed bed resin cartridge, or check the system.

The feed water supply in the steam sterilizer

The feed water is preferably supplied via the MELAdem 56 or MELAdem 56 M water treatment units. These water treatment units produce the optimum feed water quality for the steam sterilizer. The water treatment units are supplied via the air gap integrated in the steam sterilizer. This prevents the water from flowing back into the drinking water supply and corresponds fully to the requirements of ▶EN 1717 (fluid category 5). For more information, see the user manual of the water treatment unit.

PLEASE NOTE

If you would like to use a water treatment unit from another manufacturer, please contact MELAG first and observe the installation instructions.

Switch on the device

The following must be fulfilled or present:

- ✓ The device is connected to the power supply.
- ✓ The feed water supply is secure.

1. Switch on the device at the power switch.

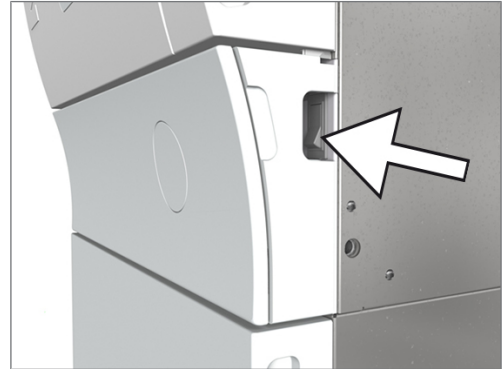

2. When the welcome screen appears, press CONTINUE. The display changes to the main menu.

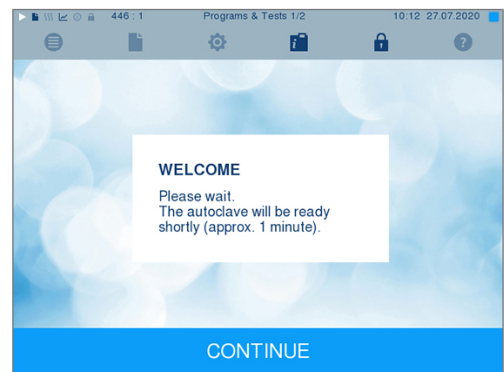

The feed water level is checked and pre-heated immediately after activation.

After device activation, a ▶pre-heating time of approx. 20 min is required depending on the device type. This time is required for the pre-heating of the double jacket steam generator.

Opening and closing the door

The steam sterilizer is fitted with a motor-driven automatic door locking mechanism with a threaded spindle. Entry on the display is only possible when the door is closed.

⚠ CAUTION

Warning of injury

Swinging the door can cause crushing or bruising.

- Always hold the door on the lateral grips intended for this purpose.

ℹ PLEASE NOTE

Depending on the operating system, only one side of the steam sterilizer can be opened at any one time in order to separate the impure and the pure sides.

Opening the door

The door is opened by pressing on the door symbol  on the display.

When opening the door, comply with the following instructions, so as to ensure faultless operation of the door locking mechanism.

- Never use force to open the door.
- Do not pull vigorously at the door to open it. The door unlocks automatically.

PLEASE NOTE

The door is to be left open only whilst loading and unloading the steam sterilizer. Keeping the door closed saves energy.

Closing the door

To close the door, press it firmly inwards until the automatic door lock engages. After the door has been closed, the display returns to the program menu. The door is locked pressure-tight upon program start.

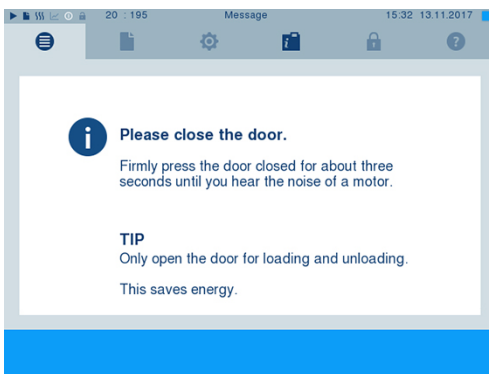

When closing the door, comply with the following instructions to guarantee faultless operation of the door locking mechanism:

- Make sure that the brakes on the casters have been engaged.
- Do not slam the door.
- Keep pressing the door closed until the door lock engages.

Manual door emergency-opening

CAUTION

Warning of scalding

On opening the door, steam and hot water can escape from the sterilization chamber. e.g. if it is necessary to open the door immediately after the end of a program. This could result in scalding.

- Should steam be issued from the rear of the device after its deactivation, wait until the procedure has finished. Wait a further 5 min before opening the door.
- Stand to one side of the door and maintain sufficient distance.
- Allow the sterilization chamber to cool before removing the load.

CAUTION

Warning of scalding

On opening the door, steam and hot water can escape from the sterilization chamber. e.g. if it is necessary to open the door immediately after the end of a program. This could result in scalding.

- If steam is emitted from underneath the device or from the left-hand side after deactivation, wait until the procedure has ended. Wait a further 5 min before opening the door.
- Stand to one side of the door and maintain sufficient distance.
- Allow the sterilization chamber to cool before removing the load.

PLEASE NOTE

The door should always be opened on the loading side. Open on the removal side only after a successful program run.

In emergency situations e.g. power outage, the door can be opened in the following fashion:

1. If the steam sterilizer is still switched on, switch it off at the power switch.
2. Remove the cover cap in order to enable emergency door-opening by pressing the cover cap that is on the side of the door towards the centre, inwards (i.e. on a door closing to the right on the right-hand side; on a door closing to the left on the left-hand side of the cover cap).
3. Lever the cover cap out of the opening at an angle. Observe the retaining brackets whilst doing so.
4. Remove the 10 mm Allen key included in the scope of delivery from its bracket in the floor unit. Insert it in the door-lock nut behind the opening.

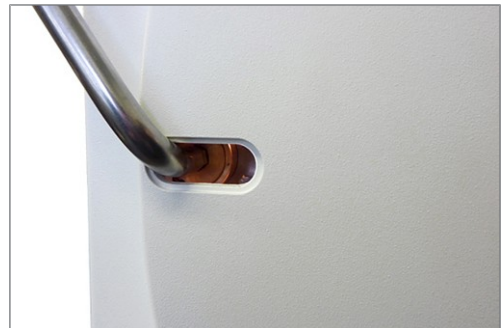
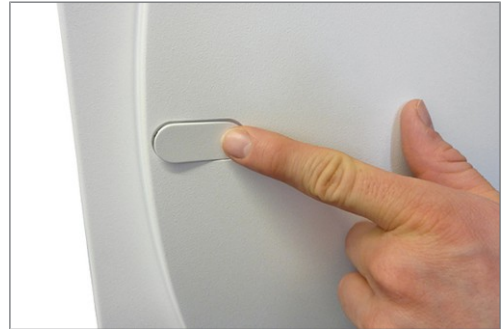

5. Turn the Allen key in an anti-clockwise direction to open the door.
6. Remove the Allen key after opening and return the cover cap.

6 Loading the steam sterilizer

Preparing the load

Always clean and disinfect properly before sterilization. Only in this way is it possible to guarantee the subsequent sterilization of the [▶load](#). The materials used, cleaning agents and reprocessing procedure are of decisive significance.

Comply with the following for safe handling:

- Only ever use packaging material and systems which have been cleared by their manufacturer for steam sterilization.
- Only use original MELAG articles or third-party articles approved by MELAG. No warranty can be provided for non-approved third-party articles, even if validation has been successfully carried out.

Reprocessing textiles

The incorrect reprocessing of textiles, e.g. a textile package can prevent steam penetration or produce poor drying results. This may result in the textiles **not** being sterile.

Comply with the following points when [▶reprocessing](#) textiles and placing the textiles in sterile containers:

- Comply with both the reprocessing instructions of the textile manufacturer the relevant standards, guidelines and directives (in Germany e.g. of the [▶RKI](#) and [▶DGSV](#)).
- Arrange the folds in the textiles parallel to each other.
- Stack textiles vertically wherever possible and not too closely together in the sterile container. This enables the development of flow channels.
- If textile packages do not remain together, wrap the textiles in sterilization paper.
- Only ever sterilize dry textiles.
- The textiles may not be permitted to come into direct contact with the sterilization chamber; otherwise they will become saturated with [▶condensate](#).

Reprocessing instruments

Unwrapped sterile material loses its sterility on contact with ambient air. If you intend to store your instruments sterily, wrap them in suitable packaging before sterilization.

When [▶reprocessing](#) used and brand-new instruments, comply with the following:

- Always observe both the instrument manufacturer's reprocessing instructions and the relevant standards, guidelines and directives (in Germany, for example, from [▶RKI](#), [▶DGSV](#) and [▶DGUV Regulation 1](#)).
- Clean the instruments exceptionally thoroughly e.g. using an ultrasonic device or washer-disinfector.
- Rinse the instruments after washing and disinfecting, where possible with demineralised or distilled water, and then dry the instruments thoroughly with a clean, non-fuzzing cloth.
- Re-dry the spray, air and water channels using medical compressed air.
- Use only those care agents suitable for steam sterilization. Consult the manufacturer of the care agents. Do not use any water repellent agents or oils impermeable to steam. MELAG recommends the use of MELAG Care Oil Spray.
- When using ultrasound devices, care equipment for handpieces and washer-disinfectors, comply with the manufacturer's reprocessing instructions.
- Remove any residual disinfection and cleaning fluids to avoid corrosion. Otherwise, this could result in increased maintenance requirements and a restriction of the device function.

Loading the steam sterilizer

Effective sterilization and good drying is only possible if the steam sterilizer has been loaded correctly.

Ensure the following during loading:

- Insert trays or sterile containers in the sterilization chamber only with their appropriate mount.

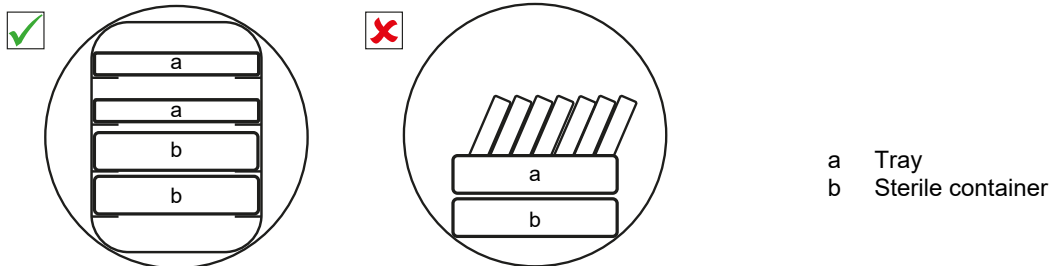

- Wherever possible, ensure the separate sterilization of textiles and instruments in separate sterile containers or sterilization packages. This leads to better drying results.
- The use of paper tray inserts can result in poor drying results.
- Use perforated trays such as those from MELAG. Only in this way can **condensate** drain off. Non-perforated bases or half-shells for holding the **load** lead to poor drying results.

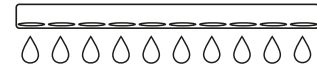

Packaging

Only ever use packaging materials and systems (**sterile barrier systems**) which fulfil the standard **EN ISO 11607-1**. The correct use of suitable packaging is important in achieving successful sterilization results. You can use re-usable rigid packaging systems or soft packaging such as transparent sterilization package, paper pouches, sterilization paper, textiles or fleece.

Closed sterile containers

Please comply with the following when using closed sterile containers:

- Use aluminium sterile containers. Aluminium retains and conducts heat and thus accelerates drying.
- Closed sterile containers must be either perforated or have a valve on at least one side. MELAG sterile containers, e.g. MELAstore Box, fulfil the requirements for successful sterilization and drying.
- Wherever possible, ensure that sterile containers are only stacked on top of those of identical size, so that the condensate can run down their sides.
- Ensure that the perforations are not covered when stacking the sterile containers so that the condensate can drain off.

PLEASE NOTE: For very heavy loads (e.g. orthopaedic instruments) that can produce large quantities of condensate, MELAG recommends the use of containers with condensate drains, e.g. from Wagner.

Soft sterilization packaging

Soft sterilization packages can be used in both sterile containers and on trays. Please comply with the following when using soft sterilization packages e.g. MELAfol:

- Arrange transparent sterilization packages on edge and close together. If this is not possible, place them with the paper side facing downwards.
- Do not place multiple soft sterilization packages flat on top of each other on a tray or in a container.
- When loading the steam sterilizer, make sure that either the film or paper sides of different pouches are facing each other.
- If the seal seam tears during sterilization, this could be caused by the choice of undersized packaging. Pack the instruments with larger packaging and perform sterilization again.
- Should the seal seam tear during sterilization despite sufficient bag size, adjust the sealing temperature on the sealing device or make a double seam.

Multiple wrapping

The device uses a fractionated vacuum procedure. This permits the use of [multiple wrapping](#).

Mixed loads

Please observe the following when sterilizing [mixed loads](#):

- Always place textiles at the top
- Sterile containers at the bottom
- Place unwrapped instruments at the bottom
- Place the heaviest loads at the bottom
- Transparent sterilization packages and paper packages on the top. Exception: At the bottom in combination with textiles

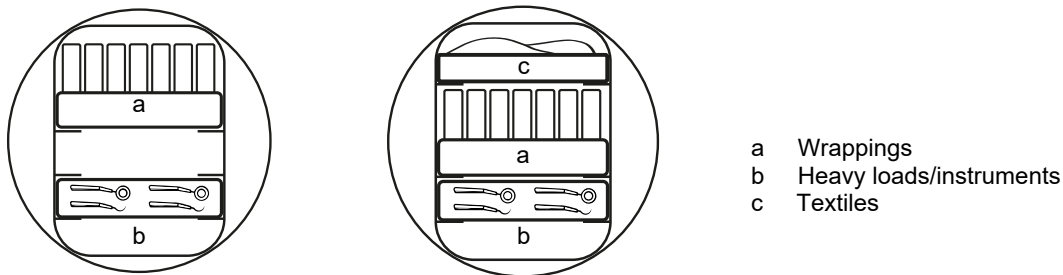

Load quantities and versions

Max. weight per component

Load	Instruments	Textiles
Max. weight per component	2 kg	2 kg

Maximum load quantities for instruments and textiles

The total weight is the sum of the mass of the load to be sterilized, the packaging materials, the containers and the mount.

For further information, see [Selecting the program](#) [▶ page 25].

Loading variants per [sterilization module \(StM\)](#)

Nature of the mounts ^{*)}	Loading version
Mount for 2 instrument baskets or 4 large trays	max. 4 large trays max. 2x ½ StM sterilization container max. 2x ½ StM instrument baskets
Mount for 8 small trays ^{**)}	max. 24 dental trays (8 per mount)
Mount for dental containers ^{**)}	max. 15 dental containers or MELAstore Box (5 per mount)
Without mount	max. 1 sterilization container (1 StM)

^{*)} For mounts, trays, etc. from MELAG, see [Mounts for the load](#) [▶ page 15]

^{**)} MELAG does not recommend using this mount in the rear half of Cliniclave 45 MD with the loading system Basic. In this case, use the loading system Comfort.

Loading system Comfort

MELAG provides a loading system Comfort consisting of a loading trolley, slide rail, batch slider and loading hook. This enables effortless and ergonomic loading and unloading of the steam sterilizer. For information on setting and using the loading trolley see User manual Accessories for large steam sterilizers.

Refer to the user manual of the sterilization containers used. Never exceed the max. permissible load quantity and weight specified by the manufacturer.



7 Sterilization

Important information regarding routine operation

Daily routine checks

- Check the sterilization chamber and seal for proper condition, see [Maintenance](#) [▶ page 62].
- Check the operational readiness of the recording equipment, see [Logging](#) [▶ page 36].
- Perform a Bowie & Dick test (steam penetration test), see [Function checks](#) [▶ page 43].

When using the MELAdem 56/56 M water treatment unit

- Perform regular checks of the pressure on the pressure tank manometer before first program start. With daily operation, the pressure tank is still sufficiently full from the previous day.
- The blue pointer shows the current pressure of the water treatment unit.
- The red pointer is used to check the maximum pressure of the water treatment unit.

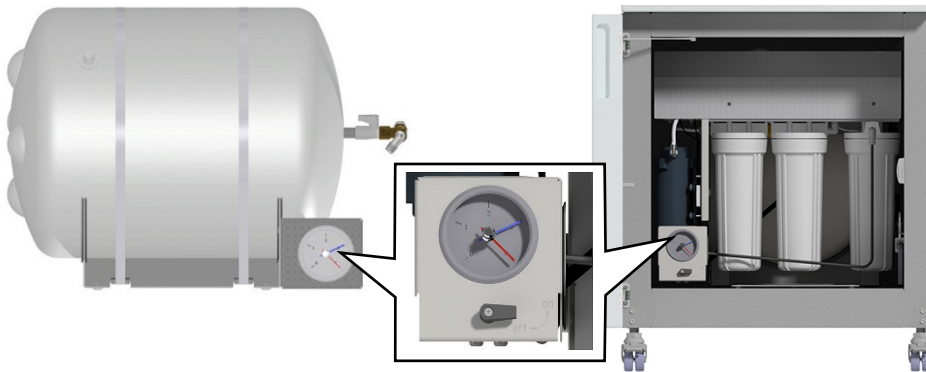

left: pressure tank MELAdem 56 | right: MELAdem 56 M

Pressure in the pressure tank (blue indicator)	Description	Measure
3-4 bar	Recommended operating pressure	--
< 2.5 bar	Little feed water in the pressure tank	Leave the steam sterilizer switched on so that the water treatment unit can produce feed water.
< 1 bar	No or insufficient feed water in the pressure tank	Leave the steam sterilizer switched on so that the water treatment unit can produce feed water. A warning or malfunction message will be displayed.

Further routine checks

EN ISO 17665-1 and ▶[DIN 58946-7](#) prescribe the following fundamental procedures for routine operation:

When is it necessary to make checks?	How should the checks be made?
Before starting routine operation	Installation qualification (IQ); Operational qualification (OQ); Performance qualification (PQ)
Monthly	Vacuum test
After 4000 cycles but after 12 months at the latest	Maintenance

When is it necessary to make checks?	How should the checks be made?
After changes to the steam sterilizer and its supply	Operational qualification (OQ)
After changes to the configuration	Renewed performance qualification (PQ) for a particular reason
At fixed intervals after 12-24 months*)	Renewed performance qualification (PQ)
*) In accordance with the stated standards and according to the assessment of the person performing the validation.	

Selecting the program

Select the reprocessing program according to whether and how the ▶load is wrapped. It is also necessary to take into account the temperature resistance of the load. All sterilization and additional programs are displayed in the **Programs & Tests** menu. The following tables show you which program you use for which load and which additional programs are also available to you.

The stated operating time does not include drying and depends on the load and the setup conditions, e.g. mains voltage and air pressure. The device requires an additional one-off heating-up time to pre-heat the double jacket steam generator after activation. For normal operation, this amounts to approx. 20 min.

When taking into account the specified load quantity, the program-specific drying times (time-controlled drying) ensure excellent drying of the sterile material. [Additional drying](#) [▶ page 55] can be activated for particularly difficult drying tasks. [Intelligent drying](#) [▶ page 56] is activated in the as-delivered state.

Drying for 35 kg or 70 kg loads was tested with dental containers and MELAstore Box. Drying of other large weights (20-40 kg/40-80 kg wrapped) or other load configurations must be checked on site for each case. Activate additional drying if necessary.

Universal-Program

	134 °C 2.1 bar 5:30 min	Especially suitable for	<ul style="list-style-type: none"> • Transmission instruments • Products with narrow lumen • Simple hollow bodies
---	-------------------------------	-------------------------	--

Load type	Load quantity		Operating time		Drying	
	45 D	45 MD	45 D	45 MD	Time-controlled	Intelligent
Partial load: • unwrapped • single wrapped • multiple wrapping	15 kg	30 kg	approx. 21 min	approx. 28 min	20 min	4-30 min
Full load: • unwrapped • single wrapped • multiple wrapping	40 kg 35 kg 35 kg	80 kg 70 kg 70 kg	approx. 40 min	approx. 50 min	20 min	4-30 min
Textiles: • single wrapped	7 kg	14 kg	approx. 28 min	approx. 36 min	20 min	4-30 min

Quick-Program B

	134 °C 2.1 bar 5:30 min	Especially suitable for	<ul style="list-style-type: none"> • Transmission instruments • Products with narrow lumen • Simple hollow bodies
---	-------------------------------	-------------------------	--

Load type	Load quantity		Operating time		Drying	
	45 D	45 MD	45 D	45 MD	Time-controlled	Intelligent
Partial load: • unwrapped • single wrapped • multiple wrapping	15 kg	30 kg	approx. 21 min	approx. 28 min	approx. 10 min	4-30 min
No textiles	--	--	--	--	--	--

Quick-Program S

	134 °C 2.1 bar 3:30 min	Especially suitable for	<ul style="list-style-type: none"> • Simple solid instruments • Simple hollow bodies
---	-------------------------------	-------------------------	--

Load type	Load quantity		Operating time		Drying	
	45 D	45 MD	45 D	45 MD	Time-controlled	Intelligent
Partial load: • unwrapped	15 kg	30 kg	approx. 17 min	approx. 22 min	approx. 6 min	4-30 min
No textiles	--	--	--	--	--	--

Gentle-Program

	121 °C 1.1 bar 20:30 min	Especially suitable for	<ul style="list-style-type: none"> • Thermo-unstable equipment (e.g. plastic, rubber, textiles) • Products with narrow lumen • Simple hollow bodies
---	--------------------------------	-------------------------	--

Load type	Load quantity		Operating time		Drying	
	45 D	45 MD	45 D	45 MD	Time-controlled	Intelligent
Partial load: • single wrapped • multiple wrapping	15 kg	30 kg	approx. 36 min	approx. 45 min	20 min	4-30 min
Textiles: • single wrapped	7 kg	14 kg	approx. 45 min	approx. 53 min	20 min	4-30 min

Prion-Program

	134 °C 2.1 bar 20:30 min	Especially suitable for	<ul style="list-style-type: none"> • Instruments with more stringent sterilization requirements^{*)} • Transmission instruments • Products with narrow lumen • Simple hollow bodies
---	--------------------------------	-------------------------	---





^{*)} The Prion-Program provides an extended plateau period at 134 °C to help reduce the risk of prion transmission - particularly when users comply with the applicable national or institutional requirements for handling potential prion contamination. The Prion-Program does not ensure complete inactivation of prions and does not claim prion inactivation.

Use the Prion-Program only as part of a validated overall reprocessing procedure, including thorough pre-cleaning and, where required, chemical prion decontamination in accordance with the applicable guidelines.

Use the Prion-Program only in accordance with the national or international guidelines applicable to you, e.g. "Hygiene requirements for the reprocessing of medical devices. Recommendation of the Commission for Hospital Hygiene and Infection Prevention (▶KRINKO) at the Robert Koch Institute (▶RKI) and the Federal Institute for Drugs and Medical Devices (▶BfArM)" (2012, PMID: 23011095; German national guideline).

Always discard reusable medical instruments that have been in contact with high- or medium-risk tissue from patients with suspected or confirmed Creutzfeldt-Jakob disease - whether owned or borrowed. Prion proteins may be resistant to conventional sterilization processes!

Load type	Load quantity		Operating time		Drying	
	45 D	45 MD	45 D	45 MD	Time-controlled	Intelligent
Partial load: • unwrapped • single wrapped • multiple wrapping	15 kg	30 kg	approx. 36 min	approx. 43 min	20 min	4-50 min
Full load: • unwrapped • single wrapped • multiple wrapping	40 kg 35 kg 35 kg	80 kg 70 kg 70 kg	approx. 55 min	approx. 65 min	20 min	4-50 min
Textiles: • single wrapped	7 kg	14 kg	approx. 43 min	approx. 51 min	20 min	4-50 min

Additional programs		Use/function
Vacuum test		For measuring the leakage rate, test with a dry and cold device (test without load)
Bowie & Dick test		Steam penetration test with special test package (available from specialist stockists)
Conductivity meas.		For manual measurement of the ▶feed water quality (conductivity)
Drain		For draining and pressure release of the ▶steam generator, e.g. for service, maintenance or before transport

Additional program options

Additional drying

The program-specific drying times ensure excellent drying of the sterile items. For difficult drying tasks, you can activate the additional drying – also subsequently during a running program, see [Additional drying](#) [▶ page 55].

Start time pre-selection

NOTICE

Warning of material damage to the device or the equipment

Unsupervised operation can result in material damage to the device and the equipment. Unattended operation is performed at the operator’s risk. In such a case, MELAG does not accept any liability.

- Never operate the device unattended.

This function enables you to select any program and start it at a time of your choice. The start time pre-selection is only active for the unique time and program selection. This means that after completion of the program, the pre-selected start time expires. You can switch off the steam sterilizer during the start time pre-selection. However, the steam sterilizer must be switched on before the timer runs out.

The start time pre-selection can only be started from the loading side. It can be aborted on both the loading and the removal side.

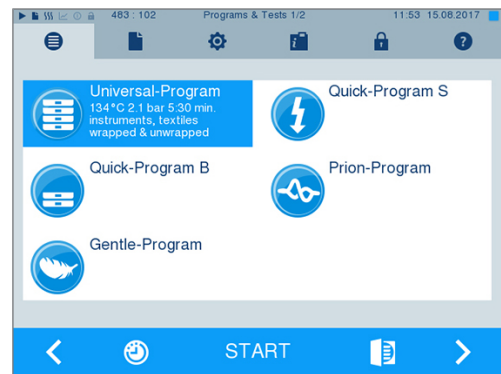

Note that this function is not possible for the Quick-Program S due to the confirmation prompt. To set a program start to a particular time, proceed as follows:

1. After selecting the program, press the  symbol in the action bar. The display switches to the settings window.

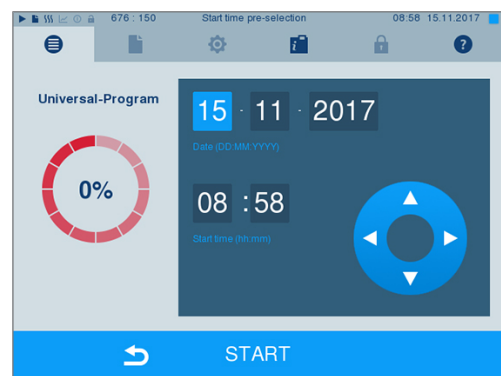

2. For example, to change the time, directly tap the parameter **Hour** or **Minutes**. The selected field is highlighted light blue.



3. Change the hour, for example, by pressing the  or  buttons.

4. Then press START. The display remains in the start time pre-selection window.

➔ After the start of the start time pre-selection no other menu apart from the **Info & Status** menu can be selected.

Automatic shutdown

Activating the automatic shutdown function enables the automatic deactivation of the steam sterilizer at the end of a program, e.g. after the last batch at the end of the day. Batch approval can be performed by reactivating the steam sterilizer as usual. Proceed as follows to activate automatic shutdown for the next program run:

1. Select the desired program.
2. Press START.
3. Select the **Settings** menu. The display switches to the following window.
4. To activate automatic shutdown, set a checkmark and confirm with **SAVE**.

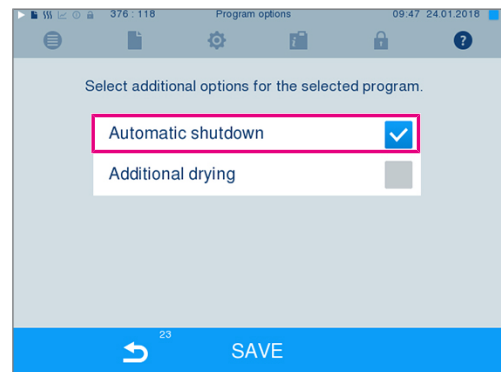
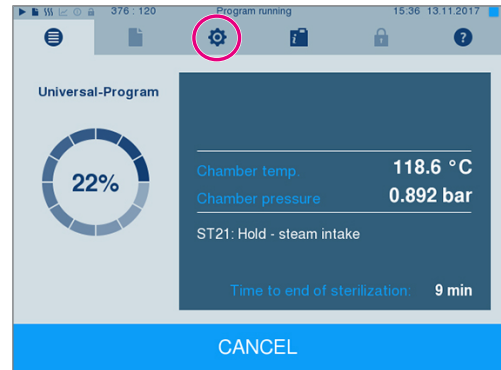

Starting the program

A program can only ever be started on the loading side. A program is displayed as marked after it has been selected.

1. To start a program, press the **START** button.

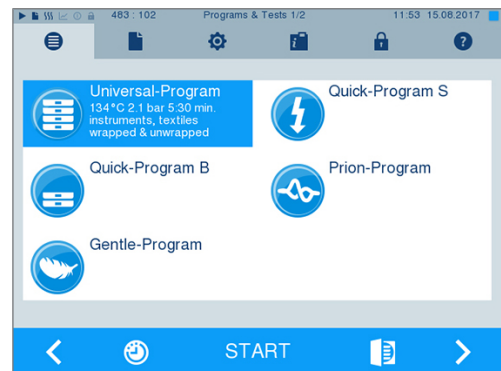

↳ The door closes pressure-tight and the device controls the amount of **feed water** and its **conductivity**.

2. With activated user authentication:

Enter the user PIN or, if possible, press the  button to skip input, see [User administration](#) [▶ page 51].

PLEASE NOTE: Use the function “Skip user authentication” only in an emergency.

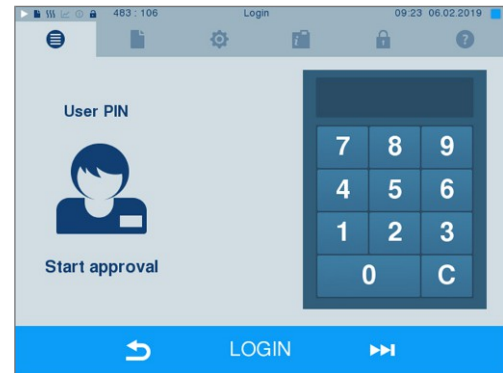

PLEASE NOTE

When starting the Quick-Program S, a warning and an acoustic signal indicate that this program is suitable only for the sterilization of unwrapped instruments. If the load contains unwrapped instruments only, confirm with YES to start the program.

Program run

A program runs in three main phases: the de-aeration and heating up phase, the sterilization phase and the drying phase. After program start, you can follow the program run on the display. It shows the chamber temperature and pressure as well as the time until the end of sterilization / drying.

De-aeration and heating up phase

During this phase, the steam will be injected and removed from the sterilization chamber (conditioning) to generate over-pressure and remove residual air. Then, during fractionation, the mixture of air and steam is evacuated from the sterilization chamber and steam is injected. This reduces the level of residual air in the sterilization chamber to a minimum. At the same time, the requirements for pressure and temperature are created for sterilization.

Sterilization phase

In the sterilization phase, pressure and temperature are held in the area required for sterilization.

The display indicates whether the sterilization phase has been completed successfully. The coloured ring and the LED status bar switches from blue to green as soon as the drying phase has been introduced.

The sterilization phase is unsuccessful if the user or the system (responding to a malfunction) aborts the program run. A system abort returns the steam sterilizer to a pressureless state. This explains why a system abort takes longer than an abort by the user.

Drying phase

The steam sterilizer provides excellent drying of the ▶load. Depending on the setting, drying is performed either via the time-controlled drying or the pre-set intelligent drying, see [Intelligent drying](#) [▶ page 56]. If difficult-to-dry items require better drying, you can undertake the following steps to improve drying:

- Load the steam sterilizer properly. Stand e.g. the transparent and paper sterilization packaging upright, see [Loading the steam sterilizer](#) [▶ page 21]. Use the optional package holder if necessary.
- Time-controlled drying: Activate function **Additional drying** in order to extend the drying time by 50%.
- Intelligent drying: Activate function **Additional drying** in order to restrict the criteria for ending the drying phase.

Monitoring the program run on the computer

You can follow the current progress of a reprocessing program on every computer in the practice network.

The following must be fulfilled or present:

- ✓ An IP address is assigned for the steam sterilizer.
 - ✓ The steam sterilizer is integrated into the practice network.
1. Open a web browser (we recommend Mozilla Firefox or Internet Explorer/Microsoft Edge) and enter the IP address of the steam sterilizer in the address bar of the web browser e.g. 192.168.57.41.
 2. Confirm with [ENTER]. Now you can display the program run or information about your steam sterilizer, e.g. serial number, device software version and selected values.

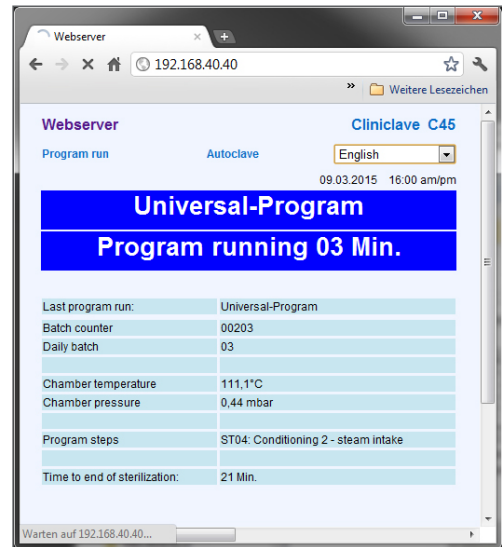
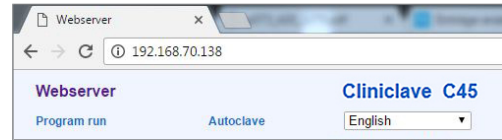

Manual program abort

You can abort a current program in all phases. If you abort the program before the end of the sterilization phase, the load is **not** sterile.

⚠ WARNING

Warning of burns

Hot steam can be released from the emergency release valve under the floor unit on the loading side after a program abort effected with the power switch. This could result in burns.

- Never cancel a program by switching off at the mains.

Comply with the following for safe handling:

- Please observe that depending on the time of the program abort, opening the door following a program abort can lead to hot steam leaving the sterilization chamber.

Program abort before the start of drying

⚠ WARNING

Warning of contamination

If a program is terminated before drying starts, the load is **not** sterile.

- Re-wrap the load if necessary.
- Repeat the sterilization of the load.

Should you abort a program before drying starts the sterile material may only be removed on the unclean side (the loading side). The display indicates that the program was NOT completed successfully; this is also recorded on the log.

Should you still wish to do so, proceed as follows to abort the program before drying:

1. Press CANCEL on the action bar.

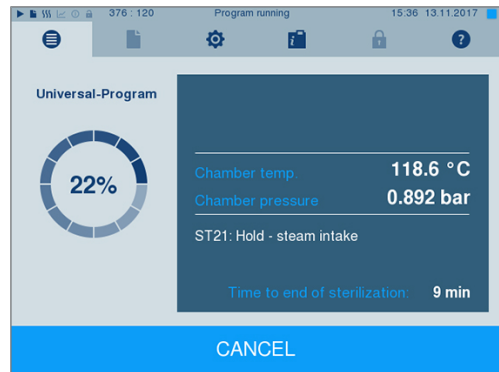

2. Confirm the security query with YES.

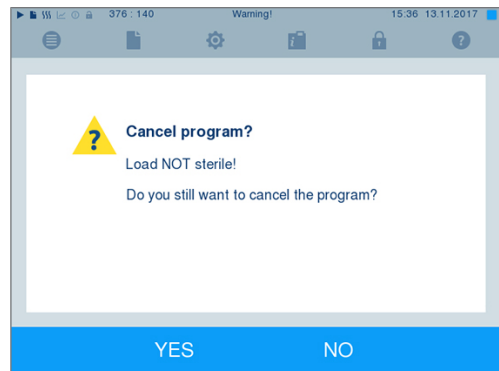

3. After a short time, you can open the door by pressing .

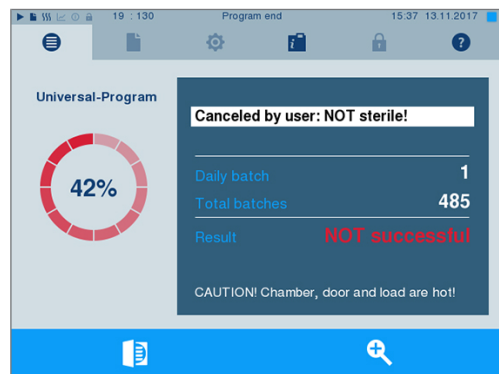

- The display shows a warning.
- Sterilization is marked on the log as **NOT successful**.

Program abort after the start of drying

CAUTION

Warning of recontamination

If the drying phase is terminated prematurely, it is possible that the maximum residual moisture (textiles < 1 %, metal < 0.2 %) required by the ▶EN 285 standard cannot be met. This impairs the storage stability of the sterile material.

- Only ever perform a premature drying abort in exceptional cases to effect immediate renewed availability of the device.
- Check the sterile material after a program abort for residual moisture. Never store sterile material when it is still damp, as the residual moisture can result in recontamination of the sterilized material.

Should you abort a program after drying has started, the sterilization is having been completed successfully. The steam sterilizer will not issue a malfunction message. You should expect insufficient drying, especially in the case of wrapped ▶sterile material and a full load. Sterile storage requires sufficient drying. To ensure this, allow programs with wrapped sterile material to continue to the end of the drying phase as far as possible. Unwrapped instruments sterilized in a Quick-Program dry after being removed from their own warmth.

Proceed as follows to abort the program during drying:

1. Press STOP on the action bar.

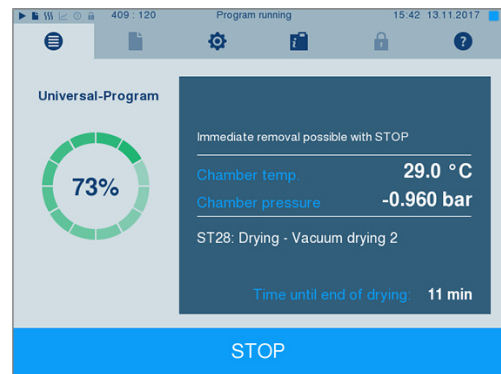

2. Confirm the security query with YES.

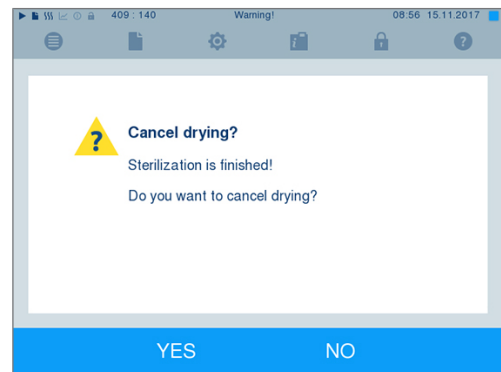

3. After a short time, you can open the door by pressing .

Program end

When the program has ended successfully, the corresponding message will be issued on the display. Before opening the door, you can view further values on the display from the program which has just completed, e.g. the plateau time

or ▶conductivity etc. by pressing the zoom symbol .

▶ Press the door symbol  to unlock the door.

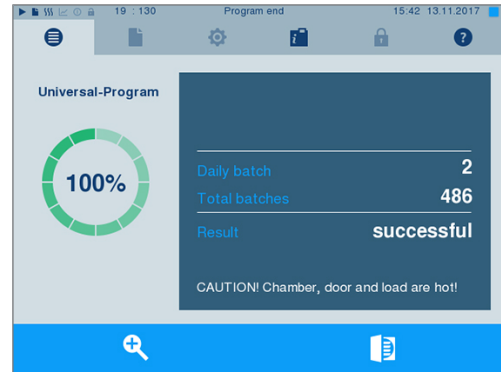

If automatic logging after program end is activated (= Immediate output) in the **Settings > Logging** menu, the log of the completed program will be outputted to the activated output medium after opening the door.

The approval process

In accordance with ▶RKI “Hygiene requirements for the reprocessing of medical devices”, instrument preparation ends with the documented approval for storage and application of the ▶sterile material. The approval process consists of ▶batch indication and batch approval and must be performed by authorised and expert personnel. This is ensured by the activated user authentication. To do this, enter the user PIN, see **Settings** [▶ page 45].

PLEASE NOTE

Skipping user authentication means that the batch is not approved.

- Use the function “Skip user authentication” only in an emergency.

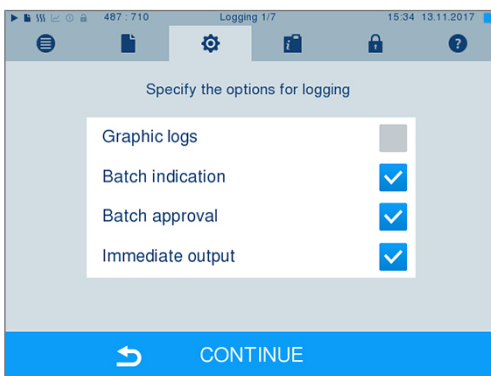

Batch indication includes checking the indicators carried in the reprocessing program (e.g. MELAcontrol Helix or MELAcontrol Pro). Approval of the indicator strip is possible only if it changes colour entirely.

Batch approval comprises the checking of the process parameters using the sterilization results on the steam sterilizer and the sterilization log as well as checking of the individual packaging for damage and residual moisture. The sterilization log records the approval of the ▶batch and any indicators. Depending on the setting in the user administration, approval for the ▶sterile material requires the user PIN of the person who provides approval for the batch and the indicators.

Removing the sterile material

⚠ WARNING

Warning of contamination

If packaging is damaged or has burst after sterilization, the instruments are unsterile.

- Re-wrap the load.
- Carry out the sterilization again.

⚠ CAUTION

Warning of burns

Touching hot metal surfaces can cause burns.

- Allow the device to cool sufficiently before opening.
- Never touch the load, the sterilization chamber or the door with unprotected hands.

⚠ CAUTION

Warning of burns

If the mount slip out it can cause burns.

- Only remove the trays and instrument baskets one at a time from the steam sterilizer.
- Do not remove the mount with trays or instrument baskets on it.

If you remove the ▶sterile material from the device directly after the end of the program, it is possible that the instruments can be partially damp. According to the red brochure of the Arbeitskreis für Instrumentenaufbereitung (▶AKI), single drops of water (no puddles) that dry off within 15 min are considered tolerable residual moisture in practice.

Comply with the following specifications when removing the sterile material:

- Remove then sterile material following completed and successful sterilization only from the removal side of the device.
- Never use force to open the door. This could damage the device or result in the emission of hot steam.
- Use suitable protective gloves to remove the trays.

Enable the loading side

The loading side is locked after a completed program until the sterile material has been removed and the loading side has been provided with approval. Only then is it possible to open the door on the loading side and re-load the steam sterilizer.

1. Close the door on the removal side.
2. To provide the loading side with approval, acknowledge the corresponding message on the display of the removal side by pressing the pushbutton **ENABLE**.

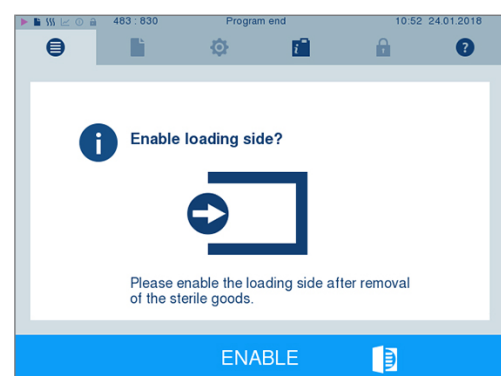

Storing sterile material

The maximum storage time is dependent on the packaging and the storage conditions. Please observe the regulatory requirements for the storage period of ▶sterile materials (in Germany e.g. ▶DIN 58953, Part 8 or the ▶DGSV guidelines) as well as the following listed criteria:

- Store the sterile material in a dust-protected environment e.g. in a closed instrument cabinet.
- Store the sterile material in an environment protected against moisture.
- Store the sterile material in an environment protected against excess temperature variations.

8 Logging

Batch documentation

The batch documentation serves as proof of the successful conclusion of the program and represents an obligatory part of quality assurance. The device internal log memory saves such data as the program type, ▶[batch](#) and process parameters of all the programs completed.

To obtain the batch documentation, you can output the internal log memory and transfer its data to various output media. This can be performed immediately at the end of every program or at a later point, such as at the end of the day.

Capacity of the internal log memory

The device is equipped with an internal log memory where all data from completed reprocessing programs are stored. The capacity is sufficient for approx. 100 logs. If the internal log memory becomes almost full and at least one log has not been output via an activated output medium, the following warning **Internal log memory is almost full** will appear. Prepare the output media specified in menu **Settings > Logging**. Print the relevant logs (menu **Log output**).

Print any unprinted logs if message **Internal log memory full** appears. By pressing **YES**, the data in the device's log memory will be automatically deleted, except for the last 40 logs.

Output media

You are able to output and archive the logs of the completed programs on the following output media:

- ▶[CF card](#)
- MELAprint 60 label printer
- MELAprint 42/44 log printer
- A computer (via the practice network)

Any combination of the output media is possible. Log output on multiply activated media is performed successively. In its delivery state, the ▶[CF card](#) is activated as the output medium for text and graphic logs from the steam sterilizer. Automatic logging (=Immediate output) is thus activated.

Detailed information regarding the activation and setting of log output is to be found in the chapter [Settings, Logging](#) [▶ page 45].

Using the CF card as an output medium

NOTICE**Warning of material damage and data loss**

When the CF card is pulled from the card slot prematurely or if it is treated improperly, data loss, damage to the CF card, the device and/or its software may occur.

- Never push the CF card in the slot with force.
- Never remove the CF card from the slot whilst it is being written or read. The square in the upper right-hand corner of the display lights up during reading and writing access.

The card slot for the CF card is located on the right-hand side of the display housing on both the loading and removal side. Logging via CF card is only possible via the slot on the loading side.

Proceed as follows in order to insert the CF card in the slot.

- ✓ The CF card is set as the output medium in the **Settings > Logging** menu.
- ✓ If immediate log output is activated, the CF card must be inserted on the loading side.

1. Insert the CF card in the card slot fully with the raised finger edge pointing rightwards and to the rear.
If the CF card is inserted correctly, a blue square will illuminate in the right upper corner of the display.



2. Check whether the CF card has been selected as the output medium.

Using the computer as an output medium

You can connect the steam sterilizer directly to a computer or integrate it in an existing (practice) network via FTP or TCP. The computer must be fitted with a RJ45 socket (LAN).

For more information on the requirements and setting the computer as the output medium, see [Settings, Logging](#) [▶ page 45].

Reading out a text log on the computer

All text logs can be opened and printed using a text editor, a word processing program or a spreadsheet program. Graphic logs can only be displayed with the MELAtace documentation software.

Each text log (e.g. .PRO, .STR, .STB) must be linked with the text editor to enable the computer to open them automatically with a text editor. For the meaning of the endings, see [Subsequent log output](#) [▶ page 39]. The following examples show how you can link the Windows 10 editor with a specific text log.

1. In Windows Explorer double click on the log file.
2. If the file ending is unfamiliar, Windows 10 will display the following message:

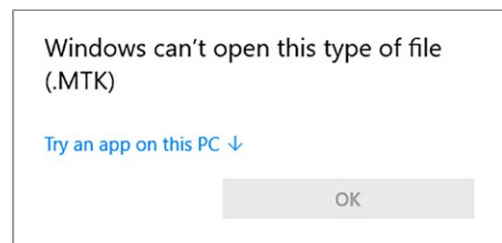

3. Select "Try an app on this PC".

4. Mark the editor and confirm with "OK".

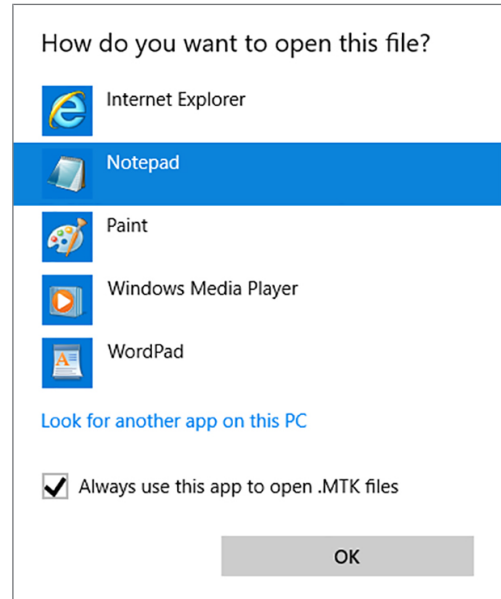

→ You can then open files with this ending via a double-click in Windows Editor.

Label printer as output medium

The use of a label printer facilitates batch traceability. By entering the following data, the sterile material can be assigned to the patient and the sterilization batch:

- Sterilization date
- Storage duration
- Batch number (daily / total batches)
- User ID (person who has authorised the sterile material for use)
- Device (type, serial number, program used)
- File name

Faultless packages containing sterile material are marked with labels after sterilization. As such, the preconditions for correct approval by the person conferred with the task of reprocessing are given. All information regarding the correct reprocessing process can be attributed to the instruments used in patient records.

PLEASE NOTE To facilitate easy assignation of a package marked with a label to a specific batch, the sterilization log file name must not be changed.

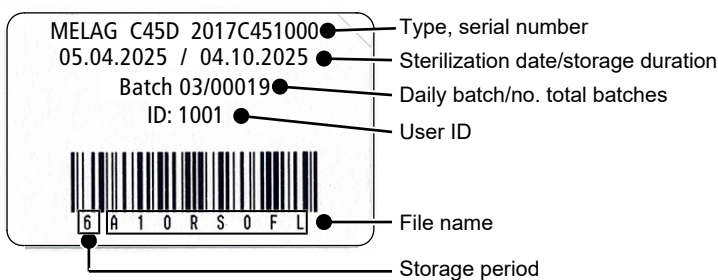

Outputting text logs automatically after program end (immediate output)

If you would like to output the associated text and graphic logs (optional) on an output medium immediately after the end of a program, use the **Immediate output** option. In its delivery state, the immediate output of the text and graphic logs via the CF card after program end is activated.

If the output medium selected for this purpose has not been connected, the logs are saved in the internal memory and a warning is issued. The steam sterilizer provides the option of outputting this log at the next possible opportunity. Graphic logs cannot be saved in the internal log memory; they are lost. For more information about the output of graphic logs, see [Outputting graphic logs \(optional\)](#) [▶ page 46].

The following points must be fulfilled for immediate output:

- The date and time have been set correctly.
- An output medium is selected and connected.
- Instant output is activated in the **Settings > Logging** menu.
- With log output to a CF card: The CF card is inserted on the loading side.

For more information on setting the instant output with the desired output media, see [Settings, Logging](#) [▶ page 45].

Subsequent log output

The **Log output** menu provides the option of outputting text logs subsequently and independently of the point of the program end. You can set the output media yourself. By default, the output media that are also selected under **Settings > Logging** are preselected provided that automatic instant output is activated.

The **Log output** menu offers various opportunities for log output. All program logs present in the memory are displayed in the **Logging list**. You can sort the list according to number, date, time, program, and outcome by pressing on the column headings. Here is an overview of all possible output media.

Name	File ending	Description
Last log	.PRO	The log of the last successful completed program is output.
Logs of the day	.PRO	The log of the last successful program of the current day is output.
Logs of the week	.PRO	Logs of all successfully completed programs of the week – Monday to Sunday – will be output.
Logs of the month	.PRO	Logs of all successfully completed programs performed in the current month will be output.
All logs	.PRO	The logs of all successfully completed programs will be output.
Last fault log	.STR	The last malfunction log is output.
Fault logs of the day	.STR	The malfunction logs of the current day are output.
etc.	...	
Legend log file	.LEG	Contains an explanation of all abbreviations contained in the log.
Status log	.STA	A summary of all important settings and system states (e.g. counter, measured values).
Fault in standby	.STB	This log type is generated following malfunctions during a time at which no program was active.
System log	.LOG	A sort of logbook listing all malfunctions and changes to the system in order of their incidence.
Delete all logs	--	Deletes all logs stored in the internal log memory. Notice: All logs that were not previously output to another output medium will be deleted.

Output a log from the log list

Proceed as follows to output a specific log from the internal memory:

1. Navigate to the **Log output** menu, and select **Logging list**.

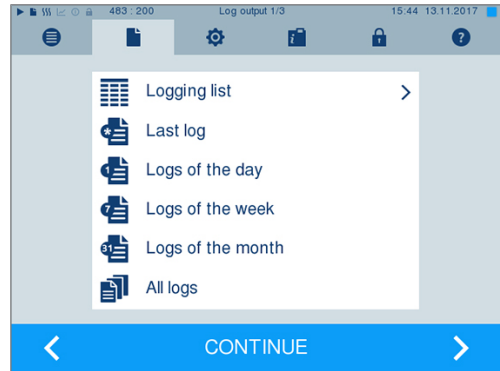

2. A list is displayed with all text logs that have been saved in the internal memory. To facilitate the search, you can filter the log sorting sequence by date, program or outcome by selecting the top line.

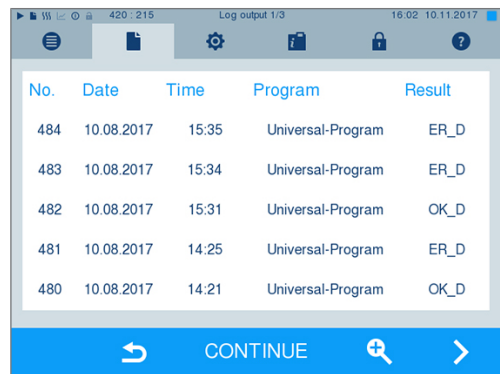

3. Select a log and press **CONTINUE**.
4. Select an output medium and press **OUTPUT**.

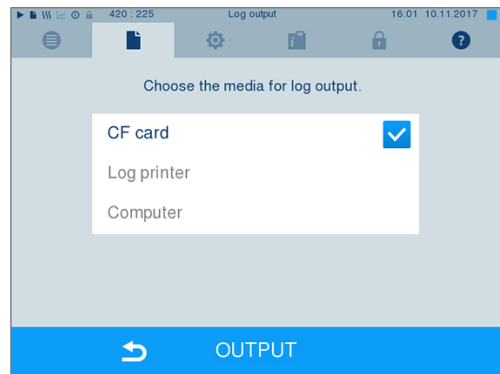

Output the daily, weekly logs, etc.

Proceed as follows e.g. to output all the logs of a week:

1. Navigate to the **Log output** menu, and select the **Logs of the week** option.

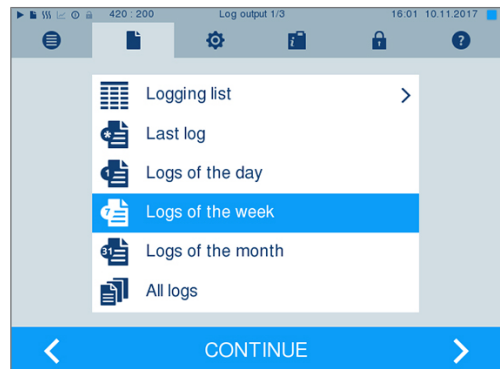

2. Press CONTINUE.
3. Select an output medium and press OUTPUT.

Proceed in a similar fashion to output the last log or all the logs of that day or month or all logs.

Finding logs

PLEASE NOTE

If possible, do not rename the directories because otherwise, logs will be stored both in the renamed directory and in the device directory automatically regenerated by the steam sterilizer.

Storage location for logs

When transferring the logs to a CF card, they will be stored in a separate folder in the main directory.

Transfer of the logs to a computer via the network and using the MELAG ▶FTP server allows you to work directly in the FTP server program to determine directly where on your computer the device directory with the log files is to be saved. With output via ▶TCP and MELAtrace, you can work directly in the program to determine the folder in which they are to be saved.

Log directory

A folder is created on all memory media (CF card or computer) after log output containing the encoded serial number of the steam sterilizer concerned. The folder name consists of five characters identical with the first five characters of every log (e.g. B5002). This folder contains sub-folders with the month of log generation, e.g. 01_2025 for January 2025. This contains all logs generated by the steam sterilizer this month. The device directory is entered in the main directory on the ▶CF card.

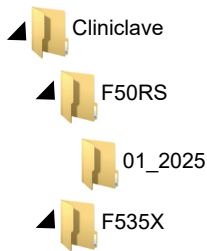

The steam sterilizer checks the storage medium for every type of log output (immediate output after completed program run or transfer of several logs at once). If a directory does not exist, it automatically creates a directory for the device and the month. If the logs are output repeatedly to the same storage medium, a directory named “duplicate” is created there under the device directory.

Further information pertaining to the meaning of the file endings on the logs is available in section [Subsequent log output](#) [▶ page 39].

Example log of a successfully completed program

<pre> !0 01100DDUSN01 !1 F50P100B.PRO ----- 10 MELAG Cliniclave 45 D ----- 15 Programm: Universal-Program 20 Program type: 134 °C wrapped 25 Date: 07/12/2025 30 Daily batch: 11 Total: 00011 34 ID load: 1001 35 ID approval: 1001 36 Indicators changed: deactivated 37 Batch approved: deactivated ===== 40 Universal-Program successfully completed 42 = = ===== 45 Temperature: 135.4 +0.18/-0.19 °C 50 Pressure: 2.18 +0.01/-0.01 bar 55 Plateau time: 05 min 30 s 60 Conductivity: 6 µS/cm (1293:72.9) 65 Start time: 20:19:28 70 End time: 21:07:47 (48:19 min) ===== 80 SN:2025C45D0901 ===== 81 MR V3.240 12/10/2025 82 Para V3.222 13/10/2025 83 BO V3.319 12/10/2025 ----- Step Time t[m:s] P[mbar] T[°C] SP-S 0:00 0:00 1014 115.6 SK11 0:37 0:37 1768 112.6 ... SF12 4:11 0:29 509 112.3 SF13 4:35 0:24 1646 118.7 SF21 4:48 0:13 1306 118.3 SF22 5:38 0:50 191 113.8 SF23 6:13 0:35 1833 121.6 SF31 6:34 0:21 1311 119.4 SF32 7:23 0:49 208 111.4 SF33 8:01 0:38 1923 121.2 SF41 8:24 0:23 1309 119.0 SF42 8:58 0:34 411 103.9 SF43 9:28 0:30 1733 117.8 SH01 10:17 0:49 2873 131.9 SH02 10:37 0:20 2881 132.0 SS01 11:27 0:50 3068 134.1 SS02 16:57 5:30 3182 135.5 SA00 17:42 0:45 1302 112.1 SI01 22:44 5:02 111 116.7 ... SB10 48:12 0:27 812 115.4 SB20 48:18 0:06 923 115.7 SP-E 48:19 0:01 926 115.6 >> Never change the code in the following line << 01004162271431B28355772AE6B57ADBCB7E4E33 BAD9726B2FA0F21C35C1163FB01A3212051D7144 1CDB905EF84F796276A30186C03200D841E7074F 1D95EB05506D7D2F570B782541402C7750428EBA A6B2F2193974164CAD55654107BAE108F7C6E46 168873EE811EF43E0822632831E3F25F6E806F37 5F5A38CED888615F1618F38F370C4C27205C836B >> Batch log proof of authenticity << ----- 0.00 0.0 0.0 0.0 ---.- 0.0 -edk---etm---etd---etp---etv---ett-END- </pre>	<pre> !0 ID number !1 File name ----- 10 Steam sterilizer type ----- 15 Program name 20 Program sterilization parameters 25 Date 30 Daily and total batch number 34 User ID program start 35 User ID program end 36 Batch indication 37 Batch approval ===== 40 Control message 42 Warning or malfunction message upon program abort ===== 45 Sterilization temperature with max. deviations 50 Sterilization pressure with max. deviations 55 Plateau time 60 Conductivity of the feed water 65 Time at program start 70 Time at program end ===== 80 Device serial number ===== 81 Current version of the device firmware 82 Current version of the device parameters 83 Current version of the user interface ----- Step – Program step Time – Time (min:sec) which has elapsed since the program start t [m:s] – Duration (min:sec) which a program step requires P [mbar] – Chamber pressure T [°C] – Chamber temperature Legend for the program steps: SK – Conditioning SF – Fractionation SH – Holding SS – Sterilization SA – Pressure release ST – Drying SI – Intelligent drying SB – Aeration SP-E – End ----- Proof of authenticity (electronic signature)☐Should never be altered; decoding the code (by MELAG) indicates whether the data was generated on a MELAG steam sterilizer and has been changed. ----- Sensor measurement values are displayed here in the case of a malfunction. The values are helpful for a technician. </pre>
--	--

9 Function checks

Vacuum test

The steam sterilizer can be checked for leakages in the steam system using the ▶**vacuum** test. This determines the leakage rate at the same time.

Perform a vacuum test in the following circumstances:

- Once a month in routine operation
- During commissioning
- Following longer operating pauses
- Following a malfunction (e.g. in the vacuum system)

Perform the Vacuum test with the steam sterilizer in a cold and dry state as follows:

1. Switch on the steam sterilizer at the power switch.
2. Working in the **Programs & Tests** menu, select Vacuum test and press START.

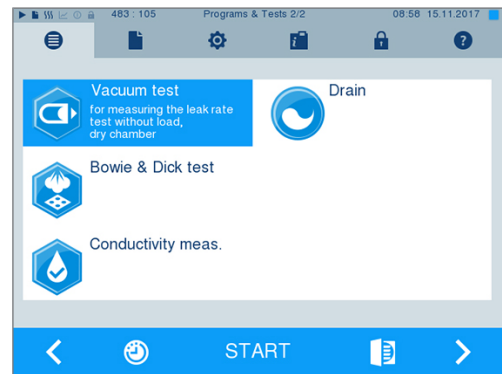

↪ The leakage rate is shown on the display after the vacuum test has been completed. If the leakage rate is higher than 1.3 mbar, a corresponding message will appear.

Bowie & Dick test

The ▶**Bowie & Dick test** serves as evidence of steam penetration of ▶**porous materials** such as e.g. textiles. You can perform a routine function check for evidence of steam penetration. To do so, use the **Bowie & Dick test** program with a suitable test system, e.g. MELAcontrol Bowie & Dick Test. Depending on the application, use either a test system for hollow-body instruments or for porous loads (laundry, etc.). Combination test systems can also be used. Perform the Bowie & Dick test in accordance with the test system manufacturer's specifications.

Perform the Bowie & Dick test as follows:

1. Switch on the steam sterilizer at the power switch.
2. Place the test system in the sterilization chamber of the steam sterilizer and close the door.
3. In the **Programs & Tests** menu, select **Bowie & Dick test** and press START.

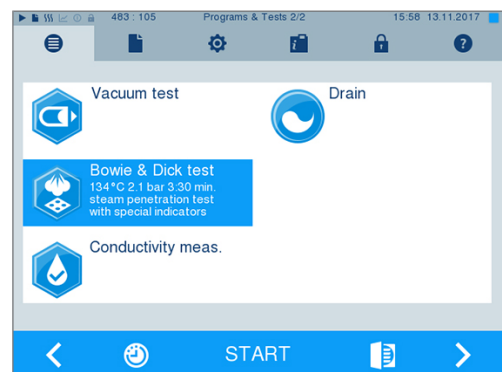

Evaluation of the indicator following the colour change

Depending on the manufacturer batch, indicators often exhibit differing intensities in the colour change resulting from different lengths of storage or other influences. Of crucial importance for evaluating the Bowie & Dick test is not the strength of contrast in the colour change on the test sheet, but the uniformity of the colour change on the indicator. If the indicator indicates an equal distribution of colour change, the de-aeration of the sterilization chamber is without fault. If the indicators are uncoloured or exhibit less colour in the centre in comparison to the end, de-aeration was insufficient. In this case, contact the authorised technician.

MELAcontrol Helix and MELAcontrol Pro test body system

The MELAcontrol Pro and MELAcontrol Helix test body systems consist of a test body and an indicator strip. According to the [▶EN ISO 11140-1](#) standard, MELAcontrol Pro and MELAcontrol Helix are to be classified as type 2 indicators. The two test body systems can be used in large steam sterilizers for hollow-body loads in accordance with [▶EN 285](#). When sterilizing "critical B" category instruments, you should add the MELAcontrol Helix or MELAcontrol Pro test body system to every sterilization cycle as a batch control. Regardless of this, you can perform a steam penetration test in the Universal-Program at any time using MELAcontrol Helix or MELAcontrol Pro. Intended use of the test body system can result in discolouration of the plastic surface. This discolouration does not have any effect on the functionality of the test body system.

Feed water quality

The conductivity of the feed water is subject to automatic monitoring. Nevertheless, the conductivity should be checked every day before beginning routine operation. If a conductivity of 15 $\mu\text{S}/\text{cm}$ or higher is registered, the mixed-bed resin cartridge in the water treatment unit must be changed. A warning message is issued automatically on the display above a conductivity of 20 $\mu\text{S}/\text{cm}$.

PLEASE NOTE

If, despite all warnings, the steam sterilizer continues to be operated with a conductivity of 20 $\mu\text{S}/\text{cm}$ or higher, a test body should be added to each batch to check the steam for non-condensing gases. A malfunction message is shown on the display at 35 $\mu\text{S}/\text{cm}$. Further operation is then no longer possible.

Validation

According to [▶EN ISO 17665](#) and [▶DIN 58946-7](#), validation of the steam sterilizer should be carried out as part of the sterilization processes before starting routine operation.

Renewed performance qualification (requalification)

[▶EN ISO 17665](#) and [▶DIN 58946-7](#) recommend renewed performance qualification (requalification) at regular intervals after 12-24 months.

10 Settings

Only perform settings to the sterilization and logging on the loading side. Display settings (e.g. brightness, key tone etc.) can also be performed on the removal side.

Setting the display position

The display can be set at various positions to permit ergonomic working on the steam sterilizer.

For more information on setting the display position, see Technical manual.

Logging

All settings pertaining to the output of text and graphic logs i.e. output medium, log format, immediate output etc. are performed in menu **Settings > Logging**.

To this end, you are led through a settings wizard.

Immediate log output

In its delivery state, the immediate output of the text and graphic logs via the CF card is activated.

Deactivating immediate output

If you do not want the log to be output directly after the end of the program but rather once a week, you can deactivate the immediate output as follows:

✓ You are in the **Settings > Logging** menu.

1. Remove the check mark in front of the **Immediate output** option.

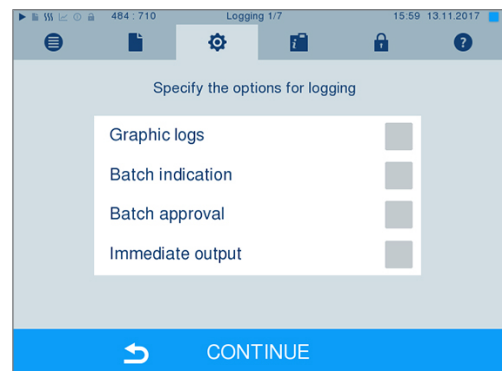

2. Press repeatedly on CONTINUE until you reach the summary window.

3. Press SAVE to accept all settings and leave the menu.

Outputting graphic logs (optional)

PLEASE NOTE

Graphic logs cannot be saved in the internal log memory. A subsequent output of graphic logs is thus not possible.

If you wish to output a graphic log (optional) in addition to a text log, proceed as follows:

- ✓ You are in the **Settings > Logging** menu.
 - ✓ Immediate output is activated.
1. Set a check mark next to the **Graphic logs** option and check whether the check mark is also set next to the **Immediate output** option.
 2. Press CONTINUE and select the CF card and/or computer as an output medium.
 3. If necessary, change the intervals and press CONTINUE.
 4. Working in this window, check whether at least one of the two output media have been selected for text logs.
 5. Check whether the activated output medium is connected (computer) or has been inserted (CF card).
 6. Press repeatedly on CONTINUE until you reach the summary window.
 7. Press SAVE to save the setting.

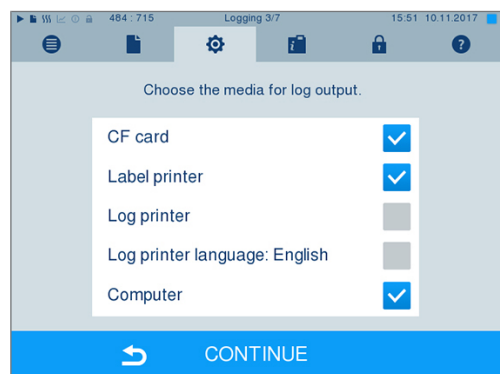
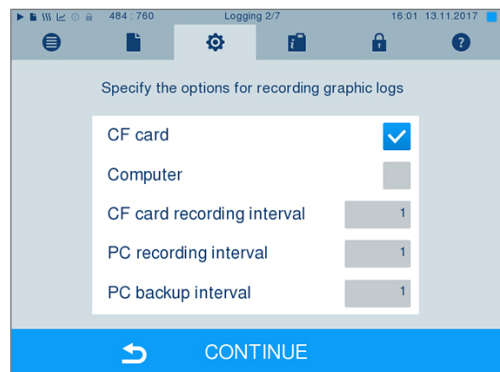
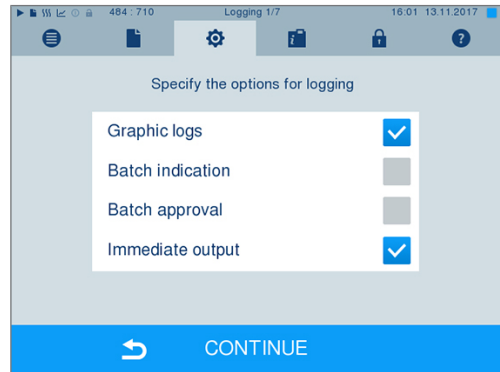

Explanation of the possible settings for graphic recording:

Interval	Description
CF card recording interval	in seconds – Indicates the time intervals in which the program curve is recorded on the ▶CF card. The smaller the time interval, the more exact the curve. In the example, the time interval is set at one second.
PC recording interval	in seconds – Indicates the time intervals in which the program curve is recorded if the computer is selected as output medium. The smaller the time interval, the more exact the curve. In the example, the time interval is set at one second.
PC backup interval	in seconds – Indicates the time interval in which the graphic data from the steam sterilizer is saved on the computer. In the example, the backup interval is set to one second.

Log output in English

If you want to print all text logs on the MELAprint log printer in English, proceed as follows:

- ✓ The text log should be printed in English, regardless of the language of the graphical user interface.
- ✓ You are in the **Settings > Logging** menu.
- 1. Press CONTINUE repeatedly until you reach the window for selecting the output medium.
- 2. Select **Log printer** as the output medium.
- 3. Additionally, select **Log printer language: English**.

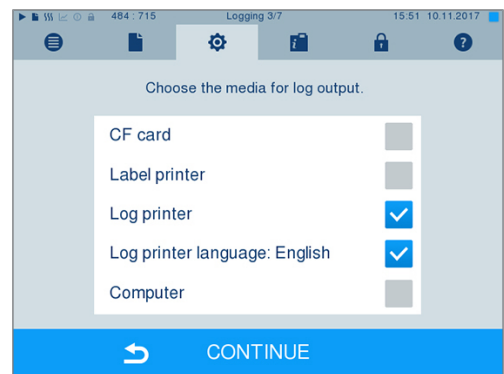

- 4. Press repeatedly on CONTINUE until you reach the summary window.
- 5. Press SAVE to accept all settings and leave the menu.
- ➡ The text logs will be printed in English on the MELAprint log printer.

Using the computer as an output medium

Log transmission can be performed via an FTP server / service or TCP. The following section shows how to set the desired connection:

- ✓ You are in the **Settings > Logging** menu.
- ✓ The steam sterilizer is connected to a computer via a network cable (RJ45).
- ✓ Depending on the output type, an FTP server / service or a suitable program (e.g. MELAtrace) is installed.

1. Press on CONTINUE until you reach the window for selecting the output medium.

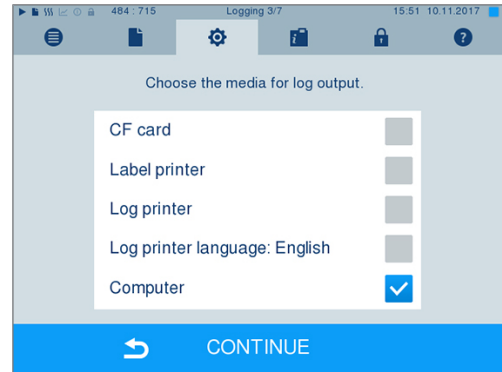

2. Select the computer as an output medium and press CONTINUE.

➔ The selection window opens and asks whether the connection to the computer should be effected via FTP or TCP.

Connection via FTP

- ✓ An FTP server or an FTP service is installed on the computer.

1. Select **Connection via FTP**. The lower pushbutton displays the current user data settings (standard user name: Year of construction + manufacture number; Password MELAG12345).



2. Press the lower pushbutton to change the pre-set TCP user data. The display switches to the settings window.

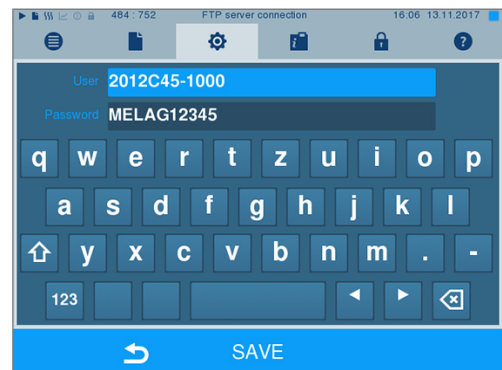

3. Enter the user name and password and confirm with SAVE.

Connection via TCP

✓ A suitable documentation software e.g. MELAtrace is installed.

1. Select **Connection via TCP**. The TCP port currently set is displayed on the lower pushbutton (Standard TCP port: 65001).



2. Press on the lower pushbutton to change the pre-set TCP port.

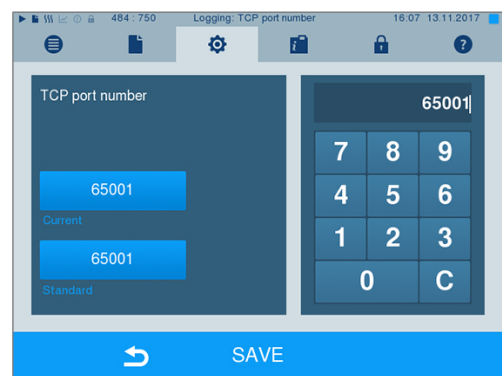

3. Delete the most up-to-date TCP port using button 'C'; enter another TCP port.

4. Confirm with SAVE.

IP addresses

PLEASE NOTE

The setting up of the (practice) network will require in-depth understanding of the network technology. Errors in the handling of IP addresses can result in malfunctions and data loss in your practice network.

- IP addresses may only be set by the (practice) network system administrator.

As a standard, the device is assigned IP addresses in the factory, which all belong to a common network with the subnet mask stated in the following.

Device	IP address	Remarks
Steam sterilizer	192.168.40.40	Pre-set ex works
Computer	192.168.40.140	Pre-set ex works
MELAprint 42/44 log printer	192.168.40.240	Pre-set ex works
MELAprint 60 label printer	192.168.40.160	Pre-set ex works
Gateway	192.168.40.244	Not relevant within a network
Subnet mask	255.255.255.0	Possibly to be adopted by customer network

When integrating the device into an existing (practice) network, the following requirements must be met:

- ✓ The IP addresses listed in the table have not yet been assigned in the (practice) network.
- ✓ The device cannot be automatically administered in a dynamic (practice) network (i.e. a DHCP network).

1. Select the **Settings > Logging** menu.
2. Working in the logging assistant, navigate to the window in which the IP addresses of the individual device are listed.

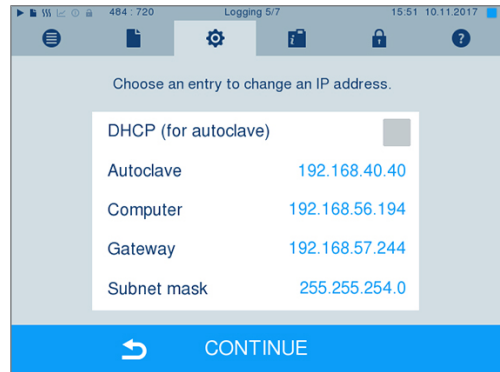

3. Select the steam sterilizer [Autoclave], for example.

4. Press the number block that you wish to change.

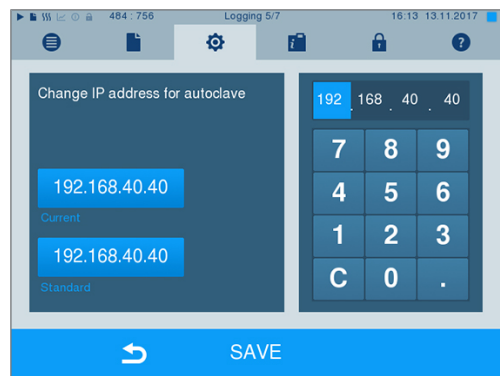

5. Press the button 'C' to delete the digits. Enter a new number block.
6. Press SAVE to accept all settings and leave the menu.
7. Proceed in a similar fashion with the other device that are to be integrated in the network.

Log formats

Different data are issued depending on the nature of the log format.

- ▶ The log format is determined under **Settings > Logging**.

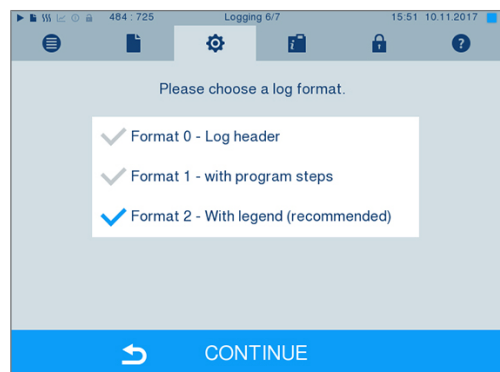

You can choose between the following formats:

Format	Description
Format 0	Short form – only the log header is output.
Format 1	The log header and the program steps are output.
Format 2	Standard format – in addition to the log header and the program steps, a key is displayed explaining the individual program steps. In logs output via the log printer MELAprint, the corresponding legend row is always located under the row to which it refers.

User administration

An ID and individual user PIN can be issued to every user with which to authenticate him/herself, so as to enable reliable traceability via the clearance process. You can determine the necessity of user authentication via a PIN in the **User administration** menu. Activation of this option documents the user ID and the outcome of the approval procedure in the log header.

Adding a user

1. Select the **Settings > User administration** menu.

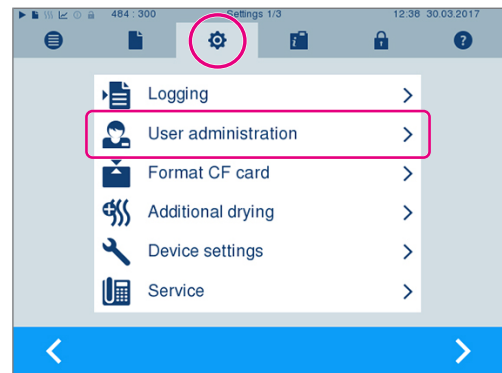

2. Entry of the Admin PIN is necessary to reach the **User administration** menu and undertake settings. Enter the Admin PIN (standard 1000) and confirm with LOGIN.

➡ The display switches to **User administration** window.

3. Select menu **User list** to display the user list.

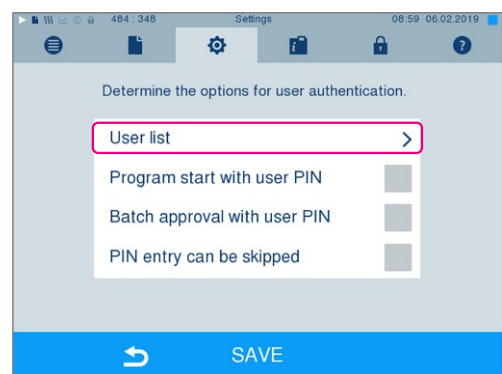

- Select a free ID and select EDIT. in order to create a new user. The first ID is reserved for the Admin PIN.



- Enter a 4-digit PIN in the right-hand key pad for the selected user ID.

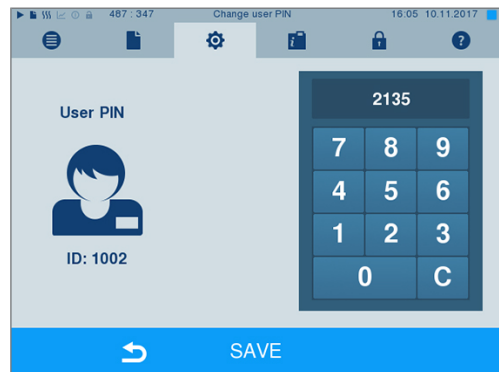

- Press SAVE to accept all settings and leave the menu.

Deleting a user

- Select the **User administration** option as described above and open the user list.



- Select the user ID that you wish to delete.

- Press  to delete this user.

↳ A warning is issued.

- Confirm the warning with YES.

↳ The PIN number of this ID is set to "0".

↳ A new PIN can be issued for this user ID at any time.

Changing the Admin PIN

PLEASE NOTE

If you forget the Admin PIN, consult your stockist/MELAG customer services provider.

The Admin PIN (standard: 1000) can be edited like every other user PIN and should be changed after delivery.

User authentication for sterilization

The user authentication can be set to ensure exact logging and verification. User authentication is performed by entry of the user PIN. The following settings are possible:

- Query user authentication upon program start
- Query user authentication upon program end
- Query user authentication upon program start and end
- You can skip the query user authentication

Determining options for the user authentication

1. Select the **Settings > User administration** menu.

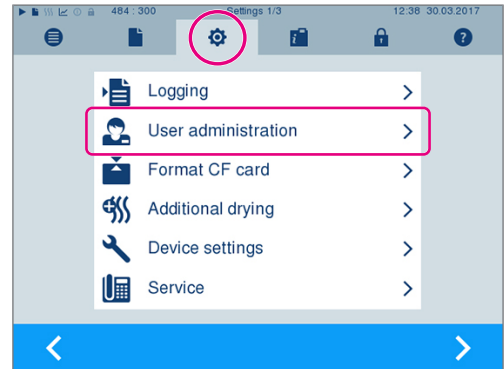

2. Entry of the Admin PIN is necessary to reach the **User administration** menu and undertake settings. Enter the Admin PIN (standard 1000) and confirm with LOGIN.

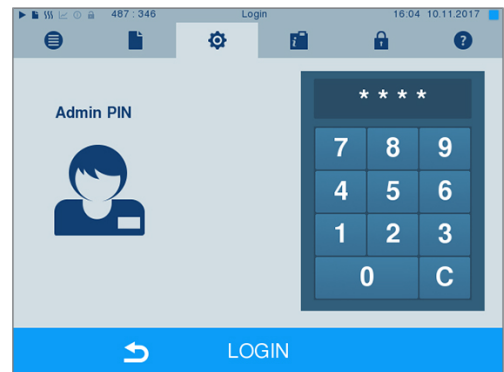

↳ The display switches to **User administration** window.

3. Set a checkmark next to **Program start with user PIN** to perform user authentication upon every program start. The program will start only after entry of the user PIN.

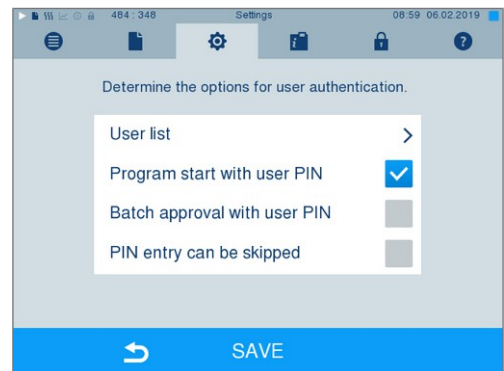

- Set a checkmark next to **Batch approval with user PIN** to perform user authentication upon every program end. The device door will open following program end only after the user PIN has been entered.

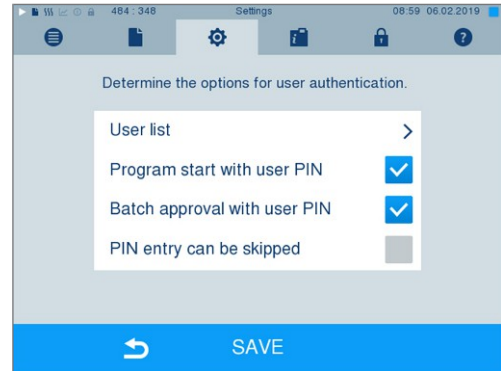

- Set a checkmark next to **PIN entry can be skipped** to enable the user PIN query to be skipped.

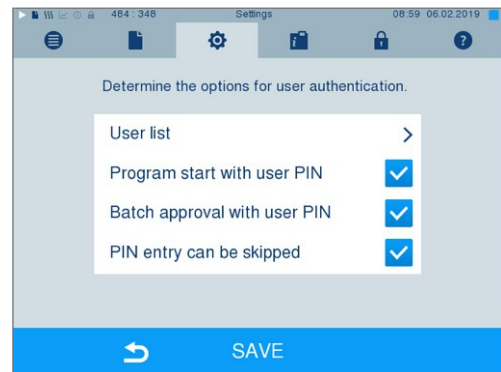

→ The user PIN query continues to be displayed before program start or after program end. Press  to skip user authentication.

- Press **SAVE** to accept all settings and leave the menu.

Formatting the CF card

Only format the CF card on the loading side.

NOTICE

Warning of data loss

All data stored on the CF card is deleted during formatting.

- Check whether important data is stored on the CF card.
- Save any logs or other data on the computer or another memory medium.

- Insert the CF card in the steam sterilizer card slot correctly (tangible raised bar on the edge pointing back right). Do not use force.
- Select the **Settings > Format CF card** menu.
- To start formatting, press the **OK** button.

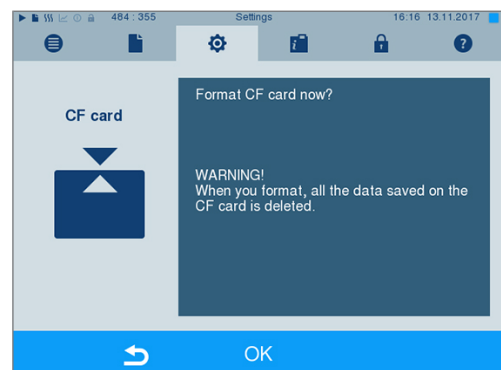

4. Confirm the security query with YES. You can remove the CF card as soon as formatting has been completed.

Additional drying

Selecting additional drying extends the drying time of conventional drying by 50 %. Activating intelligent drying restricts the criteria for ending the drying phase.

Activating/deactivating additional drying for all program runs

1. Select the **Settings > Additional drying** menu.

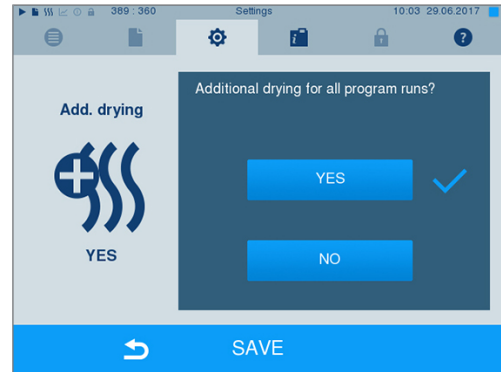

2. Press YES or NO to set whether additional drying should be performed during all subsequent program runs.
3. Confirm with SAVE.

Activating/deactivating additional drying for the current program run

You can activate or deactivate additional drying exclusively for the current program during the program run and into the sterilization phase. The settings during the program run are not carried over for the subsequent program runs.

1. Select the desired program.
2. Press START.
3. Select the **Settings** menu.

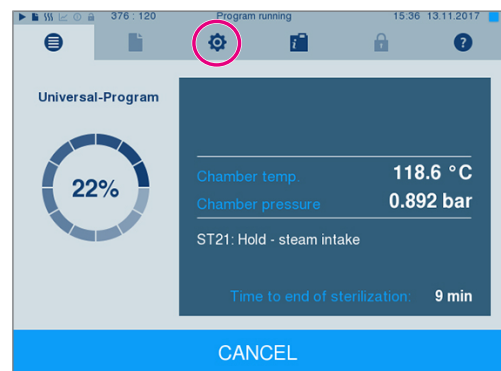

4. Check or uncheck the option **Additional drying**.

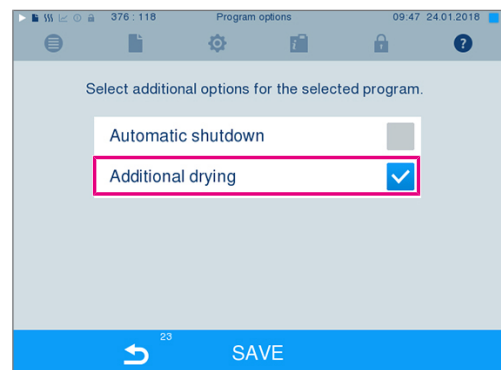

5. Press SAVE to accept all settings and leave the menu.

Intelligent drying

In contrast to a conventional time-controlled drying procedure, in which the duration of the drying phase is determined by the program, the duration of the intelligent drying is automatically calculated using the residual moisture in the sterilization chamber. A number of factors play a role in this process including the type of load, whether it is wrapped or unwrapped, the load quantity, and the distribution of the load in the sterilization chamber, see [Loading the steam sterilizer](#) [▶ page 21].

Intelligent drying is activated in the delivery state. Should you wish to deactivate intelligent drying, proceed as follows:

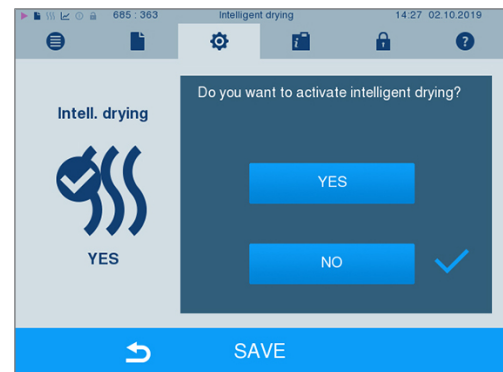

1. Select the **Settings > Device settings > Intelligent drying** menu. The display switches to the corresponding window.
2. If you wish to deactivate intelligent drying, select NO.



3. Press SAVE to accept all settings and leave the menu.

Date and time

Correct ▶batch documentation requires the correct date and time setting on the device. Ensure that you take into account the clock change in autumn and summer, as this is not adjusted automatically. Set the date and time as follows:

1. Select the **Settings > Date & time** menu.
2. Select the parameters which you wish to change (day, month, year / hour, minute).
 - ↳ The marked parameter is depicted light blue, here e.g. the day.
3. Change the respective value using  and . Repeat this step for all the parameters which you wish to change.
4. Press SAVE to accept all settings and leave the menu.
 - ↳ The display is restarted.

Brightness

1. Select the **Settings** > **Brightness** menu.
2. Press **-** or **+** to adjust the brightness and contrast on the display.

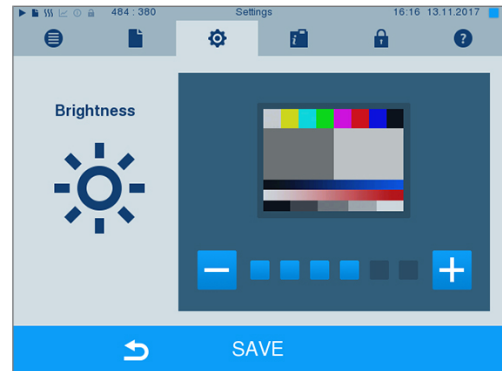

3. Press SAVE to accept all settings and leave the menu.

Volume

1. Select the **Settings** > **Volume** menu.
2. Press **-** or **+** to adjust the volume.

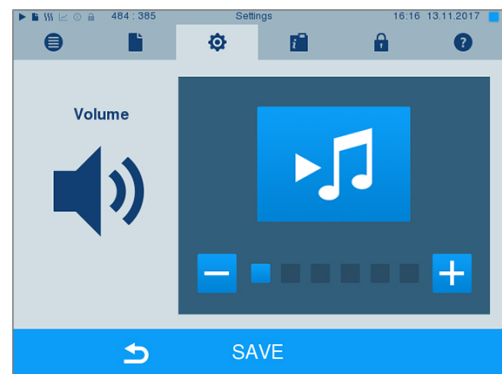

3. Press SAVE to accept all settings and leave the menu.

View

You can choose between classic and modern view.

Switching from MODERN to CLASSIC

1. Select the **Settings > View** menu. The display switches to the settings window.

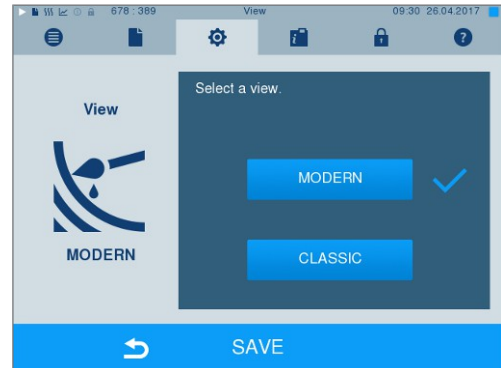

2. Press the CLASSIC button. The design changes immediately.

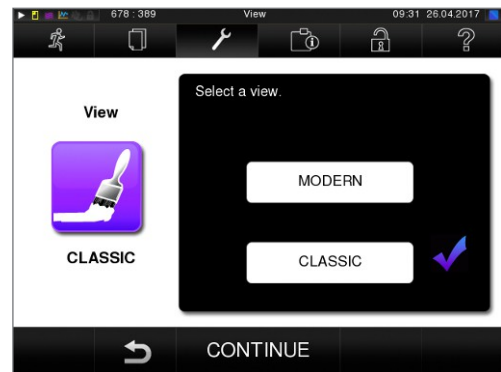

3. Press CONTINUE.
4. Tap on a colour box to change the background colour. The white frame around the colour box indicates which colour is currently selected.
 - ↳ The background colour changes immediately.
5. Press SAVE to accept all settings and leave the menu.

Switching from CLASSIC to MODERN

1. Select the **Settings > View** menu.

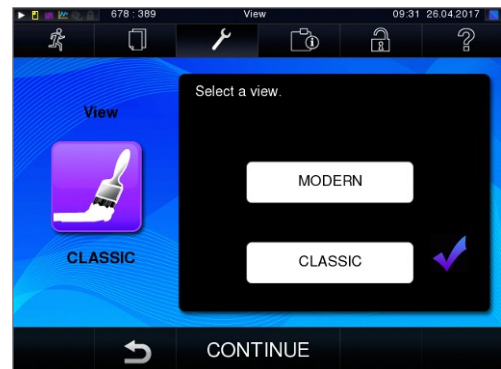

2. Press the MODERN button.
 - ↳ The design changes immediately.
3. Press SAVE to accept all settings and leave the menu.

Key tone

1. Select the **Settings > Key tone** menu.
2. Press YES or NO to set whether a tone should be emitted every time a pushbutton is pressed. This can be deactivated at any time.

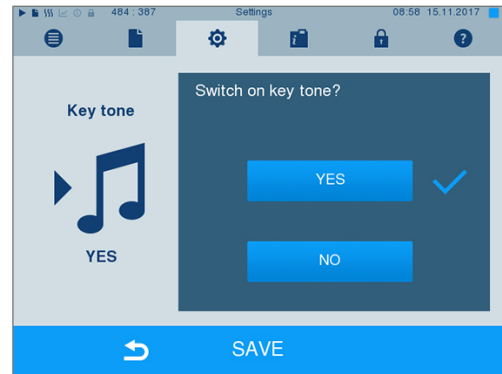

3. Press SAVE to accept all settings and leave the menu.

Screensaver

A screensaver can be activated to protect the display in standby operation. This displays a continuous slide show of any pictures.

Select images for the slide show

1. Select the **Settings > Screensaver** menu.

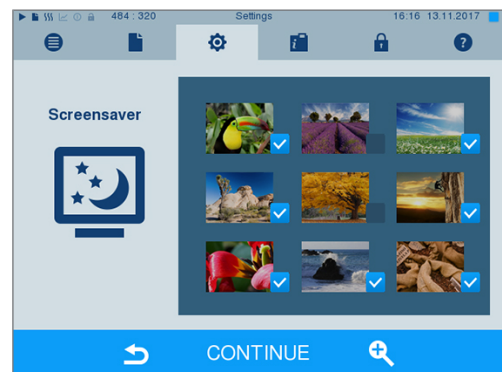



2. Tap on a picture to select it. The white frame around the picture indicates which picture is currently selected.
3. Repeated tapping on the picture selects/deselects it for the slide show.
 - ↳ The checkmark on the lower right-hand corner indicates whether the picture has been selected for the slide show.
4. Press CONTINUE to make further settings.

Setting the display duration of the pictures and the waiting time of the slide show

Proceed as follows to alter one of the named options:

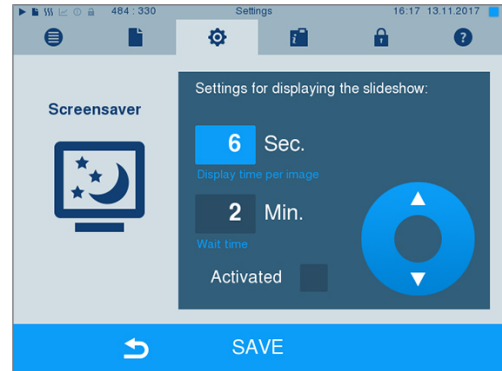
1. Select the parameter directly that you wish to change. The marked parameters are displayed light blue.



2. Change the respective parameter value via the  and  pushbuttons.
3. Press SAVE to accept all settings and leave the menu.

Explanation of the slide show options

Display duration per picture	Indicates the time in seconds between the display of two separate pictures.
Waiting time	Indicates how long the display remains in normal mode before the slide show starts.
Activated	Setting/unsetting the checkmark activates/deactivates the screensaver.



Log printer MELAprint 42/44

If you wish to output the sterilization log via the log printer MELAprint 42/44, you need to set this on the steam sterilizer once. The user manual of the log printer indicates how to set it up.

MELAprint 60 label printer

If you wish to output the sterilization log via the MELAprint 60 label printer, you need to set this on the steam sterilizer once. The user manual of the label printer indicates how to set it up.

Sensitivity

1. Select the **Settings > Touchscreen sensitivity** menu.
2. Press  or  to adjust how much pressure must be applied when touching a button to trigger an event.

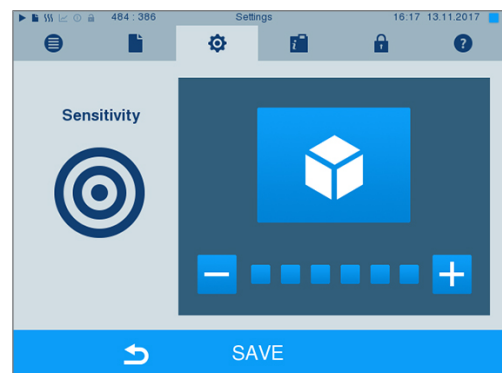

3. Press SAVE to accept all settings and leave the menu.



Energy-saving mode

If the steam sterilizer is not to be switched off during longer operating pauses, it can be operated in energy-saving mode. This reduces the time that is required in order to pre-heat the ▶double jacket steam generator to the necessary start temperature after deactivation. Two waiting times can be set in energy-saving mode:

Waiting time 1 (W1): After a pre-set waiting time of 3 min, the temperature of the ▶double jacket steam generator falls to 103 °C. The program run time increases by approx. 2 min upon the next start.

Waiting time 2 (W2): After a pre-set waiting time of 25 min (Cliniclave 45 D) und 40 min (Cliniclave 45 MD) the ▶double jacket steam generator is no longer heated. Accordingly, the length of the program run time increases by approx. 5 min upon the next start, depending on the length of the operating pause, as the double jacket steam generator must first be pre-heated to the necessary start temperature.

In order to set up the energy saving mode, proceed as follows:

1. Select the **Settings > Energy saving mode** menu.
2. Select waiting time 1 directly by touching.
 - ↳ The area is displayed light blue.
3. Press  or  to adjust the minutes.
4. Repeat the step for waiting time 2.
5. Press CONTINUE.

Switching off the display

You can choose whether the display is to be switched off when the steam sterilizer is in energy-saving mode (waiting time 2).

1. Set the check-mark next to **Activated**, and set the number of seconds after which the display is to be deactivated.

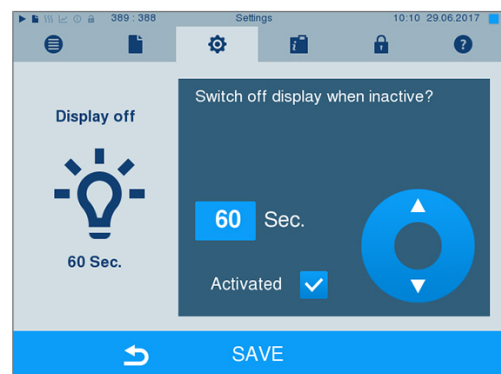

2. Press SAVE to accept all settings and leave the menu.
3. Switch the display back on by touching the screen.

11 Maintenance

PLEASE NOTE

Perform the work on the loading and removal side of your device.

Servicing intervals

Interval	Measure	Device component
Weekly	Check for soiling, deposits or damage	Sterilization chamber including door gasket and chamber sealing surface, support frame for load
Every 2 months	Clean, check and oil the locking spindle and nut	Door mechanism
After 4000 cycles but no later than 12 months	Maintenance	by the authorised customer services working in accordance with the maintenance instructions
As required	Cleaning the surfaces	Housing parts

Cleaning

NOTICE

Warning of material damage from incorrect cleaning

Inappropriately performed cleaning can lead to the scratching of and damage to surfaces as well as the development of leaks in sealing faces. This also favours the development of soiling deposits and **corrosion** in the **sterilization chamber**.

- Comply with all information regarding cleaning of the parts affected.
- Do not use any hard objects for cleaning such as a metal saucepan cleaner or a wire brush.

Sterilization chamber, door gasket, mount, trays

To maintain the value of your device and to avoid persistent contamination and deposits, MELAG recommends weekly cleaning of the surfaces. Use the Chamber Protect chamber cleaning set or, if not available, a neutral liquid cleaner or spirit.

PLEASE NOTE: Note the instructions for use of the cleaning agent.

The following must be fulfilled or present:

- ✓ The door is open.
 - ✓ Trays or sterile containers, the associated mount, and the slide rail have been removed from the sterilization chamber.
1. Apply the cleaning agent on a lint-free cloth.
 2. Use a lint-free cloth to uniformly spread the cleaning agent on the surfaces to be cleaned.
PLEASE NOTE: Do not allow cleaning agent to get into the pipes coming from the sterilization chamber.
 3. Allow the cleaning fluid to act and evaporate for a sufficient time. This may take a few minutes.
 4. Wet a new lint-free cloth with plenty of demineralised water.
 5. **NOTICE! Warning of material damage. Residues of cleaning agents can ignite or cause deposits on the instruments. Wipe down the cleaned surfaces thoroughly.**
After wringing out the cloth, repeat this process if necessary.
 6. Allow the cleaned surfaces to dry completely. This may take a few minutes.
 7. Wipe the cleaned surfaces with a dry, lint-free microfibre cloth.

Housing parts

Where necessary, clean the housing parts with a neutral fluid cleaner or spirit.

Comply with the following specifications when disinfecting the housing parts:

- Use wipe disinfectants and not spray disinfectants. This prevents disinfectant from getting into inaccessible places or ventilation slots.
- Only use alcohol-based surface disinfectants (ethanol or isopropanol) or alcohol-free disinfectants based on quaternary ammonium compounds.
- Do not use disinfectants containing secondary and tertiary alkylamines or butanone.

Avoiding staining

Only proper cleaning of the instruments prior to sterilization enables you to avoid residue from being released from the load under steam pressure during sterilization. Loosened dirt residue can clog the filter, fittings and valves of the device and deposit themselves on the instruments and in the sterilization chamber as deposits and stains.

All steam-conducting parts of the device consist of non-rusting material. This rules out the development of rust caused by the device. Any rust which develops is always extraneous rust.

Incorrect instrument reprocessing can result in the accretion of rust even on stainless steel instruments of leading manufacturers. Often, a single instrument which drops rust can suffice to cause the development of rust on other instruments or in the device. Remove foreign rust from the instruments using chlorine-free stainless steel cleaning fluid (see [Cleaning](#) [▶ page 62]) or send the damaged instruments to the manufacturer.

The extent of stain accretion on the instruments is also dependant on the [▶feed water](#) used for steam generation.

Replacing of the door gasket

Replace a worn, porous or cracked door gasket immediately:

1. Remove the door gasket from the groove in the round door.
2. Insert the new door gasket into the groove at four points that are evenly distributed over the door rim.
3. Press the gasket into the groove in each of the four quadrants. Ensure even distribution.

Checking and oiling the door lock

NOTICE

Warning of material damage from wear

If the door lock is not oiled regularly it can become worn. Pressure-tight closing of the door can no longer be ensured.

- Check and oil the door lock every two months.
- Use MELAG oil (included in the scope of delivery) to oil the door lock.

Check and oil the door lock every two months as follows:

1. Clean the locking spindle and nut with a non-fuzzing cloth.
2. Insert the test gauge into the door lock nut as far as it will go and turn it 180°. If this is not possible or resistance can be felt, the door lock nut is worn. Have the door lock nut replaced by an authorised technician.
3. Put two drops of oil in the door lock nut.

➔ The oil will be distributed automatically by closing the door.

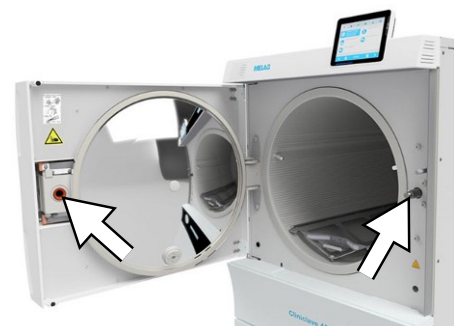

Replacing the sterile filter

Comply with the following for safe handling:

- The sterile filter is no longer effective if it has become wet. Stop using the sterile filter and replace it.
- Do not replace the sterile filter during a program run.
- 1. Unscrew the sterile filter counter-clockwise from the holding socket.
- 2. Replace the sterile filter with a new sterile filter.
- 3. Turn the new sterile filter clockwise straight into the holding socket.

Maintenance

Comply with the following for safe handling:

- Maintain the specified maintenance intervals. Continuing operation beyond the maintenance interval can result in malfunctions in the device.
- Have maintenance performed only by trained and authorised technicians using the original MELAG maintenance set.
- If components that are not included in the maintenance set have to be replaced during maintenance, only original spare parts from MELAG may be used for the replacement.

Regular maintenance is vital to ensure reliable operation and value retention of the device. All function and safety-relevant components and electrical units must be checked during maintenance and replaced where necessary.

Maintenance must be carried out regularly after 4000 cycles, however, after 12 months at the latest. The steam sterilizer will issue a maintenance message at the relevant time.

Maintenance of the reverse osmosis unit

The conductivity of the feed water is measured automatically before every program run. If the water quality falls further, the display of the steam sterilizer will show the message **Poor feed water quality** a program start is however still possible.

If the water quality falls further, the display of the steam sterilizer will show the message **Feed water quality insufficient**. A program start is no longer possible. Perform punctual maintenance on your reverse osmosis unit to avoid device downtime.

Further information and detailed maintenance instructions are listed in the user manual of the reverse osmosis unit.

When in standby mode, the conductivity can also be measured manually in menu **Programs & Tests** (see [Feed water quality](#) [▶ page 44]).

12 Pause times

Frequency of sterilization

Pause times between the individual programs are not necessary, as the sterilization chamber is maintained permanently at the same temperature. After the end/abort of the drying time and removal of the [sterile material](#), you can load the steam sterilizer again and start a new program.

Duration of the operating pause

Duration of the operating pause	Measure
Short pauses between two sterilization processes	<ul style="list-style-type: none"> • Keep the door closed to save energy • Set the energy-saving mode correspondingly
Pauses which last longer than an hour	<ul style="list-style-type: none"> • Switch off the steam sterilizer
Longer pauses e.g. over night or the weekend	<ul style="list-style-type: none"> • Open the door and switch off the steam sterilizer • Leave the door ajar to prevent premature wear and the sticking of the door gasket • Shut off the cold water inflow and if present, the water inflow of the water treatment unit
Longer than two weeks	<p>Before starting the operating pause:</p> <ul style="list-style-type: none"> • Open the door and switch off the steam sterilizer • Leave the door ajar to prevent premature wear and the sticking of the door gasket • Shut off the cold water inflow and if present, the water inflow of the water treatment unit <p>Following the operating pause:</p> <ul style="list-style-type: none"> • Perform a vacuum test • After a successful vacuum test, perform an empty sterilization run in Quick-Program S

After pauses, perform the checks described in chapter [Function checks](#) [▶ page 43] depending on the length of pause.

Decommissioning

When decommissioning the device for a long pause (e.g. due to holiday), proceed as follows:

1. Empty the double jacket steam generator, see [Emptying the double jacket](#) [▶ page 66].
2. Switch off the steam sterilizer at the power switch.
3. Disconnect the power plug from the socket and if necessary, allow the device to cool.
4. Should the steam sterilizer need to be transported, wait until the container on the air gap has emptied automatically (approx. 10 min).
5. Close the water feed.
6. Shut off if present, the water inflow of the water treatment unit.

Emptying the double jacket

You have the option of draining the water in the double jacket steam generator easily via program Drain. In order to do so, the steam sterilizer is heated once, building up pressure in the double jacket so that the water can be drained fully from the double jacket steam generator.

1. Switch on the steam sterilizer at the power switch.
2. Working in menu **Programs & Tests** select program Drain and press START.

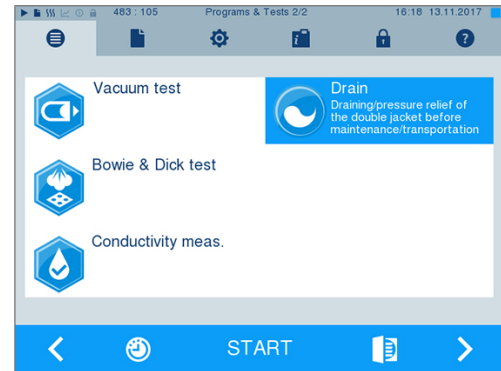

3. Following notification **Draining successful** switch off the steam sterilizer, so that water is not fed into the double jacket.

Transport

⚠ CAUTION

Warning of injury

Lifting and carrying the device incorrectly can cause spinal damage, crushing injuries and bruising.

- MELAG recommends carrying the device with at least six people.
- Transport the steam sterilizer using the carrying handles or transport bars included in the scope of delivery.
- Wear protective gloves and safety shoes when moving the steam sterilizer.
- Comply with the safety regulations that apply to you.

Comply with the following for safe handling:

- Store and transport the device frost-free.
- Avoid strong shocks/vibrations.
- Store the device in a fashion protected against moisture.

Preparing the steam sterilizer for transport

1. Decommission the device, see [Decommissioning](#) [▶ page 65].
PLEASE NOTE: It is not necessary to empty the steam generator when transporting the steam sterilizer within the practice (level ground).
2. Disconnect the outlet hose and inflow hose from the connections on the walls. Guide both hoses and the power cable into the floor unit.
3. Remove the casing panels from the loading and removal side of the partition wall (four casing panels per side).
4. Remove both plastic caps on the side wall of the loading side.
5. Screw two carrying handles onto the loading side.
6. Should you wish to leave the mounts and trays or cassettes in the sterilization chamber during transport, protect the surface of the round blank. To do so, place e.g. some foam or bubble wrap between the round blank and mount.
7. Close the steam sterilizer door before moving it.
8. Release the holding brake on the casters.
9. Remove the device on the loading side.

Transport within the practice

Comply with the following provisions during transport within a room or the practice:

- Prepare the steam sterilizer for transport, see [Transport](#) [▶ page 66].
- If necessary, screw on two further carrying handles on the removal side of the device.
- Use the casters to transport the device. It is not necessary to carry the device.
- Protect the practice floor from any damage from the weight of the device.
- Do not roll the steam sterilizer over any uneven surfaces or thresholds. Lift the device over uneven floors or doorsteps using the carrying handles.

Transport over long-distance / dispatch

When transporting the steam sterilizer over long distances, between different floor levels or dispatching it, comply with the following:

- For transport over longer distances, during the danger of frost and/or for dispatch, an [authorised technician](#) must prepare the steam sterilizer in accordance with the instructions and empty the [steam generator](#) and the container of the air gap entirely, see [Decommissioning](#) [▶ page 65].
- Use the casters to transport the device.
- Carry the device only in exceptional circumstances (e.g. between different floor levels without an elevator or for loading purposes within the scope of relocations). MELAG recommends carrying the device with at least six people.
- Only ever carry the steam sterilizer over short distances.
- Take appropriate measures to secure the steam sterilizer for dispatch. Consult your stockist or an authorised MELAG customer service provider.

Proceed as follows:

1. Prepare the steam sterilizer for transport, see [Transport](#) [▶ page 66].
2. Empty the sterilization chamber.
3. Remove the carrying handles from both sides of the device. The carrying handles can be stored in the bracket in the floor unit.
4. If required, fit the transport bars instead. The spacers must sit between the side wall of the device and the transport bar.
5. Fix the transport bars by screwing the four screws tight using a spanner (AF 19).



Ordering further transport bars

If the device and floor unit are delivered separately, the transport bars are included in the scope of delivery. If you need transport bars for transport but don't have any (e.g. due to loss or delivery of your device as a complete dispatch), you

can reorder the transport bars, see [Accessories and spare parts](#) [▶ page 84]. Consult your stockist or an authorised MELAG customer service provider.

Recommissioning after relocation



When recommissioning after changing the location of the device, proceed as for initial commissioning, see Technical manual.

13 Malfunctions

Comply with the following for safe handling:

- Should the device issue the same malfunction message repeatedly, turn off the device and if necessary, inform your stockist.
- The device may only be serviced by ► [authorised technicians](#).

Not all notifications on the display are malfunction messages. Warnings and malfunction messages are issued on the display with an event number. This number serves identification purposes.

	Type of message	Description
	Notification	A number of notifications are messages providing information. They support the operation of the steam sterilizer.
	Warning message	Warnings are displayed when necessary. These contain instructions that apply to you, the operator. Warning messages are not malfunction messages. They help to ensure malfunction-free operation and to recognise undesirable situations. Comply with these warnings early in order to prevent malfunctions.
	Malfunction message	Malfunction messages are issued when it is not possible to ensure safe operation or safety of sterilization. These can appear on the display shortly after activating the steam sterilizer or during a program run. If a malfunction occurs during a program run, the program will be aborted.

Troubleshooting online

All messages with current descriptions can be found in the Troubleshooting portal on the MELAG website (<https://www.melag.com/en/service/troubleshooting>).



Before contacting the technical service

Follow the instructions that appear on the device's display that relate to a warning or malfunction message. The following table contains a summary of the most important events. Should you be unable to find the relevant event, or your efforts do not redress the problem, you can contact your stockist or the MELAG customer service. Have the number of your device, the event number and a detailed description of the malfunction to hand so that we can help you.

Messages

Event	Possible causes	What you can do
248	Vacuum test was carried out despite residual moisture in the sterilization chamber or with a load.	Repeat vacuum test if steam sterilizer is cold and empty.

Warning and malfunction messages

Event	Possible causes	What you can do
61	When using a MELAG water treatment unit: a) Residual air is in the feed system of the water treatment unit after initial commissioning or after replacing the mixed-bed resin cartridge. b) The pressure tank of MELAdem 56/56 M has not been filled sufficiently and/or the tap on the pressure tank has not been opened completely.	a) Acknowledge the malfunction message and start the program repeatedly until the malfunction message is no longer displayed. b) Please note that after initial commissioning of a MELAdem 56/56 M it takes approx. 1 h until the pressure tank is sufficiently full with water. Check whether the tap on the pressure tank has been opened completely.
	When using a central water treatment unit: c) The central water supply has been interrupted or the flow pressure is insufficient.	c) Check that all inlet valves from the central system to the steam sterilizer are open. If necessary, arrange for an inspection of the flow pressure of the central water treatment unit using a flow pressure gauge (min. 0.5 bar at 5 l/min).
	If using an external storage container: d) There is air in the intake line from the storage container to the steam sterilizer. e) The suction filter of the external storage container is blocked.	d) Check whether sufficient feed water is in the storage container; the end of the intake hose is submerged in water and that no air is being drawn in. Note that the container may be max. 1.5 m lower than the steam sterilizer because otherwise water cannot be drawn in. e) Check whether the filter in the external storage container is soiled or blocked and clean if necessary.
63	Very poor feed water quality (conductivity $\geq 35 \mu\text{S/cm}$). a) The mixed-bed resin cartridge, pre-filter or the activated carbon filter of MELAdem 56/56 M is exhausted. b) Poor quality of the feed water in the external water storage container.	a) Replace the mixed-bed resin cartridge and, if necessary, the prefilter and activated carbon filter of the MELAdem 56/56 M as described with the corresponding user manual. PLEASE NOTE: The message may also continue to be shown after the filter has been replaced until the water remaining in the pressure tank has been consumed. Start the draining program once or twice to flush the poor feed water from the pressure tank. The flushing of the pressure tank means that it can take up to 2.5 h for the tank to be filled and become ready. b) Drain and replace the feed water in the external water storage container.
64	see event 63	
65	see event 63	
66	The feed water hose between the water treatment unit and the steam sterilizer is leaking. Air is drawn in with the feed water.	Check that the feed water hose to the steam sterilizer is not leaking and has been connected correctly.
67	The wastewater cannot drain. a) The outlet hose is kinked or laid with large sags. b) The U-trap or building's wastewater pipe is blocked. c) The Quick-Program B and Quick-Program S programs are mainly used. These programs do not perform automatic flushing.	a) Check the installation of the outlet hose. It must be installed without kinking or sagging and at a constant decline. If necessary, use the tensioning device on the underside of the steam sterilizer to tighten the outlet hose. b) Check whether the building's U-trap is blocked. PLEASE NOTE: If you operate multiple devices at the same time, we recommend that you install an additional U-trap. c) Start another program, e.g. Universal-Program, Gentle-Program or Prion-Program to carry out the necessary rinsing.

Event	Possible causes	What you can do
72	Poor feed water quality (conductivity $\geq 20 \mu\text{S/cm}$). The mixed-bed resin cartridge, pre-filter or the activated carbon filter of MELAdem 56/56 M is exhausted.	Replace the mixed-bed resin cartridge and, if necessary, the prefilter and activated carbon filter of the MELAdem 56/56 M as described in the corresponding user manual. PLEASE NOTE: The message may also continue to be shown after the filter has been replaced until the water remaining in the pressure tank has been consumed. Start the draining program once or twice to flush the poor feed water from the pressure tank. The flushing of the pressure tank means that it can take up to 2.5 h for the tank can to be filled and ready.
73	see event 72	
74	see event 72	
75	see event 72	
76	see event 67	
81	a) The door was not pushed shut for long enough with sufficient force; as a result, the thread has become caught. b) The door lock nut has not been greased regularly and is therefore dry.	a) Push the door with force for approx. 3 s until the spindle engages in the door lock nut and the door is closed automatically. A motor sound is audible. b) Check the door spindle and the door lock nut for damage. Clean both and oil the door lock nut with the MELAG oil provided, see Maintenance [▶ page 62]. Use the test gauge to check the door lock nut for wear.
82	a) There are objects in the door area. The door was blocked from outside during the opening process. b) There is still a residual vacuum in the sterilization chamber. Pressure equalisation is not yet completed. c) The door gasket sticks to the seal face of the sterilization chamber.	a) Always keep the area in front of the door free so that it can open unhindered. b) 1. Wait 2 min, and then acknowledge the message with OK. 2. If the door does not open by itself, switch off the steam sterilizer, wait for 5 min and then switch it back on. Try again to open the door. If the door still doesn't open, please contact the technical service. c) If it was possible to open the door (e.g. using the manual door emergency opening, see Manual door emergency-opening [▶ page 18]), then clean the door gasket and the face seal on the sterilization chamber, see Cleaning [▶ page 62].
83	The door does not reach a pressure-tight state after the program start. a) The door gasket and/or the seal face is soiled and or damaged. b) The load blocks the closing sequence. c) The closing mechanism is stiff.	a) Check the door gasket and seal face on the sterilization chamber for soiling, foreign bodies and damage. b) Check whether the load is blocking the door. c) Check the door spindle and the door lock nut for damage. Clean both and oil the door lock nut with the MELAG oil provided, see Maintenance [▶ page 62]. Use the test gauge to check the door lock nut for wear.
84	see event 82	
86	The door has not been closed correctly upon program start.	Push the door with force for approx. 3 s until the spindle engages in the door lock nut and the door is closed automatically. A motor sound is audible.
89	see event 86	

Event	Possible causes	What you can do
102	The wastewater cannot flow away. a) The outlet hose is kinked or sags. b) The U-trap or the building-side outlet line is blocked, or multiple devices have been connected to a single U-trap. c) The chamber filters are blocked.	a) Check the installation of the outlet hose. This must be laid free of kinks or sags and with a constant gradient. b) Check whether the building's U-trap is blocked. PLEASE NOTE: If you operate multiple devices at the same time, MELAG recommends installing an additional U-trap. c) Check whether the chamber filters are soiled/ clogged (at the fixing points under the front and rear of the slide rail), e.g. by packaging residues. If necessary, clean the chamber filters.
103	The sterile filter is soiled/blocked.	1. Check whether the sterile filter suction aperture (centre aperture) behind the service hatch of the steam sterilizer is blocked. If yes, replace it with a new sterile filter, see Replacing the sterile filter [▶ page 64]. 2. If nothing can be recognised, remove the sterile filter and perform a program run without a load. If the program has been ended successfully, the sterile filter is blocked. In this case, replace the sterile filter with a new one, see Replacing the sterile filter [▶ page 64].
104	see event 103	
110	a) The steam sterilizer is overloaded or the load has been arranged badly. b) The mains voltage is too low, poor building voltage supply (e.g. undersized installation, defective socket, multiple devices on a single socket/fuse).	a) Comply with the maximum permissible load quantities, see Loading the steam sterilizer [▶ page 20]. Ensure that the load does not come into direct contact with the steam injection nozzles or cover them. b) Check the on-site installation (e.g. automatic circuit breaker) or test the steam sterilizer at another socket or in another circuit.
111	see event 110	
113	a) The steam sterilizer was switched off at the power switch during a program run. b) The power plug has been disconnected or has not been connected correctly in the socket. c) Power outage in the building supply or the building-side RCD switch has tripped.	a) Never switch off the steam sterilizer at the power switch during a program run. b) Check whether the power plug is connected, the power cable has suffered damage or a loose contact or loose plug connections is the cause. Plug the power plug back into the mains socket. c) Arrange for an inspection of the building-side installation (e.g. automatic circuit breaker) and test the steam sterilizer at another socket or on another circuit.
114	see event 102	

Event	Possible causes	What you can do
124	a) The steam sterilizer is overloaded. b) The steam sterilizer was operated without a mount and the load (especially the textiles) come into direct contact with the chamber wall. c) The chamber filters in the floor of the sterilization chamber are blocked. d) The cooling water in the steam sterilizer is too warm.	a) Comply with the maximum permissible load quantities, see Loading the steam sterilizer [▶ page 20]. If necessary, perform a vacuum test, see Vacuum test [▶ page 43]. b) Always operate the steam sterilizer with a mount and follow the loading instructions, see Loading the steam sterilizer [▶ page 20]. c) Check whether the chamber filters (at the fixing points under the front and back of the slide rail) are soiled/blocked, e.g. by packaging residue. Clean the chamber filter if necessary. d) Check whether the inlet hose heats up during operation. If yes, check whether the hose has been connected to the hot water connection by mistake. PLEASE NOTE: In the summer, heat accumulation in the supply line can lead the water to warm up. Restart the program so that new, cold water is flushed.
125	see event 124	
126	see event 124	
127	see event 124	
131	see event 102	
132	The steam sterilizer is overloaded or the load has been arranged badly.	Comply with the maximum permissible load quantities, see Loading the steam sterilizer [▶ page 20]. Ensure that the load does not come into direct contact with or covers the steam injection nozzles.
133	see event 124	
135	a) The cooling water hose is kinked. b) The inflow filter in the aqua stop of the inflow hose is blocked by soiling in the building supply. If a leakage water detector (water stop) is installed: c) The leakage water detector is without function. d) The inflow filter in the leakage water detector is blocked by soiling in the building supply.	a) Check the installation of the inflow hose. It must be installed without kinking and may not be crushed. b) Unscrew the inflow hose on the water inflow tap and check the inflow filter; clean it if necessary. c) Unplug the leakage water detector control device from the socket, wait approx. 30 s and plug it back in again. A switching noise on the leakage water valve (black box on the water inflow tap) must be audible. d) Clean the inflow filter in the leakage water detector valve as follows: 1. Close the water inflow tap and start a vacuum test. 2. Wait until the device displays a malfunction message and then switch it off. 3. Unscrew the leakage water detector valve on the water inflow tap and check the inflow filter; clean it if necessary.
136	a) The ambient temperature of the steam sterilizer is too hot. The steam sterilizer is installed. The minimum clearances to the surrounding surfaces has not been maintained. c) The door was left open after loading or unloading and hot steam has escaped from the sterilization chamber. d) The filter in the base plate fan is soiled.	Switch off the steam sterilizer and allow it to cool for approx. 1 h. a) The ambient temperature must be below 40 °C. MELAG recommends a maximum temperature of 26 °C. b) Maintain a minimum clearance to the surrounding surfaces, see Technical manual. c) Always close the door after loading or unloading. d) Check whether the fan filter in the base plate of the steam sterilizer is clogged, and replace it if necessary.

Event	Possible causes	What you can do
175	The overheat control of the control heater on L1 (RHK1) has tripped. This notification may be issued in alternation with "E176: ACOUT 02 open".	<ol style="list-style-type: none"> 1. Switch off the steam sterilizer and push in fully the reset button RHK1 behind the service hatch of the steam sterilizer until a switching noise is audible. 2. Acknowledge the malfunction message. 3. Switch off the steam sterilizer and back on again and then perform an empty sterilization run if necessary. The steam sterilizer is now ready for operation.
176	The overheat control of the control heater on L1 (RHK1) has tripped. This message may be issued in alternation with "E175: ACOUT 01 open".	<ol style="list-style-type: none"> 1. Switch off the steam sterilizer and push in fully the reset button RHK1 behind the service hatch of the steam sterilizer until a switching noise is audible. 2. Acknowledge the malfunction message. 3. Switch off the steam sterilizer and back on again and then perform an empty sterilization run if necessary. The steam sterilizer is now ready for operation.
179	<ol style="list-style-type: none"> a) The motor protection switch of the vacuum pump has tripped. b) The vacuum pump is blocked, e.g. after lengthy operating pauses. 	<ol style="list-style-type: none"> a) Switch the steam sterilizer off and then on again. b) A stuck vacuum pump can be released as follows: <ol style="list-style-type: none"> 1. Acknowledge the malfunction message. 2. Switch off the steam sterilizer, disconnect the power plug and open the service hatch. 3. Insert an Allen key (6 mm) into the opening for emergency starting of the vacuum pump as far as it will go until the Allen key engages. Turn the Allen key alternately in both directions to free the blockage of the vacuum pump. Repeat the process until the Allen key can be turned easily. 4. Remove the Allen key. 5. Close the service hatch. Connect the power plug and activate the device.
182	The mains voltage is too low, poor building voltage supply (e.g. under-dimensioned building installation, defective socket, multiple devices connected to a single socket or fuse).	Arrange for an inspection of the building-side installation (e.g. automatic circuit breaker) and test the steam sterilizer at another socket or on another circuit.
183	see event 124	
185	see event 110	
186	see event 132	
187	see event 102	
203	No options have been set for the output of logs.	Check the configuration in the Settings > Logging menu.
204	The internal log memory is full.	Output the log saved in the steam sterilizer on any output medium or adapt the general output options in the Settings > Logging menu.
207	see event 203	
208	see event 204	
211	see event 204	

Event	Possible causes	What you can do
214	The steam sterilizer has not recognised the CF card; it cannot be read, or it is damaged.	<ol style="list-style-type: none"> 1. Check whether the CF card has been inserted correctly (do not insert under voltage). 2. Make sure that the CF card is not larger than 4 GB. 3. Check whether the write-protection has been set on the CF card by mistake. 4. Test the CF card on a computer. 5. Check whether the memory on the CF is full. If the memory is full, transfer the log files on the CF card to a computer and delete the files on the CF card. 6. Transfer the log files on the CF card to a computer and re-format the CF card in the steam sterilizer. 7. The CF card is defective or incompatible. A non-MELAG CF card has possibly been used. <p>PLEASE NOTE: MELAG recommends only using original MELAG CF cards.</p>
215	see event 214	
218	The attempt was made to overwrite a write-protected log with a log of the same name.	<ol style="list-style-type: none"> 1. Transfer the log file the CF card to another computer and delete the file from the CF card. 2. Insert the empty CF card in the card slot and enter the log again.
221	The CF card or a subdirectory of the CF card is full.	<ol style="list-style-type: none"> 1. Transfer the present log files from the CF card to a computer. 2. Format the CF card in the steam sterilizer. 3. Try again.
223	The CF card has not been recognized.	<ol style="list-style-type: none"> 1. Transfer the present log files from the CF card to a computer. 2. Format the CF card in the steam sterilizer. 3. Try again.
224	see event 223	
228	see event 223	
229	The CF card was removed from the slot during a writing/reading action.	Never remove the CF card from the slot whilst it is being written or read. Insert the CF card in the card slot and repeat the procedure.
231	The CF card cannot be located/has not been inserted.	Check whether the CF card has been inserted correctly or insert it in the slot again. Upon repeated incidence, transfer the present log files from the CF card to a computer and format the CF card in the steam sterilizer and then try again.
232	see event 229	
236	File malfunction on the CF card.	<ol style="list-style-type: none"> 1. Transfer the present log files from the CF card to a computer. 2. Format the CF card in the steam sterilizer. 3. Try again.
237	The CF card has not been recognised.	Check whether the CF card is write protected. Disable the write protection. Upon repeated incidence, transfer the present log files from the CF card to a computer and format the CF card in the steam sterilizer and then try again.

Event	Possible causes	What you can do
238	<ul style="list-style-type: none"> a) It is not possible to format the CF card because it is larger than 4 GB. b) The CF card is defective or incompatible. c) The CF card is write-protected. 	<ul style="list-style-type: none"> a) Use only CF cards with a maximum storage capacity of 4 GB. b) 1. Try formatting the CF card on a computer. 2. The CF card is defective or incompatible. It is possible that a non-MELAG CF card has been used. PLEASE NOTE: MELAG recommends using only original MELAG CF cards. c) Disable the write-protection on the CF card.
240	The CF card has not been recognized.	<p>Make sure that the CF card has been inserted in the slot correctly.</p> <p>Upon repeated incidence, transfer the present log files from the CF card to a computer and format the CF card in the steam sterilizer and then try again.</p>
249	The door does not close. The door gasket and/or the seal face is soiled.	Check and clean the door gasket and seal face on the sterilization chamber for soiling, foreign bodies or damage, see Cleaning [▶ page 62].
305	<ul style="list-style-type: none"> a) The connection cable behind the display is loose or has a loose contact. b) The CF card is slow or defective. 	<ul style="list-style-type: none"> a) Remove the display from the mount and check that the connection cable is correctly connected to the display and is undamaged. b) Use a different CF card.
351	The maximum operating interval or the number of batches since initial commissioning or the last maintenance have been reached. Maintenance is necessary.	Schedule a maintenance appointment with an authorised technician. You can continue to operate the steam sterilizer until the maintenance.
353	The steam sterilizer was switched off too early after alteration of the settings.	Always wait until the alterations in the steam sterilizer have been fully accepted before switching off the steam sterilizer. This is indicated in the display by changing into the previous menu or through the start screen.
360	--	Please contact the technical service.
367	The internal malfunction log memory is full.	Ensure that the selected output media are suitable for your instruments and are ready. Working in the Log output menu, output the non-outputted logs.
372	The device's internal memory for program logs is full.	Make sure that the selected output media are connected and ready. Output all logs that have not yet been output in the Log output menu.
377	An attempt was made to output logs via the log printer but a log printer is not connected.	Check whether the log printer has been connected correctly. If you do not wish to output any logs in the log printer, deactivate the log printer as an output medium, see Logging [▶ page 45].
380	see event 377	
386	The internal program log memory is almost full.	Ensure that the selected output media are suitable for your instruments and are ready. Working in the Log output menu, output the non-outputted logs at the next opportunity.
397	<ul style="list-style-type: none"> a) The network cable has been disconnected or is damaged. b) The network cable is not compatible. c) The computer is not switched on. d) The network connection was not configured correctly. e) The documentation software on the computer was not started. 	<ul style="list-style-type: none"> a) Check whether the network cable has been connected correctly or is damaged. b) Check whether a 1:1 network cable has been connected. A 1:1 network cable must be used for the direct connection between steam sterilizer and computer. c) Switch on the computer. d) Check the network settings, see Logging [▶ page 45]. e) Start the documentation software.

Event	Possible causes	What you can do
402	The door is blocked and cannot be closed. a) The door gasket and/or the seal face is soiled and or damaged. b) The load blocks the door area. c) The closing mechanism is stiff.	a) Check the door gasket and seal face on the sterilization chamber for soiling, foreign bodies and damage. b) Check whether the load is blocking the door. c) Check the door spindle and the door lock nut for damage. Clean both and oil the door lock nut with the MELAG oil provided. Use the test gauge to check the door lock nut for wear.
407	see event 83	
408	a) The water inflow tap has not been opened or has been opened only insufficiently. b) The building water pressure is too low or fluctuates. c) The inflow filter is kinked. d) The inflow filter in the Aqua-Stop of the inflow hose or the leakage water detector (if present) is blocked by soiling in the building supply. If a leakage water detector (water stop) is installed: e) The leakage water detector is without function.	a) Open the water inflow tap completely and check whether the central water inflow tap is open. b) Check the pressure of the building water supply. The minimum flow pressure should amount to 1.5 bar at 8 l/min. c) Check the installation of the inflow hose. It must be installed without kinking and may not be crushed. d) Clean the inflow filter in the Aqua Stop of the inflow hose or the leakage water detector valve as follows: 1. Turn off the water inflow tap. 2. Switch off the steam sterilizer. 3. Unscrew the inflow hose or the leakage water detector valve on the water inflow tap and check the inflow filter; clean it if necessary. e) Unplug the leakage water detector control device from the socket, wait approx. 30 s and then plug it back in again. A switching noise on the leakage water valve (black box on the water inflow tap) must be audible.
414	The wastewater cannot flow away. a) The outlet hose is kinked or sags. b) The U-trap or the building-side outlet line is blocked, or multiple devices have been connected to a single U-trap. c) The chamber filters are blocked.	a) Check the installation of the outlet hose. This must be laid free of kinks or sags and with a constant gradient. b) Check whether the building's U-trap is blocked. PLEASE NOTE: If you operate multiple devices at the same time, MELAG recommends installing an additional U-trap. c) Check whether the chamber filters are soiled/ clogged (at the fixing points under the front and rear of the slide rail), e.g. by packaging residues. If necessary, clean the chamber filters.
416	see event 214	
417	see event 397	
428	see event 102	
434	Overheat on temperature sensor 2	1. Switch off the steam sterilizer and allow it to cool for 15 min. 2. Switch on the steam sterilizer. Steam sterilizer is ready to operate again. If this occurs repeatedly, please contact the technical service.
438	The steam sterilizer must be validated.	Arrange for validation of the steam sterilizer.
439	see event 102	
452	An attempt was made to execute actions on the display although the label printer is still printing labels.	Please wait until the label printer has printed all labels. The desired action can then be executed.
457	The date or time was set incorrectly.	Check the date and time settings and correct if necessary, see Date and time [▶ page 56].

Event	Possible causes	What you can do
458	a) The date or time was set incorrectly. b) The start time pre-selection timer has run down but the steam sterilizer was switched off at the time for which the start time was selected.	a) Check the date and time settings and correct if necessary, see Date and time [▶ page 56]. b) The steam sterilizer must be switched on at time for which the start time is selected.
464	An attempt was made to execute actions on the display although the log printer is still printing.	Please wait until the log printer has printed the log(s) completely. The desired action can then be executed.
465	a) The connection to the label printer has been interrupted. b) The label printer has not been switched on.	a) Check whether the power cable is connected to the socket and the Ethernet cable of the label printer is correctly connected with the steam sterilizer. b) Switch on the label printer. The power LED must illuminate green.
479	see event 397	
486	see event 82	
488	see event 457	
489	see event 136	
490	see event 136	
491	see event 136	
492	see event 136	
493	see event 136	
495	see event 408	
496	see event 408	
499	a) The shut-off valve of the MELAdem 56/56 M pressure tank is closed. b) Insufficient pressure in the pressure tank of the MELAdem 56/56 M (< 1 bar). c) Leak or kinked hoses in the feed water supply. d) The supply from an external feed water supply has been interrupted / the flow pressure is too low (e.g. central water treatment). e) Insufficient flow pressure on the cold water inflow of the MELAdem 56/56M. f) The water supply on the steam sterilizer is set to a pressureless water treatment unit, but a pressurized unit e.g. MELAdem 56/56 M, has been connected.	a) Connect the shut-off valve of the MELAdem 56/56 M pressure tank. b) Check the pressure on the manometer of the MELAdem 56/56 M. If the pressure is under 1 bar, leave the steam sterilizer activated until the pressure in the pressure tank has risen over 1 bar. The pressure pump of the MELAdem 56/56 M must function audibly. Do not switch off the steam sterilizer immediately after sterilization; leave it switched on for approx. 30 min. c) Check all the hoses of the feed water supply from the MELAdem 56/56 M to the steam sterilizer for leaks and kinks. d) 1. Check whether all the taps of the house water supply in the feed water line are open. 2. Check the flow pressure (min. 1 bar). e) Check the flow pressure of the house water supply using a flow pressure gauge (min. 0.5 bar at 5 l/min). f) If a MELAdem 56/56 M or another pressurized device is connected, check whether in the menu Settings > Device settings > Water supply the option YES has been selected.
500	see event 499	
543	a) The outlet hose is kinked, blocked or has insufficient tension. b) The outlet line is blocked. c) Multiple devices have been connected to a single siphon.	a) Check the installation of the outlet hose. It must be installed without kinking and may not be crushed. Depending on the device type and its position, the outlet hose must be stretched taught below the floor trough using a tensioning carriage. b) Check whether the building siphon is blocked. c) If multiple devices are operated simultaneously, we recommend the installation of an additional siphon.

Event	Possible causes	What you can do
545	a) The building fuse via residual current device has tripped. b) The power plug has been disconnected or has not been connected correctly in the socket. c) Malfunction in the electrical installation.	a) Switch the residual current device back on or replace it if necessary. b) Check whether the power plug is connected, the power cable has suffered damage, or a loose contact or loose plug connections is the cause. Plug the power plug back into the mains socket. c) Arrange for an inspection of the building-side installation (e.g. automatic circuit breaker) and test the steam sterilizer at another socket or on another circuit.
546	a) The building fuse L1 has tripped. b) The power plug has been disconnected or has not been connected correctly in the socket. c) Malfunction in the electrical installation.	a) Switch the fuse L1 back on or replace it if necessary. b) Check whether the power plug is connected, the power cable has suffered damage, or a loose contact or loose plug connections is the cause. Plug the power plug back into the mains socket. c) Arrange for an inspection of the building-side installation (e.g. automatic circuit breaker) and test the steam sterilizer at another socket or on another circuit.
547	a) The building fuse L2 has tripped. b) The power plug has been disconnected or has not been connected correctly in the socket. c) Malfunction in the electrical installation.	a) Switch the fuse L2 back on or replace it if necessary. b) Check whether the power plug is connected, the power cable has suffered damage, or a loose contact or loose plug connections is the cause. Plug the power plug back into the mains socket. c) Arrange for an inspection of the building-side installation (e.g. automatic circuit breaker) and test the steam sterilizer at another socket or on another circuit.
548	a) The building fuse L3 has tripped. b) The power plug has been disconnected or has not been connected correctly in the socket. c) Malfunction in the electrical installation.	a) Switch the fuse L3 back on or replace it if necessary. b) Check whether the power plug is connected, the power cable has suffered damage, or a loose contact or loose plug connections is the cause. Plug the power plug back into the mains socket. c) Arrange for an inspection of the building-side installation (e.g. automatic circuit breaker) and test the steam sterilizer at another socket or on another circuit.
549	a) The vacuum pump motor protection switch has tripped. b) The vacuum pump has suffered a blockage e.g. following long shutdown periods.	a) Switch off steam sterilizer and switch on again. Then the steam sterilizer is ready for operation. b) A vacuum pump can be unblocked in the following fashion: 1. Acknowledge the malfunction message. 2. Switch off the steam sterilizer, disconnect the power plug and open the service hatch. 3. Insert a 6 mm Allen key into the opening to its fullest extent to effect an emergency turning of the vacuum pump. Insert until the key takes a grip and then turn it in both directions to free the blockage of the vacuum pump. Repeat until the screw driver can be turned easily. 4. Then remove the key again. 5. Close the service hatch, connect the power plug and switch on the device. Then the steam sterilizer is ready for operation.

Event	Possible causes	What you can do
553	The vacuum pump has suffered a blockage e.g. following long shutdown periods.	A vacuum pump can be unblocked in the following fashion: 1. Acknowledge the malfunction message. 2. Switch off the steam sterilizer, disconnect the power plug and open the service hatch. 3. Insert a 6 mm Allen key into the opening to its fullest extent to effect an emergency turning of the vacuum pump. Insert until the key takes a grip and then turn it in both directions to free the blockage of the vacuum pump. Repeat until the Allen key can be turned easily. 4 Then remove the key again. 5. Close the service hatch, connect the power plug and switch on the device. The steam sterilizer is now ready for operation. Should this repeat, please contact the service technician.
576	see event 546	
577	see event 547	
578	see event 548	
579	see event 546	
580	see event 547	
581	see event 548	
589	see event 136	
590	see event 136	
591	see event 136	
593	see event 136	
594	a) The chamber fittings (pressure plate) in the sterilization chamber are soiled or covered. b) The condensate guard is slipped.	a) Check the sterilization chamber interior for packaging or soiling. The load should have no contact with the sterilization chamber. b) Check the position of the condensate guard in the sterilization chamber and correct the alignment. The condensate guard must sit directly below the temperature sensors.
595	see event 594	
596	see event 594	
597	see event 594	
598	see event 594	
599	see event 594	
629	An unpermitted feed water flow was detected.	Switch off the device and switch on again.
635	The label printer was selected as an output medium, but a label printer could not be located.	Check the configuration in the menu Settings > Label printer .
637	Label printer label roll exhausted.	Insert a new label roll in the label printer.
638	Label printer cover is open.	Close the label printer cover.
645	The log printer was selected as an output medium, but a label printer could not be located.	Check the configuration of the log printer in the menu Settings > Log printer .
646	a) The user name or password for log-in to the FTP server is incorrect. b) The user name or password for log-in to the FTP server has not been setup correctly.	a) Check whether the user name and password set on the steam sterilizer corresponds wit those set on the FTP server, see Settings [▶ page 45]. b) Check the FTP server settings and the connection to the steam sterilizer.
648	see event 646	

Event	Possible causes	What you can do
651	<p>a) The door on the removal side was not pushed closed for long enough with sufficient force; as a result, the thread has become caught.</p> <p>b) The door spindle and/or the door lock nut (removal side) have not been greased regularly and are dry.</p>	<p>a) Close and hold the door with force for approx. 3 s until the spindle engages in the door lock and the door is pulled in automatically. A motor sound is audible.</p> <p>b) Grease the door spindle and the door lock nut regularly with the grease included in the scope of delivery, see Maintenance [▶ page 62].</p>
652	<p>a) There are objects in the area of the door on the removal side.</p> <p>b) There is still a residual vacuum in the sterilization chamber. Pressure equalisation has not yet been completed.</p> <p>c) The door gasket (removal side) sticks to the seal face of the sterilization chamber.</p>	<p>a) Always keep the area in front of the door free so that it can open unhindered.</p> <p>b) 1. Wait 2 min, and then acknowledge the message with OK. 2. If the door does not open by itself, switch off the steam sterilizer, wait for 5 min and then switch it back on. Try again to open the door. If the door then still doesn't open, please contact the technical service.</p> <p>c) If it was possible to open the door, clean the door gasket and the seal face in the sterilization chamber, see Maintenance [▶ page 62].</p>
653	<p>The door on the removal side does not reach a pressure-tight state after the program start.</p> <p>a) The door gasket and/or the seal face (removal side) is soiled and or damaged.</p> <p>b) The load blocks the closing sequence.</p> <p>c) The closing mechanism (removal side) is stiff.</p>	<p>a) Check the door gasket and the seal face in the sterilization chamber for soiling, foreign bodies or damage.</p> <p>b) Check whether the load is blocking the door.</p> <p>c) Check the door spindle and the door lock nut for damage. Clean and grease the door spindle and the door lock nut with the grease included in the scope of delivery.</p>
654	see event 653	
655	see event 652	
690	The display has been pulled off and replaced if necessary.	Replace the displays from the loading and removal side.
692	see event 132	
693	see event 132	
694	see event 132	
900	System state is incorrect.	Switch the device off and then on again.

14 Technical data

Device type	Cliniclave 45 D	Cliniclave 45 MD
Device dimensions (H x W x D)	158 x 64 x 101 cm	158 x 64 x 163 cm
Empty weight	298 kg 316 kg inc. MELAdem 56	384 kg 409 kg inc. MELAdem 56 M
Operating weight	335 kg 373 kg inc. MELAdem 56 ¹⁾	435 kg 488 kg inc. MELAdem 56 M ²⁾
Floor loading (pressure resistance test)	465 kg 116.3 kg per caster ³⁾	675 kg 168.8 kg per caster ⁴⁾
Working pressure	max. 2.7 bar	
Permissible working pressure	2.2 bar	
Permissible working temperature	136 °C	
Sterilization chamber		
Diameter	44 cm	
Depth	74 cm	136 cm
Usable chamber space	1 StU	2 StU
Volume	110 l	205 l
Electrical connection		
Power supply (star connection)	3x380-415 V + N + PE, 16 A, 50/60 Hz	3x380-415 V + N + PE, 32 A, 50/60 Hz
Power supply (delta connection)	3x220-240 V + PE, 32 A, 50/60 Hz	3x220-240 V + PE, 63 A, 50/60 Hz
Electrical power	10.5 kW	13.5 kW
Building-side fuse protection (star connection)	3x16 A, RCD 30 mA	3x32 A, RCD 30 mA
Building fuses (delta connection)	3x32 A, RCD 30 mA	3x63 A, RCD 30 mA
Degree of contamination (in accordance with EN 61010-1)	2	
Overvoltage category (in accordance with EN 61010-1)	II	
Length of the power cable from the floor unit	max. 1.6-1.9 m (depending on the connection side)	max. 1.8-2.1 m (depending on the connection side)
Ambient conditions		
Installation location	interior of a building	
Noise emission	max. 72 dB(A)	
Heat emission (at maximum solid load and with an opened door)	1.4 kW	2.0 kW
Ambient temperature	5-40 °C (ideal range 16-26 °C)	5-40 °C (ideal range 16-26 °C)
Degree of protection (in accordance with IEC 60529)	IP20	
Relative humidity	max. 80 % at temperatures of up to 31 °C, max. 50 % at 40 °C (decreasing in linear fashion in-between)	
Altitude (star connection)	max. 3000 m	
Altitude (delta connection)	max. 4000 m	
Cold water connection		
Min. flow pressure	1.5 bar at 8 l/min	
Max. water consumption	8 l/min	
Max. static water pressure	10 bar	
Water quality	drinking water, water hardness 4-12° dH (in accordance with EN 285)	
Water temperature	1-20 °C (ideal 15 °C)	

¹⁾ This applies to an operational device filled with water and, depending on the load, can increase by up to 40 kg.

²⁾ This applies to an operational device filled with water and, depending on the load, can increase by up to 80 kg.

³⁾ When using MELAdem 56, an additional weight of 33 kg (8.25 kg per caster) must be taken into account.

⁴⁾ When using a MELAdem 56 M, an additional weight of 42 kg (10.5 kg per caster) must be taken into account.

Device type	Cliniclave 45 D	Cliniclave 45 MD
Feed water connection		
Min. flow pressure	0.5 bar at 5 l/min	
Max. water consumption	5 l/min	
Max. static water pressure	5 bar	
Water quality	EN 285, Appendix B, table B.1	
Water temperature	5-35 °C	
Wastewater connection		
Max. throughflow volume	short-term max. 9 l/min	
Water temperature	short-term max. 90 °C	

15 Accessories and spare parts

You can obtain the specified articles and an overview of further accessories from your stockist.

Category	Article	Art. no.	
		Cliniclave 45 D	Cliniclave 45 MD
Mounts	Mount for 2 instrument baskets (1/2 StM) or 4 trays (1/4 StM), 31 x 58 x 28 cm	ME04522	
Package holder	Package holder, short, 18.4 x 28 x 8.5 cm	ME22410	
	Package holder, , long, 18.4 x 37 x 8.5 cm	ME22420	
Films	MELAfol 501 (pouch, 5 x 25 cm, 1000 pcs.)	ME00501	
	MELAfol 502 (roll, 5 cm x 200 m)	ME00502	
	MELAfol 751 (pouch, 7.5 x 25 cm, 1000 pcs.)	ME00751	
	MELAfol 752 (roll, 7.5 cm x 200 m)	ME00752	
	MELAfol 1001 (pouch, 10 x 25 cm, 1000 pcs.)	ME01001	
	MELAfol 1002 (roll, 10 cm x 200 m)	ME01002	
	MELAfol 1502 (roll, 15 cm x 200 m)	ME01502	
	MELAfol 2002 (roll, 20 cm x 200 m)	ME02002	
	MELAfol 2051 (side gusset bag, 20 x 50 cm, 100 pcs.)	ME02051	
Instrument baskets and trays	Tray large (1/4 StM), 31 x 58 x 5 cm	ME04520	
	Instrument basket (1/2 StM), 57 x 28 x 13 cm	ME00260	
MELAstore systems	MELAstore Box 100, 31.2 x 19 x 4.6 cm	ME01191	
	MELAstore Box 200, 31.2 x 19 x 6.5 cm	ME01192	
Loading systems	Loading trolley	ME01145	
	Slide rail Comfort	ME85920	ME85930
	Batch slider	ME04521	
	Loading hook	ME28887	
Test body systems	MELAcontrol Helix	ME01082	
	MELAcontrol Pro (incl. 40 indicator strips)	ME01075	
	MELAcontrol Bowie & Dick test (1 pc.)	ME01078	
Water treatment	MELAdem 56 reverse osmosis unit	ME11056	--
	MELAdem 56 M reverse osmosis unit	--	ME11057
Documentation	CF card	ME01043	
	Card reader for CF card	ME01048	
	MELAtrace documentation software	ME21138	
	MELAprint 60 label printer	ME01160	
	Network cable, 2.5 m	ME15817	
	Network cable, 5 m	ME15814	
	MELAprint 44 log printer	ME01144	
Network adapter for MELAprint	ME40295		

Category	Article	Art. no.
Other	Water stop (leakage water detector with shut-off valve and probe)	ME01056
	Surface-mounted siphon	ME37410
	Installation set	ME09027
	Carrying bar set (short) for Cliniclave 45/45 D	ME82821
	Carrying bar set (long) for Cliniclave 45 M/45 MD	ME82820
	MELAG Care Oil Spray	ME22935
	Heat protection gloves	ME89600
Spare parts	Door seal for Cliniclave 45/45 M/45 D/45 MD	ME60480
	MELAG oil for door lock nut	ME27515
	Test gauge TR20 for door lock nut	ME27521

Glossary

Accessory

Accessories are independent articles that are used with one or several medical devices. Accessories specifically and directly assist the intended purpose of the medical device.

AKI

AKI is the abbreviation for "Arbeitskreis Instrumentenaufbereitung" [Instrument Reprocessing Working Group].

Authorised technician

An authorised technician is a person intensively trained and authorised by MELAG who has sufficient specific device and technical knowledge, to perform maintenance and installation work on MELAG devices. Only they may carry out this work.

Batch

The batch is the composition of items which has been subject to the same reprocessing procedure.

BfArM

BfArM is the abbreviation for "Bundesinstitut für Arzneimittel und Medizinprodukte" [Federal Institute for Drugs and Medical Devices] in Germany.

Bowie & Dick test

The Bowie & Dick test is a vapour penetration test with standard test package, see EN 285. This test is recognised in large-scale sterilization.

CF card

The CF card is a memory medium for digital data; Compact Flash is an official standard, i.e. these memory cards can be used in every device fitted with the corresponding slot. The CF card can be read by every device that supports the standard and where necessary, written on.

Competent personnel

Trained personnel in accordance with national specifications for the respective area of application (dentistry, medicine, podiatry, veterinary medicine, cosmetics, piercing, tattoo) with the following contents: knowledge of instruments, hygiene and microbiology, risk assessment and classification of medical devices and instrument reprocessing.

Component

A component is a part of a medical device, which is delivered with it but is not permanently connected to it. A component supports or achieves the intended purpose of the medical device for at least one use case. It is not an independent accessory or medical device.

Condensate

Condensate is a liquid (e.g. water) that emerges from the vapour state when cooled and thus separates.

Conductivity

Conductivity is the ability of a conductive chemical substance or mixture of substances to conduct or transfer energy or other substances or particles in space.

Corrosion

Corrosion is the chemical alteration or destruction of metallic materials by water and chemical substances.

Delay in boiling

Superheating is the phenomenon that it is possible under certain circumstances to heat liquids beyond their boiling point without them boiling. This condition is unstable. Low-level agitation can produce a large bubble within the shortest period; this can expand explosively.

Demineralised water

Demineralised water does not contain minerals that are found in normal spring or tap water. It is obtained from tap water by ion exchange and used as feed water.

DGSV

DGSV is the abbreviation for "Deutsche Gesellschaft für Sterilgutversorgung" [German Society for Sterile Supply]. The training guidelines of the DGSV are listed in DIN 58946, Part 6 as requirements for personnel.

DGUV Regulation 1

DGUV is the abbreviation for "Deutsche Gesetzliche Unfallversicherung" [German Statutory Accident Insurance]. The regulation 1 governs the principles of prevention.

DIN 58946-7

Standard for "Sterilization – Steam sterilizers – Part 7: Building requirements and requirements placed on the equipment and the operation of steam sterilizers in the health-care branch"

DIN 58953

Standard for "Sterilization – Sterile supply"

Distilled water

Distilled water is largely free of salts, organic substances, and micro-organisms. It is obtained by distillation (evaporation and subsequent condensation) from normal tap water or pre-purified water. Distilled water is used as feed water.

Double jacket steam generator

The double jacket steam generator is used for rapid steam generation outside the sterilization chamber and ensures uniform temperature distribution in the chamber wall.

EN 1717

Standard for "Protection against pollution of potable water installations and general requirements of devices to prevent pollution by back flow"

EN 285

Standard for “Sterilization – Steam sterilization – Large sterilizers”

EN ISO 11140-1

Standard for “sterilization of products for use in medical treatment – chemical indicators – part 1: General requirements”

EN ISO 11607-1

Standard for “packaging for medical devices to be sterilized in the final packaging – Part 1: Requirements placed on materials, sterile barrier systems, and packaging systems”

EN ISO 17665

Standard for “Sterilization of health care products — Moist heat — Requirements for the development, validation and routine control of a sterilization process for medical devices“

Equipment

Equipment is an article that can be used with the medical device, however, it is not necessary for assisting and/or achieving the intended purpose of the medical device. It is not an independent accessory or medical device.

Evacuation

Evacuation is the creation of a vacuum in a vessel.

Feed water

Feed water is required to generate the water vapour for sterilization; guide values for water quality in accordance with EN 285 or EN 13060 – Appendix C.

Fractionated vacuum procedure

The fractionated vacuum process is a technical process of steam sterilization. This procedure includes the repeated evacuation of the sterilization chamber in alternation with steam injection.

FTP

FTP (File Transfer Protocol) is a data transmission procedure serving to transfer data from the Internet. This data can include programs, files or even information. Special FTP programs (FTP clients) serve to load the data onto a server.

KRINKO

KRINKO is the abbreviation for “Kommission für Krankenhaushygiene und Infektionsprävention” [Commission for Hospital Hygiene and Infection Prevention] at the Robert Koch Institute in Germany.

Load

The load includes products, equipment, or materials that are reprocessed together in one operating cycle.

Medical device

Medical device means any instrument, apparatus, appliance, software, implant, reagent, material or other article intended by the manufacturer to be used, alone or in combination, for human beings for one or more of the

specific medical purposes in accordance with Regulation (EU) 2017/745 Article 1, Paragraph 4.

Mixed loads

The load within a batch includes both packed and unpacked products.

Multiple wrapping

The load is sealed in a double layer of film, instruments wrapped in foil are additionally planed in a container or containers wrapped in textiles.

Porous

Porous describes the property of materials (e.g. textiles) to allow water, air, or other liquids to pass through.

Pre-heating time

The preheating time is the time required for preheating the double-jacket steam generator after starting up the device or after starting a reprocessing program before the sterilization process starts. The duration depends on the sterilization temperature.

Process evaluation system

The process evaluation system (also known as “self-monitoring system”) monitors itself and compares sensors during running programs.

Qualified electrician

The qualified electrician has the suitable technical training, knowledge, and experience to recognise and avoid hazards that can be caused by electricity, see IEC 60050 or for Germany VDE 0105-100.

Reprocessing

Reprocessing is a measure to prepare a new or used healthcare device for its intended purpose. Reprocessing includes cleaning, disinfection, sterilization and similar procedures.

RKI

RKI is the abbreviation for “Robert Koch-Institut” [Robert Koch Institute]. The Robert Koch Institute is the central institution for the detection, prevention, and control of diseases, especially infectious diseases.

Soft sterilization packaging

A soft sterilization wrapping is a paper bag or a transparent sterilization package.

Sterile barrier system

The sterile barrier system is a minimum level of sealed packaging that prevents the entry of micro-organisms (e.g. sealed pouches, sealed reusable containers, folded sterilization wipes) and allows for the aseptic delivery of the product at the point of use.

Sterile material

Sterile goods are successfully sterilized (i.e. sterile) goods. Sterile goods are also referred to as batches.

Sterilization chamber

The sterilization chamber is the part of the steam sterilizer where the load is sterilized.

Sterilization module

A sterilization module (StM) is a unit of volume for sterilization in steam sterilizers. It is a cuboid with dimensions 300 mm (height) × 600 mm (length) × 300 mm (width), which equals a total volume of 54 litres.

TCP

TCP (Transmission Control Protocol) designates a standard-protocol for a connection between computers and networks.

Vacuum

Colloquially, vacuum is a space free of matter. In the technical sense, it is a volume with reduced gas pressure (mostly air pressure).



MELAG Medizintechnik GmbH & Co. KG

Geneststr. 6-10

D-10829 Berlin

Germany

Email: info@melag.com

Web: www.melag.com

Original instructions

Responsible for content: MELAG Medizintechnik GmbH & Co. KG

We reserve the right to technical alterations