

User manual

MELAtherm[®] 20 activeDRY

Washer-disinfector

REF ME20022A50T

from software version 6.0.0



EN

Dear customer,

We thank you for your confidence demonstrated by the purchase of this MELAG product. As an owner-run and operated family concern founded in 1951, we have a long history of successful specialization in hygiene products for practice-based use. Our focus on innovation, quality and the highest standards of operational reliability has established MELAG as the world's leading manufacturer in the instrument reprocessing and hygiene field.

You, our customer are justified in your demand for the best products, quality and reliability. Providing **“competence in hygiene”** and **“Quality – made in Germany”**, we guarantee that these demands will be met. Our certified quality management system is subject to close monitoring: one instrument to this end is our annual multi-day audit conducted in accordance with EN ISO 13485. This guarantees that all MELAG products are manufactured and tested in accordance with strict quality criteria.

The MELAG management and team.

CE 0197

Contents

| | | | |
|---|-----------|--|-----------|
| 1 General guidelines | 6 | Inserting the central filter | 31 |
| Symbols used | 6 | Checking connection points | 32 |
| Formatting rules | 6 | Adjusting the levels of the basis baskets | 32 |
| Disposal | 6 | Commissioning | 33 |
| 2 Safety | 7 | Service menu | 33 |
| 3 Performance specifications | 8 | Logging in/out as a service technician | 34 |
| Intended use | 8 | Checking the software version | 34 |
| Performance features | 8 | Determining and adjusting the water hardness | 35 |
| Program sequence | 9 | Filling the regenerating salt and regenerating the water softening unit | 35 |
| Process agents | 9 | Basic settings | 35 |
| 4 Description of the device | 11 | Checking the metering concentration | 36 |
| Scope of delivery | 11 | Exceptions when setting up at altitudes | 36 |
| Views of the device | 12 | De-aerating the metering system | 37 |
| Symbols on the device | 13 | Checking the metering accuracy | 37 |
| Operating panel | 15 | Determining the feed rates/calibration of the metering pumps | 39 |
| Buttons and icons in the information area | 15 | Process-relevant parameters | 41 |
| LED Status bar and acoustic signals | 16 | Trial run | 44 |
| Favourites menu | 17 | Resetting the maintenance counter | 44 |
| Menu structure | 18 | Validation | 44 |
| Water softening unit | 19 | Magnetic pocket for device logbook | 44 |
| 5 Installation requirements | 20 | Allen key for door emergency opening | 44 |
| Installation location | 20 | Instructing the users | 45 |
| Electromagnetic environments | 20 | 7 First steps | 46 |
| Setup variants | 20 | Water supply | 46 |
| Connection diagram | 21 | Starting up and shutting down the device | 46 |
| Space requirements | 22 | Opening and closing the door | 47 |
| Additional space requirements | 22 | Automatic door opening | 47 |
| On-site requirements | 23 | Manual door opening | 48 |
| Mains connection | 23 | Closing the door | 48 |
| Water connection | 23 | Inserting the basis baskets into the washing chamber .. | 48 |
| System and network safety | 24 | Filling the regenerating salt | 49 |
| 6 Setup and installation | 26 | Regenerating the water softening unit | 51 |
| Record of installation | 26 | Metering process agents | 51 |
| Removing from the packaging | 26 | Holding process agents ready | 51 |
| Connecting the inlet hoses and outlet hose | 27 | Containers for process agents | 52 |
| Installing the metering system | 28 | MediaGuard Box | 52 |
| Process agent container | 28 | Product change | 53 |
| Setting up the MediaGuard Box | 28 | De-aerating the metering system | 54 |
| Metering system interface | 29 | Air removal program options | 54 |
| Fitting the anti-tilt device | 30 | 8 Components for reprocessing | 56 |
| Positioning and aligning the device | 30 | Use of tools | 56 |
| Starting up the device and opening the door | 31 | Disposal | 56 |
| Fitting the stainless steel cover plate | 31 | Basis baskets | 56 |

| | | | |
|---|----|--|------------|
| Holders..... | 57 | Adapter for turbines with KaVo connector (MULTIflex)..... | 98 |
| Universal holder Flex 1-4 | 57 | Adapter for EMS AIR-FLOW Handy 3.0..... | 98 |
| Universal holder Flex 1-4 (low)..... | 58 | Adapter for EMS AIR-FLOW Prophylaxis Master..... | 99 |
| Holder for trays (5 pcs.)/half trays (10 pcs.)..... | 59 | Adapter for NSK Prophy Mate Neo (airflow) | 99 |
| Instrument baskets..... | 60 | Adapter for NSK Varios Combi Pro (airflow) | 100 |
| Instrument basket G, compact and standard..... | 60 | Adapter for MyLunos powder water jet nozzle | 100 |
| Tip protection for instrument basket..... | 61 | Adapter for Sirona Sprayvit nozzle..... | 101 |
| Small parts basket..... | 61 | Adapter for KaVo multifunctional cannula | 101 |
| Small parts basket Standard..... | 62 | Filter disc housing incl. ceramic filter disc | 102 |
| Komfort small parts basket | 62 | Universal adapter incl. 3 inserts and ceramic filter disc..... | 103 |
| Bur holder | 63 | Instrument holder for universal adapter..... | 104 |
| Stackable holders and baskets | 64 | Distance sleeve | 104 |
| Flex basket 1-4 | 65 | Adapter for external spray channels..... | 105 |
| Flex basket 6..... | 65 | Distributor | 106 |
| Flex basket 8..... | 66 | Triple distributor..... | 106 |
| Flex basket specula | 66 | Triple distributor (incl. ceramic filter disc)..... | 107 |
| Flex supplementary basket..... | 68 | Injector basket Flex 1 | 108 |
| Holder for hinged instruments and impression trays... | 68 | Filter inserts | 109 |
| Instrument holder for Flex baskets..... | 69 | Central filter | 109 |
| Top frames for stackable baskets (Flex system)..... | 69 | Ceramic filter disc..... | 109 |
| Top frame for ear specula Flex 1-3..... | 70 | Metal filter disc | 110 |
| Top frame for nasal specula Flex 1 incl. 2 fixing clamps..... | 70 | Closure elements..... | 111 |
| Fixing clamps for top frame..... | 71 | Silicone closure caps..... | 111 |
| MELAstore Tray and silicone bars | 71 | Screw plug for injector rail and distributors | 112 |
| MELAstore Tray 33, 50, 100 and 200..... | 72 | Closure (male) for Luer-Lock..... | 112 |
| MELAstore Tray Ophthalmology..... | 72 | Closure (female) for Luer/Luer-Lock | 113 |
| MELAstore Tray Ophthalmology light | 79 | Hoses and hose connections | 113 |
| Silicone bars | 85 | Hose connector (6 mm) with external thread | 114 |
| Injector rail module..... | 85 | Hose connector (6 mm) with internal thread | 114 |
| Connectors and adapters for instruments..... | 86 | Silicone hose without/with connections | 115 |
| Injector nozzle..... | 87 | DIN sieve trolley | 115 |
| Clamp spring for injector nozzle..... | 88 | 9 Loading the device | 117 |
| Rinse sleeve incl. 5 inserts | 88 | Principles of the load configuration..... | 117 |
| Adapters for Luer and Luer-Lock | 89 | The 8-segment principle..... | 117 |
| Adapter (male) for Luer-Lock..... | 90 | The Flex system | 118 |
| Adapters for tips and ultrasonic handpieces | 91 | Examples for the basic configuration..... | 118 |
| Marking discs for adapters..... | 92 | Loading instructions..... | 121 |
| Adapters for transmission instruments..... | 93 | Type of load..... | 121 |
| Adapter for ISO connector (INTRA)..... | 95 | 10 Cleaning and disinfection | 122 |
| Adapter for turbines NSK connector (Phatelus)..... | 95 | Instructions for reprocessing and use..... | 122 |
| Adapter for Sirona T1 Classic..... | 96 | Routine check after reprocessing..... | 122 |
| Adapter for contra angle heads KaVo/BienAir | 96 | Optimising the cleaning performance | 123 |
| Adapter for turbines with W&H connector (Roto Quick)..... | 97 | Wet/dry storage | 123 |
| Adapter for turbines with Sirona connector..... | 97 | Preparation and pre-cleaning | 123 |





| | | | |
|--|------------|---|------------|
| Process agents | 123 | Drying | 149 |
| Arranging the load..... | 124 | Drying mode and duration | 150 |
| Reprocessing hollow-body instruments | 124 | Door opening..... | 151 |
| Reprocessing dental transmission instruments..... | 125 | 14 Administrative settings | 152 |
| Reprocessing ophthalmological instruments..... | 125 | Logging in/out as the administrator | 152 |
| Selecting the program | 126 | Users | 153 |
| Starting and monitoring the program..... | 127 | Creating users | 153 |
| Prematurely ending or cancelling the program | 129 | Editing a user | 154 |
| Ending the program prematurely | 130 | Delete user | 155 |
| Cancelling a program..... | 130 | Authentication..... | 156 |
| Program result..... | 130 | Approval | 156 |
| Confirming the program result | 131 | Changing the administrator PIN | 156 |
| Removing the load and approving the batch..... | 131 | Favorites | 157 |
| The approval process | 132 | Software update | 158 |
| 11 Logging | 133 | 15 Maintenance | 159 |
| Batch documentation | 133 | Maintenance intervals..... | 159 |
| Output media..... | 133 | Regular checking and cleaning | 160 |
| Finding the logs..... | 134 | Check in the washing chamber | 160 |
| Displaying logs on the computer..... | 134 | Checking the door gasket..... | 162 |
| Logs menu | 134 | Checking the sealing bushes | 162 |
| List of logs..... | 135 | Checking the air filter of the E-Box..... | 163 |
| Outputting logs manually..... | 135 | Checking the components for the reprocessing | 163 |
| Outputting program logs or malfunction logs | 135 | Cleaning on demand | 163 |
| Outputting status log or system log..... | 137 | Avoiding staining | 164 |
| Outputting all logs | 137 | Replacing the HEPA filter of the drying fan | 164 |
| Outputting logs automatically | 137 | Maintenance | 165 |
| 12 Function checks | 138 | (Process) Validation | 165 |
| Automatic and manual function check | 138 | 16 Pause times | 166 |
| Measuring conductivity..... | 138 | Duration of the operating pauses | 166 |
| 13 General settings | 139 | Decommissioning | 166 |
| Menu settings..... | 139 | Storage and transport..... | 167 |
| Language | 139 | Storage of components and spare parts | 167 |
| Date and time..... | 140 | 17 Malfunctions..... | 168 |
| Display brightness | 141 | Displaying and reading messages..... | 168 |
| Volume | 141 | Malfunction logs..... | 169 |
| Program options..... | 141 | Warnings | 170 |
| Log output | 142 | Malfunction messages..... | 172 |
| MELAt race | 142 | Manual door emergency opening | 176 |
| FTP server | 144 | Rinse arms magnet holders..... | 177 |
| USB stick | 146 | 18 Technical data..... | 178 |
| Network..... | 147 | 19 Components, accessories and spare parts | 180 |
| Water..... | 148 | Glossary | 185 |
| DI connection water supply..... | 148 | | |
| Water hardness..... | 149 | | |

1 General guidelines



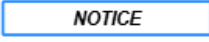
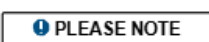

Please read this user manual carefully before commissioning the device. The manual includes important safety instructions. Make sure that you always have access to digital or printed version of the user manual.

Should the manual no longer be legible, is damaged or has been lost, you can download a new copy from MELAG download centre at www.melag.com.

Symbols used

| Symbol | Description |
|---|--|
|  | Indicates a dangerous situation, which if not avoided, could entail slight to life-threatening injuries. |
|  | Indicates a dangerous situation, which if not avoided, could entail slight to moderate injuries. |
|  | Indicates a dangerous situation, which if not avoided, could result in damage to the instruments, the practice fittings or the device. |
|  | Draws your attention to important information. |
|  | Indicates the section in the document that contains content relevant for the service technician. |

Formatting rules

| Example | Description |
|---|---|
|  | Words or phrases appearing on the display of the device are marked as display text. |
|  | Prerequisites for the following handling instruction. |
|  | Reference to the glossary or another text section. |
|  | Information for safe handling. |

Disposal

MELAG devices are synonymous with long-term quality. When you eventually need to decommission your MELAG device, the required disposal of the device can be carried out by MELAG in Berlin. Simply contact your stockist.

Dispose of ▶components, spare parts, ▶accessories, ▶equipment and consumables that you no longer need properly. Comply with all relevant disposal regulations regarding potentially contaminated waste.

The packaging protects the device against transport damage. The packaging materials have been selected for their environmentally-friendly and recycling properties and can be recycled. Returning the packaging to the material cycle reduces the amount of waste and saves raw materials.

Dispose of waste from process agents in accordance with the specifications in the safety data sheet. Information regarding this topic is provided in the safety data sheets or can be obtained directly from the manufacturer of the process agents.

MELAG draws the operator's attention to the fact that they are responsible for deleting personal data on the device to be disposed of.

MELAG draws the operator's attention to the fact that they may be legally obliged (e.g. in Germany according to ElektroG) to remove used batteries and accumulators non-destructively before handing over the device, provided they are not enclosed in the device.

2 Safety



When operating the device, comply with the following safety instructions as well as those contained in the individual chapters. Use the device only for the purpose specified in this manual. Failure to comply with the safety instructions can result in injury and/or damage to the device.

Qualified personnel

- The instrument reprocessing using this washer-disinfector may only be carried out by ►[competent personnel](#).
- The operator must ensure that the users are regularly trained in the operation and safe handling of the device.

Installation

- The device should only be setup, installed and commissioned by MELAG authorised persons.
- Have the electrical connection and the water supply and waste water connections installed only by trained personnel.

Power cable and power plug

- Comply with all legal requirements and locally-specified connection conditions.
- Never operate the device if the plug or power cable are damaged.
- The power cable or plug should only be replaced by ►[authorised technicians](#).
- Never damage or alter the power plug or cable.
- Never bend or twist the power cable excessively.
- Never unplug by pulling on the power cable. Always take a grip on the plug.
- Never place any heavy objects on the power cable.
- Ensure that the power cable does not become jammed in.
- Never lead the cable along a source of heat.
- Never fix the power cable with sharp objects.
- The mains socket must be freely accessible after installation so that the device can be disconnected from the electrical mains at any time if necessary by pulling the mains plug.

Normal operation

- The outlet hose at the back of the device can heat up to 93 °C during operation and remain hot for an extended period after switching off.

Personal protective equipment

- For your own safety and to avoid injuries, always wear personal protective equipment (PPE) or other suitable hand protection when loading and unloading instrument baskets and washing baskets.
- Take care when arranging sharp and pointed instruments and do so in a manner that prevents all danger of injury. Loading should best be performed from back to front and unloading from front to back. Wear suitable protective gloves.
- Wear suitable hand protection when replacing filter elements in order to avoid contamination from soiled surfaces (e.g. by using a cleaning brush).
- When spraying the instruments with the MELAjet spray pistol, make sure that the adapter is connected correctly and that the instruments to be sprayed are used properly, see the MELAjet user manual. Wear protective gloves and goggles.

Opening the housing

- Never open the device housing. Incorrect opening and repair can compromise electrical safety and pose a danger to the user. The device may only be opened by an ►[authorised technician](#) who must be a ►[qualified electrician](#).

Notification requirement in the event of serious incidents in the European Economic Area

- Please note that all serious incidents that occur in relation to a ►[medical device](#) (e.g. death or a serious deterioration in a patient's state of health), which were presumably caused by the device must be reported to the manufacturer (MELAG) and the competent authority of the member state in which the user and/or the patient resides.

3 Performance specifications

Intended use

The MELAtherm 20 is a washer-disinfector in accordance with ▶EN ISO 15883-1 and -2 and is used for automated cleaning and thermal disinfection of reprocessible thermostable medical devices.

The device is primarily intended for use in a medical context such as a clinic or medical and dental practices.

Typical user groups are doctors, trained personnel and service technicians.

The washer-disinfector is not intended for use on patients or in the patient care area.

Performance features

Universal use

The device both cleans and disinfects. The disinfection phase is conceived so as to reach an ▶A0 value of min 3000. This kills vegetative bacteria and fungi or spores and inactivates viruses (incl. HBV, HCV). This means that ▶effective range AB is reached in accordance with the specifications of the ▶RKI (Robert Koch Institute).

Active drying

The device is equipped with active drying. An integrated drying fan dries the instruments from outside and in after cleaning and disinfection. The HEPA filter guarantees drying with contamination and particle-free air. This protects the instruments against corrosion. Manual subsequent drying is usually not necessary. The geometry of some hollow-body instruments mean that they require additional drying.

Automatic sieve recognition

The device recognises automatically, before a program starts, whether the fine sieve has been inserted in the base of the washing chamber. The fine sieve prevents instrument parts from entering the opening of the drain pump or the circulation pump during cleaning, which would impair the function of the pumps, rinse arms and the injector rail.

Internal water softening

The device is equipped with an internal water softening unit. The water hardness of the local drinking water is set in the device. The internal water softening unit then automatically adjusts itself to the most suitable performance. This ensures an optimal reprocessing result.

Monitoring the speed of the rinse arms

The speed of the rinse arms is subject to permanent monitoring during a program run. This ensures that the cleaning process runs smoothly and the rinse arms do not become blocked, e.g. by upright instruments in the washing chamber.

Rinse pressure monitoring

The rinse pressure is monitored by a pressure sensor during a program run. This ensures effective cleaning performance. The device cancels a running program if too much foam is generated.

Metering monitoring

The required quantities of ▶cleaning agent and ▶neutraliser are each metered by a metering pump. A measuring turbine monitors flow. The ▶rinse aid is metered by a timed metering pump.

Automatic conductivity measurement

If the device is supplied with ▶DI water in the final rinse, the DI water fed in is subject to automatic internal conductivity measurement.

Batch counter

After each completed program or at the end of a cancelled program, the batch number of the last program run and the total batch counter are shown on the display.

Program sequence

The following program steps are shown on the display during the program run. The program runs are defined by the so-called process-relevant parameters (▶VRP). The process-relevant parameters can be viewed in the menu.

Precleaning

Water-soluble soiling is rinsed roughly with cold water and removed from the device. This prevents protein fixing from too high a water temperature and the contamination load of the ▶rinse liquor in the following program steps is reduced considerably.

Cleaning

Water is fed into the washing chamber and heated. When the metering temperature is reached, mildly alkaline ▶cleaning agent is added. The holding time begins when the cleaning temperature is reached.

Neutralising

The cleaned instruments are freed from alkali residue during neutralisation. At the same time, this prevents the development of acid-soluble deposits such as limescale and extraneous corrosion. To this end, water is fed into the washing chamber, a citric acid-based ▶neutraliser is added and circulation occurs takes place for a short time.

Intermediate rinsing

Water is fed into the washing chamber and circulated cold. This rinses off neutraliser residues. This step is carried out twice in the **Ophthalm** program.

Disinfecting

The disinfection is the same as the final rinse. The cleaned and rinsed instruments are subject to thermal disinfection. Water, preferably ▶DI water is fed into the washing chamber and heated. In the **Universal**, **Universal+** and **Intensive** program, a ▶rinse aid is added on reaching the metering temperature. Once the disinfection temperature has been reached the holding time begins, which ensures a reproducible disinfectant effect.

Drying

Active drying is effected by drawing ambient air through a class H13 ▶HEPA filter and heating it. The instruments are dried inside and out with hot, filtered air.

Process agents

Comply with the following for safe handling:

- Handle all ▶process agents with care. Some cleaning agents, neutralisers and rinse aids contain irritant or even caustic substances.
- Follow the safety instructions in the process agents' documentation and wear the specified protective equipment. The MEtherm safety data sheets can be found on the MELAG website: <https://www.melag.com/sds>
- Note that any type of liquid in the device, or liquid that leaks from the device in case of damage, may contain aggressive process agents.
- Only MEtherm process agents are approved by MELAG. Other process agents have not been tested or checked by MELAG and, in the worst case, can lead to damage to the washer-disinfector and the instruments. In such a case, MELAG does not accept any liability.
- MEtherm process agents are optimally adapted for the ▶reprocessing with MELAtherm. The suitability has been proven in comprehensive cleaning effectiveness and material-compatibility tests.
- Please address all queries relating to the compatibility of process agents with the instruments to the instrument manufacturer.
- Every change of a process agent in a validated device necessitates revalidation. Comply with all national regulations.

Preset metering concentration

The metering concentrations adapted for MEtherm are set in the factory to the following values.

| Reprocessing program | ▶Cleaning agent | ▶Neutraliser | ▶Rinse aid |
|----------------------|-----------------|--------------|------------|
| Universal | 6 ml/l | 1.5 ml/l | 0.2 ml/l |
| Universal+ | 6 ml/l | 1.5 ml/l | 0.2 ml/l |
| Intensive | 10 ml/l | 1.5 ml/l | 0.2 ml/l |
| Ophthalmic | 6 ml/l | 1.5 ml/l | -- |

NOTICE

Warning: Incorrect setting

The metering concentration is changed only by trained and ▶authorised technicians taking into consideration the recommended use concentration.

4 Description of the device

Scope of delivery

Please check the scope of delivery before setting up and connecting the device.

- MELAtherm 20
- User manual
- Record of installation
- Manufacturer's inspection report and declaration of conformity
- Warranty certificate
- USB stick
- Funnel for salt container
- Regenerating salt for MELAtherm
- Key for container lid/salt container
- Rinse aid storage container (1 l)
- Ø 16-27/9 clamp for outlet hose
- Water inlet distributor 3/4" (Y-piece)
- Rubber seal 3/4" for external water connection
- Vapour barrier plate
- 3x Process agent tags
- Suction lance for cleaning agent (blue)
- Suction lance for neutraliser (red)
- Suction lance for rinse aid (black)
- 5x Hook and loop cable ties (black)
- 2x Anti-tilt device (incl. hex nut)
- Magnetic pocket for device logbook
- Allen key for door emergency opening

Views of the device

View from the front

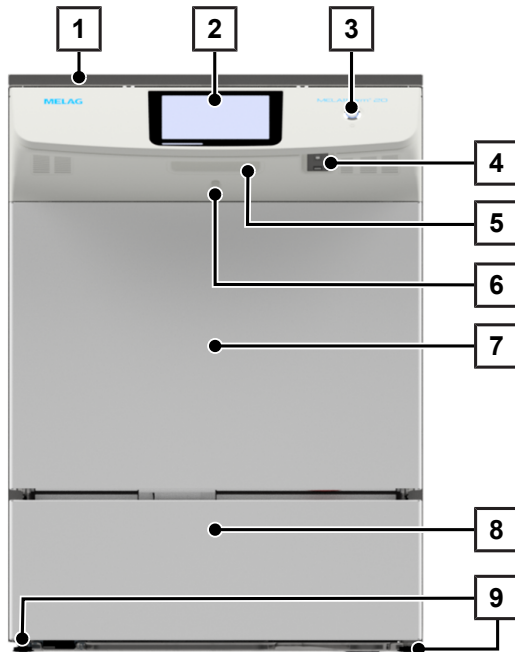

- 1 Stainless steel cover plate (optional)
- 2 Operating and display panel
- 3 Power button
- 4 USB port
- 5 Door handle
- 6 Manual door emergency opening
- 7 Hinged door, opens forwards
- 8 Plinth panel
- 9 Device feet

View of plinth (without panel)

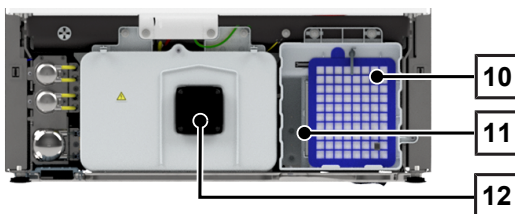

- 10 HEPA filter of the drying fan
- 11 Allen key for door emergency opening (5 mm)
- 12 E-Box air filter

View of washing chamber

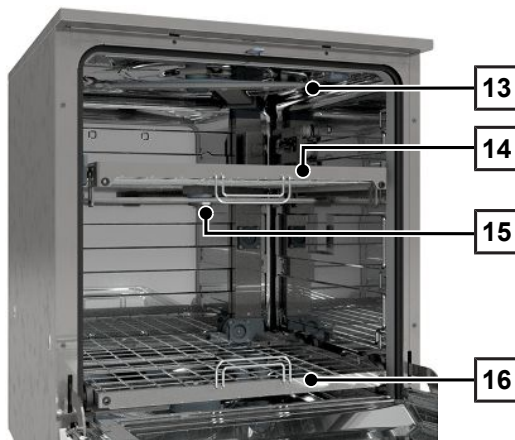

- 13 Upper rinse arm
- 14 Upper basket
- 15 Middle rinse arm
- 16 Lower basket

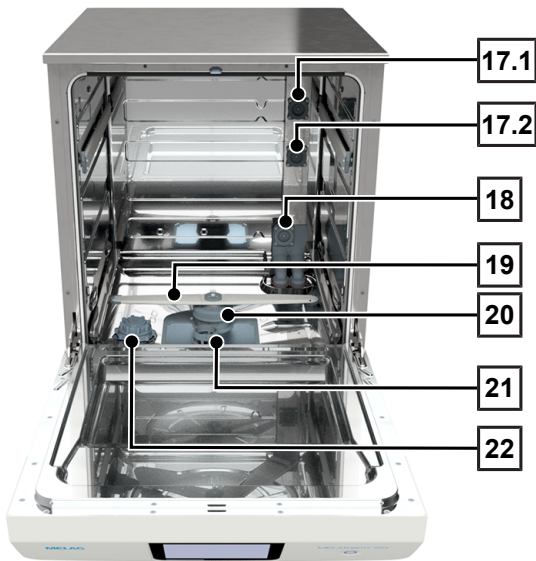

- 17.1 Connector for upper basket
- 17.2 Connector for upper basket or DIN sieve trolley
- 18 Connector for lower basket
- 19 Lower rinse arm
- 20 Cover, pump sump or central filter
- 21 Flat sieve and fine sieve
- 22 Salt container

View from the rear

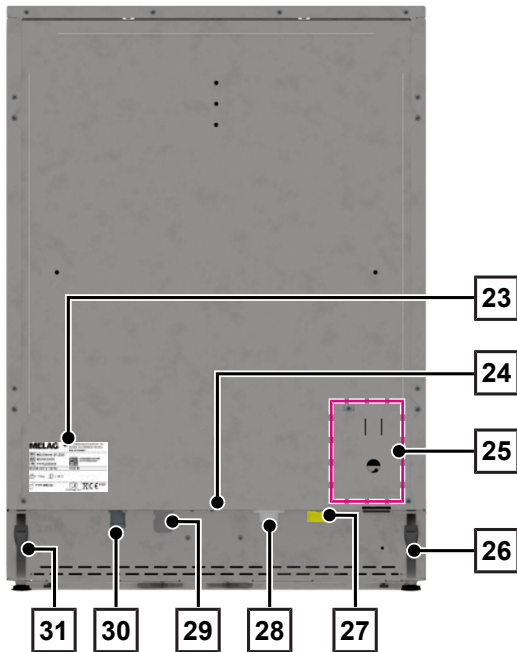

- 23 Type plate
- 24 USB/Ethernet connection
- 25 Metering system interface
- 26 Clamp for hose routing
- 27 DI water connection, see PLEASE NOTE
- 28 Cold water connection (CW)
- 29 Mains connection
- 30 Wastewater connection (WW)
- 31 Clamp for hose routing

PLEASE NOTE

If the device is operated without DI water, then cold water is also supplied via the DI water connection. The connections for DI water and cold water must always be connected to the water supply.

Symbols on the device

Type plate



Manufacturer of the product



Date of manufacture of the product



Label as medical device



Article number of the product



Serial number of the product



Observe user manual or electronic user manual



Do not dispose of product in household waste



CE marking



Identification number of the notified body responsible for conformity assessment according to Regulation (EU) 2017/745 on medical devices



Permissible temperature range of water supply



Permissible pressure of water supply



Electrical connection of the product: Alternating current (AC)

Other symbols



Protective earth connection

Warning symbols



This symbol indicates that the device is live. Contact with live parts result in serious injury and danger to life.



The marked area becomes hot during operation. Contact with it during or shortly after operation can pose the danger of burns.



This symbol indicates an interface for fluids. These fluids can contain irritant substances. Protect eyes, hands, clothing and surfaces from contact with these fluids.

Operating panel

The user interface consists of a 7-inch colour touch display.

The selected menu item is highlighted in colour.

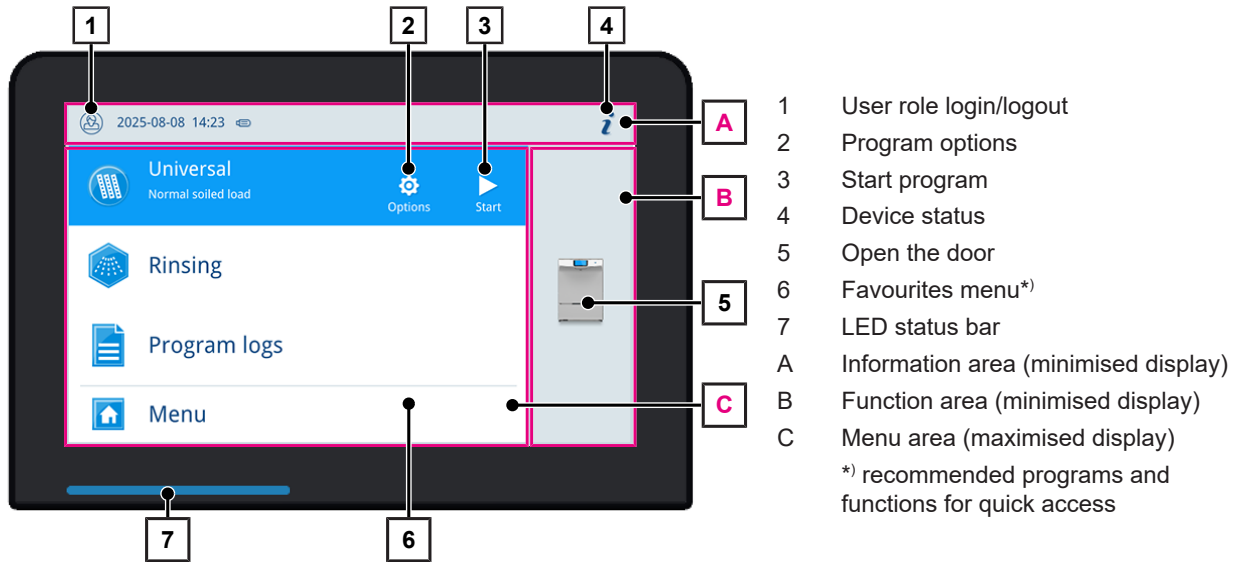

The display of the areas (A, B, C) is dynamic and can change depending on the operating state. This means that the display and position of the buttons on the device can differ from the figure shown.



Buttons and icons in the information area



User role

Individual permissions are assigned to each user role. To perform certain functions, the user must log in with a PIN if necessary.



| Button | Name | Description |
|---|--------------------|---|
|  | Practice employee | Operating the device General settings |
|  | Administrator | Operating the device General settings Login with admin PIN: administrative settings |
|  | Service technician | Operating the device General settings Login with service PIN: administrative settings Login with service PIN: service settings |

Output medium

Various output media are available for output of the logs. The output medium activated in the settings is displayed by the corresponding symbol.

| Icon | Name | Description |
|---|------------|--|
|  | MELAttrace | Pale display: The output medium is activated but not connected. |
|  | FTP | Full display: The output medium is activated and connected. |
|  | USB | No display: The output medium is not activated. |

Device status

| Button | Name | Description |
|---|---------------|---|
|  | Device status | Show or hide Device status menu The Device status menu lists device data such as serial number, conductivity, switching and sensor statuses. |
|  | Warning | Warning message present Show or hide warning message |
|  | Malfunction | Malfunction message present Show or hide malfunction message |

LED Status bar and acoustic signals

The LED below the display indicates operating states by colour and is lit continuously. An acoustic signal is linked to the LED colour and indicates an event.

The LED is switched off if the system is in the idle state or has been shut down and during a software update.

| LED colour | Operating state |
|------------|--|
| Blue | Device ready for operation, no program active Program active Door is open |
| Green | Drying active and can be terminated prematurely Program successful |
| Yellow | Warning |
| Red | Program not successful due to user cancellation Program not successful due to system termination Malfunction message |

Favourites menu

The Favourites menu provides fast access to frequently used programs and functions. The preferred reprocessing program, the **Rinsing** service program and the **Program logs** and **Menu** buttons are available to choose from.

The service program and the buttons are displayed continuously and cannot be changed. The **Universal** reprocessing program is displayed by default. The administrator can change this according to the practice's speciality, see [Favorites](#) [▶ page 157].

Views of the Favourites menu

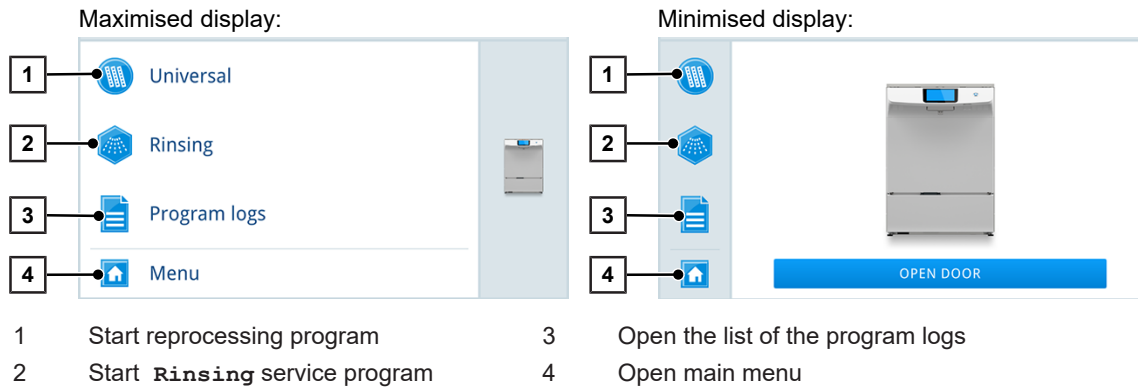

Menu structure

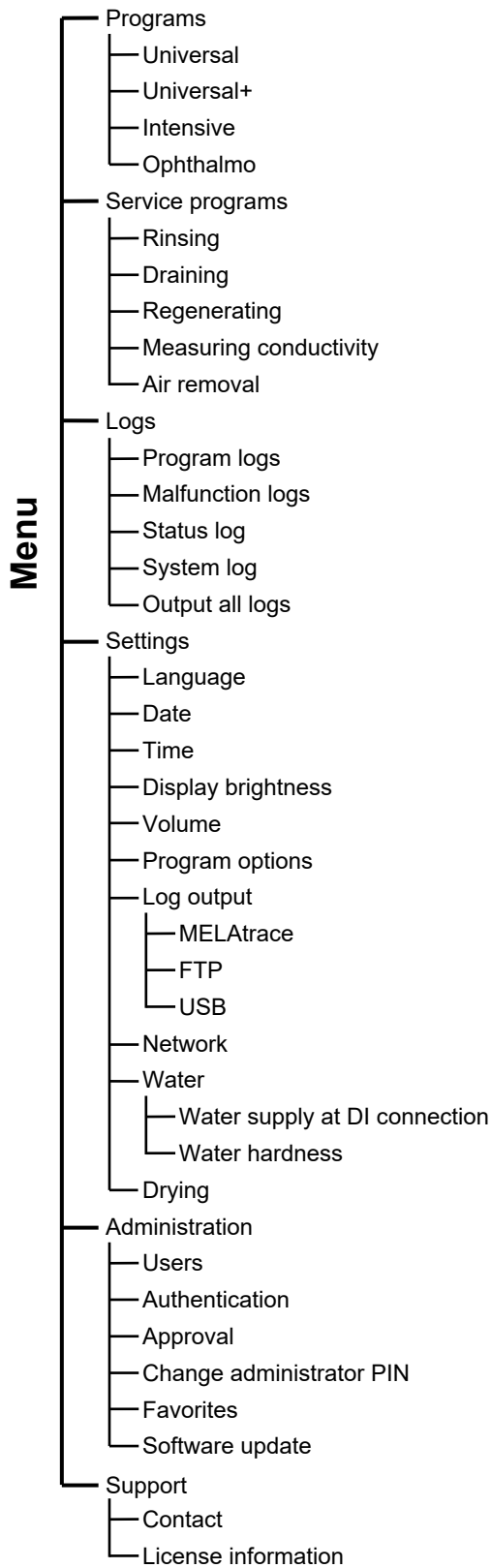

Water softening unit

The tap water is processed in the internal water softening unit to produce an optimal cleaning outcome.

- ▶ Use coarse-grain regeneration salt (NaCl) to regenerate the water softening unit.

Water hardness conversion table

| °dH | mmol/l | °f | °e | °dH | mmol/l | °f | °e | °dH | mmol/l | °f | °e |
|-----|--------|----|----|-----|--------|----|----|-----|--------|----|----|
| 1 | 0.2 | 2 | 2 | 15 | 2.7 | 27 | 19 | 28 | 5.0 | 50 | 36 |
| 2 | 0.4 | 4 | 3 | 16 | 2.9 | 29 | 20 | 29 | 5.2 | 52 | 37 |
| 3 | 0.5 | 5 | 4 | 17 | 3.1 | 31 | 22 | 30 | 5.4 | 54 | 38 |
| 4 | 0.7 | 7 | 5 | 18 | 3.2 | 32 | 23 | 31 | 5.6 | 56 | 39 |
| 5 | 0.9 | 9 | 7 | 19 | 3.4 | 34 | 24 | 32 | 5.8 | 58 | 41 |
| 6 | 1.1 | 11 | 8 | 20 | 3.6 | 36 | 25 | 33 | 5.9 | 59 | 42 |
| 7 | 1.3 | 13 | 9 | 21 | 3.8 | 38 | 27 | 34 | 6.1 | 61 | 43 |
| 8 | 1.4 | 14 | 10 | 22 | 4.0 | 40 | 28 | 35 | 6.3 | 63 | 44 |
| 9 | 1.6 | 16 | 12 | 23 | 4.1 | 41 | 29 | 36 | 6.5 | 65 | 46 |
| 10 | 1.8 | 18 | 13 | 24 | 4.3 | 43 | 31 | 37 | 6.7 | 67 | 47 |
| 11 | 2.0 | 20 | 14 | 25 | 4.5 | 45 | 32 | 38 | 6.8 | 68 | 48 |
| 12 | 2.2 | 22 | 15 | 26 | 4.7 | 47 | 33 | 39 | 7.0 | 70 | 49 |
| 13 | 2.3 | 23 | 17 | 27 | 4.9 | 49 | 34 | 40 | 7.2 | 72 | 51 |
| 14 | 2.5 | 25 | 18 | | | | | | | | |



5 Installation requirements

Installation location

▲ WARNING**Warning of material damage and injury**

Failure to comply with the setup conditions can lead to injuries and/or damage to the device.

- The device is not suitable for operation in explosive atmospheres.
- The device is intended for use outside the patient care area. The device should be located a minimum of 1.5 m radius away from the treatment area.

Steam egress can occur during operation. Do not set up the device in the immediate proximity of a smoke detector. Maintain clearance from materials which could suffer damage from steam.

Make sure that the ambient conditions meet the requirements, see [Technical data](#) [▶ page 178].

Electromagnetic environments

When assessing the electromagnetic compatibility (EMC) of this device, the emission limits for Class B devices and the immunity for operation in a basic electromagnetic environment are based on [IEC 61326-1](#). The device is thus suitable for operation in all facilities including those in residential areas and those that are directly connected to a public mains supply that also supplies buildings used for residential purposes. The floor should be made of wood or concrete or be tiled with ceramic tiling. If the floor is fitted with synthetic material, the relative humidity must be at least 30 %. Humidity reduces the development of electrostatic discharges.

Setup variants

You can set up the device in the following manner:

Free-standing using the stainless steel cover plate and the wall mount.

Next to existing base cabinets in the practice using the optionally supplied stainless steel cover plate. The space requirement is then at least 60 cm in width and 60 cm depth.

As a semi-integrated unit in a recess provided with existing continuous worktop.

Please note the following:

- The device is in a dry, dustproof position and free from vibrations and shocks.
- There are no interfering installations (e.g. hoses, cables, pipes, sockets, etc.) in the rear wall area.
- The device is level and horizontal. It is possible to level out floor unevenness of max. 1 cm by adjusting the device feet.
- If necessary, adjust the disinfection temperature to the altitude of site, see [Exceptions when setting up at altitudes](#) [▶ page 36].



Connection diagram

NOTICE

Warning of malfunction

An improper installation of the device can lead to malfunctions during operation.

- Always adhere to the specified installation heights of the hoses, especially the outlet hose.

Connections with DI water supply

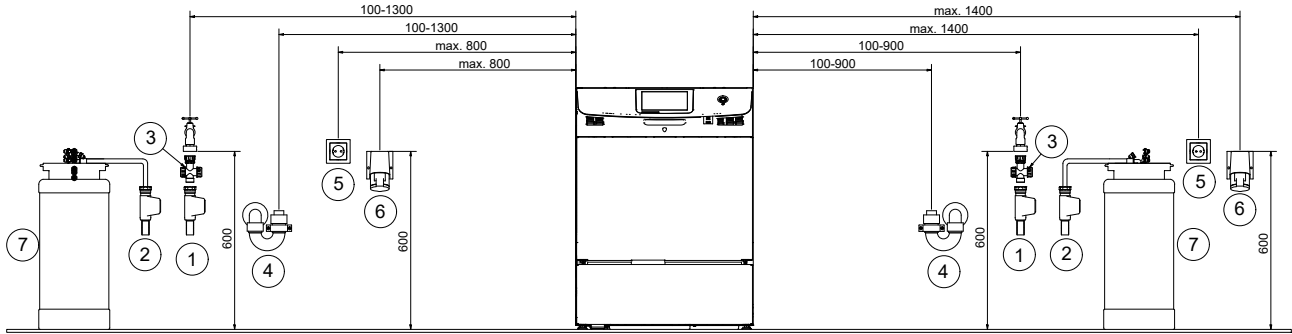

- | | |
|---------------------------------------|---|
| 1 Cold water inlet with aqua stop | 5 Type F (SCHUKO) socket |
| 2 DI water connection with aqua stop | 6 CEE socket |
| 3 Water inlet dirt trap (optional) | 7 Water treatment unit (e.g. MELAdem 53/53 C) |
| 4 Wastewater connection at the U-trap | → Process agent hoses: 2500 mm |

Connections without DI water supply

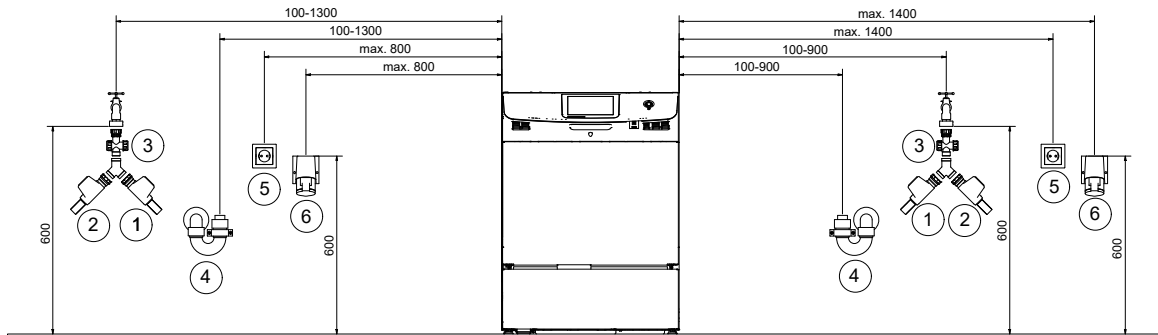

- | | |
|---------------------------------------|--|
| 1 Cold water inlet with aqua stop | 5 Type F (SCHUKO) socket |
| 2 Cold water inlet with aqua stop | 6 CEE socket |
| 3 Water inlet dirt trap (optional) | 7 Water inlet distributor 3/4" (Y-piece) |
| 4 Wastewater connection at the U-trap | → Process agent hoses: 2500 mm |



Space requirements

View from the front and from the left

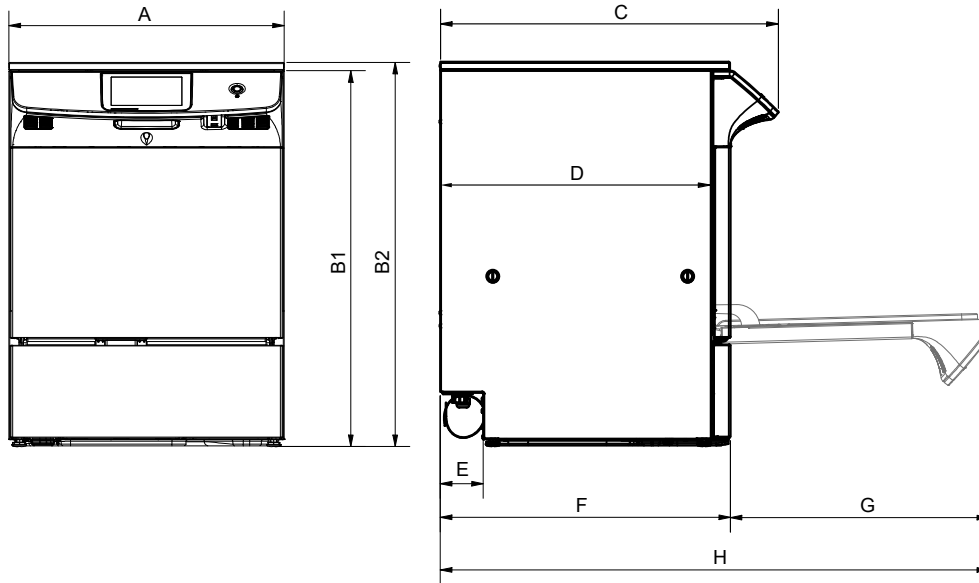

PLEASE NOTE

If the device is installed directly in the corner, e.g. of an L-shaped work surface, it is possible that existing drawers to the left or right of the device cannot be opened due to the protruding display unit.

| Dimensions | | | Description |
|--|----------------|----------|---|
| Width | A | 59.8 cm | Freestanding device: Freestanding using the optional stainless steel cover plate, for example, next to existing semi-integrated units. Semi-integrated unit: Space requirements in the work surface: min. 60 cm width, 60 cm depth and 82 cm height. PLEASE NOTE: If the device is to be flush with the adjacent cabinet fronts, the cabinets must be positioned so that the distance from the wall to the cabinet front is approx. 62.8 cm. |
| Height without stainless steel cover plate | B ₁ | 81.8 cm | |
| Height with stainless steel cover plate | B ₂ | 83.6 cm | |
| Depth with display | C | 73.0 cm | |
| Depth without door | D | 59 cm | |
| Hose routing depth | E | 9.4 cm | |
| Depth without display | F | 62.8 cm | |
| Door depth | G | 56.5 cm | |
| Depth with door open | H | 119.3 cm | |
| Min. distance from opposite work surface | -- | 1 m | |

Additional space requirements

Process agents

Process agent container:

Additional space for two 5 l containers and 1 l storage container is needed for the process agent containers.



MediaGuard Box (optional):

An additional space of 40 x 30 x 27 cm is needed for the MediaGuard Box.





Water treatment unit

Space is required above the MELAdem 53 / MELAdem 53 C for free access to the hose connections.

| Dimensions | MELAdem 53 | MELAdem 53 C |
|---|---|---|
| Diameter | 24 cm (26 cm incl. water inlet hose) | 24 cm (26 cm incl. water inlet hose) |
| Height of the unit incl. connecting parts | 57 cm (approx. 62 cm incl. connection kit) | 45 cm (approx. 49.5 cm incl. connection kit) |

On-site requirements

Mains connection

Make sure that the electrical connection meets the requirements on site, see [Technical data](#) [▶ page 178].

Electrical equipment must comply with DIN VDE 0100. A main switch (all-pole) must be installed on site. This must be marked as a disconnecter for the device and be easily accessible for the operator.

The electrical connection has cable cross-sections of 2.5 mm².

Water connection

Comply with the following for safe handling:

- Never shorten or damage the inlet and outlet hose for cold water/▶DI water.
- Never remove the dirt screen in the Aqua-Stop valve of the cold water inlet hose.
- Stains on the instruments or the device can develop from poor water quality. MELAG recommends a final rinse with DI water to avoid stains from forming on the instruments or in the washing chamber.

Make sure that the water connection meets the requirements on site, see [Technical data](#) [▶ page 178].

| Property | Cold water (CW) | Deionised (DI) water | Wastewater |
|----------------------------|---|---|---|
| Hose length ^{*)} | 1.9 m If necessary, it is possible to install a 3 m extension hose.**) | 2 m | 2 m Alternatively, it is possible to install a 4 m outlet hose.**) |
| Connection in the practice | To the shut-off valve (corner valve) for cold water | To a water treatment unit, e.g. MELAdem 53/ MELAdem 53 C | To a separate wall outlet (DN21) or an existing sink outlet Alternatively, a low-noise double chamber U-trap can be installed.**) NOTICE! The wastewater temperature can be up to 93 °C for short periods of time. |
| Additional requirements | No additional backflow preventer (check valve) required (internally secured against backflow into the potable water network according to ▶EN 1717) PLEASE NOTE: Observe the country-specific regulations on drinking water protection, e.g. SVGW, KIWA, WRAS. | The MELAdem 53/53 C is safeguarded by a combination of check valve and anti-vacuum valve according to EN 1717 | The outlet hose has a 90 ° bend at the rear of the unit. If the laying direction is disregarded, the bend may kink and impair draining of the device. |



| Property | Cold water (CW) | Deionised (DI) water | Wastewater |
|--|--|---|------------|
| Water quality | Drinking water according to the German Drinking water Ordinance (TrinkwV, Trinkwasserverordnung) or local regulations MELAG recommends the installation of a prefilter in the domestic water installation with a mesh size $\leq 100 \mu\text{m}$. | If using a central de-ionisation system, take into account the conductivity warning value: from $15 \mu\text{S/cm}$ | -- |
| <p>*) Note the information in the connection digram, see Connection diagram [▶ page 21].</p> <p>**) See Other equipment [▶ page 183]</p> | | | |

System and network safety

The device is fitted with multiple external interfaces. Comply with the following information pertaining to the use of these interfaces to ensure safe operation of the device, especially to ensure incorporation in the local network (LAN).

Interfaces and connections

Comply with the following for safe handling:

- Only connect the hardware to the device which is listed in the following table.
- Only use the software which has been intended for the purpose and approved by the manufacturer.
- When performing a device software update, use only the update data authorised by MELAG for the corresponding device type.

| Interface | Type | Hardware | Software/purpose |
|-----------|---------------------|--|--|
| USB | Type-B | USB type-A socket (via USB type-B to type-A cable) | MELAview Service Saving log data, querying device data using diagnostics mode |
| USB | Type-A | MELAG USB stick with FAT32 file system | Saving log data |
| | | MELAG USB stick with FAT32 file system and software update container | Device software update |
| Ethernet | Ethernet IEEE 802.3 | Switch port (Practical network) | MELAtrace saving log data, querying device data |
| | | | FTP server save log data |

Operating the device with memory media

To prevent data loss, only use memory media to save the log data with the following characteristics:

- functional (without malware, etc.)
- writeable
- formatted with a correct file system (FAT32)

Perform regular data backup. Restrict access to the device and systems with access authorisation to the necessary circle of persons.

Only use MELAG USB sticks.



Operating the device in the local network (LAN)

An Ethernet/IP-based network connection (LAN) is required to operate the device in a local network. In its delivery state, the device is configured to obtain the IP address automatically from a DHCP server operated in a LAN.

Comply with the following for safe handling:

- To avoid security vulnerabilities, do not connect the device to a public network (e.g. the internet).
- Check the IP address carefully during the conversion for a manual configuration before connecting the device to the LAN. An incorrectly-entered IP address can cause IP conflicts in the network and thus disturb another device in your network.

In the LAN with a firewall, only permit connections to and from the device which correspond to the intended use of the device. All ports not used are blocked on the device side.

The device is able to make the following connections as standard:

| Log | Source port | Destination port | Direction | Purpose |
|-----|---------------|------------------|------------------------|--|
| TCP | 63000 - 64000 | 21 | Outgoing | FTP control |
| TCP | any | 63000 - 64000 | Listening/ Incoming | FTP (passive) data transfer (device set to FTP logging) |
| UDP | 68 | 67 | Outgoing | Communication to DHCP server - requests to the DHCP server |
| UDP | 67 | 68 | Listening/ Incoming | Answers from DHCP server(s) |
| TCP | any | 3333 | Listening/ Incoming | Data transfer log data (device set to TCP logging) |
| UDP | 62000 | 3000 | Outgoing | Broadcast search printer |
| UDP | 3000 | 62000 | Listening/ Incoming | Search answers printer |
| TCP | ≥ 1025 | 9100 | Outgoing | Data transfer to the printer |

Network bandwidth/Quality of Service (QoS)

The device does not place any requirements on the LAN bandwidth for data transfer, that exceed the standard time-out times of the respective logs.

| Process | Volume max. | Volume normal |
|-----------------|-------------|---------------|
| Program log | 1 MB | 200 kB |
| Malfunction log | 64 kB | 10 kB |
| Status log | 64 kB | 20 kB |
| System log | 40 MB | -- |



6 Setup and installation

⚠ WARNING

Warning of material damage and injury

Improper installation can cause a short-circuit, fire, water damage or an electric shock. Serious injuries and/or damage to the device can result.

- The device should only be setup, installed and commissioned by MELAG authorised persons.

Comply with the following for safe handling:

- The disconnection device must be freely accessible after installation so that the device can be taken from the electricity supply at any time.
- The disconnection from the mains is made via the main switch on site.
- The device is not suitable for operation in explosive atmospheres.
- The device is intended for use outside the patient care area. The device should be located a minimum of 1.5 m radius away from the treatment area.
- Comply with all the specifications of this chapter for initial commissioning.

Record of installation

The record of installation must be completed by an [authorised technician](#), as evidence of proper setup, installation and initial commissioning and for warranty claims, and a copy sent to MELAG.

Removing from the packaging

⚠ CAUTION

Warning of injury

Lifting and carrying the device incorrectly can cause spinal damage, crushing injuries and bruising.

- Carry the device with at least two people.
- Comply with the safety regulations that apply to you.
- Use the carrying handles provided to carry the device.

The packed device and other packaging units are delivered on a disposable pallet (W x D x H: 1200 x 800 x max. 1600 mm).

The following must be fulfilled or present:

- ✓ Slotted screwdriver (min. 5.5)
 - ✓ 4x Carrying handle
1. Remove the packaging and leave the device on the shipping pallet.
 2. Check the device for any damage during transport.



3. Remove two plastic screws from each of the side walls. Tightly screw in the four carrying handles (pos. a) in these places.
4. **PLEASE NOTE:** The device has an empty weight of 74 kg-78 kg. Lift the device off the shipping pallet and carry it to the installation site.
5. Remove the four carrying handles (pos. a) from the side walls.
6. Tightly screw in the four plastic screws.

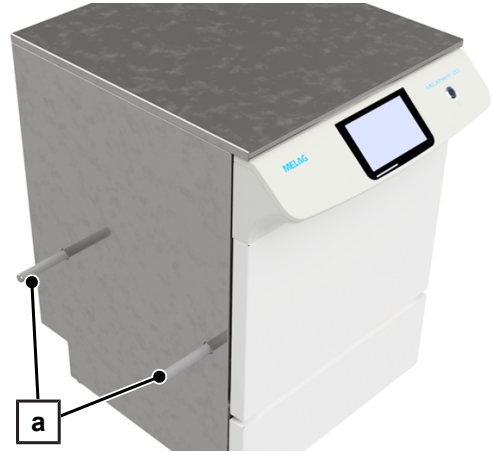

Connecting the inlet hoses and outlet hose

Comply with the following for safe handling:

- Installing the water stop (water leak detector) minimises the risk of water damage, see [Other equipment](#) [▶ page 183].
- Refer to the connection diagram, see [Connection diagram](#) [▶ page 21].

PLEASE NOTE

If the device is operated without DI water, then cold water is also supplied via the DI water connection. The connections for DI water and cold water must always be connected to the water supply.

Connections with DI water supply

The following must be fulfilled or present:

- ✓ Rubber seal 3/4" for external water connection

 1. Connect the outlet hose to the building's U-trap.
 2. Connect the CW/DI inlet hose to a water treatment unit or to a central demineralisation system.
 3. Connect the CW inlet hose including the rubber seal to the building's cold water inlet.

Legend:

WW = wastewater

CW = cold water

CW/DI = cold water or de-ionised water

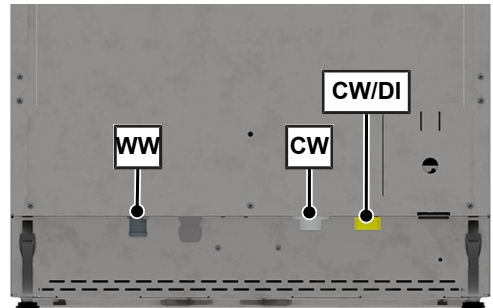

Connections without DI water supply

The following must be fulfilled or present:

- ✓ Water inlet distributor 3/4" (Y-piece)
- ✓ Rubber seal 3/4" for external water connection

 1. Connect the outlet hose to the building's U-trap.
 2. Connect the water inlet distributor to the building's cold water inlet.
 3. Connect the inlet hoses (CW and CW/DI), including the rubber gasket, to the water inlet distributor.

Legend:

WW = wastewater

CW = cold water

CW/DI = cold water or de-ionised water

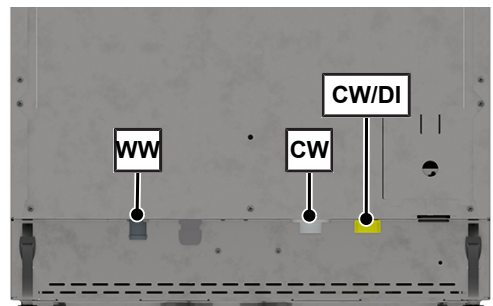



Installing the metering system

A colour is assigned to each process agent: ▶ **cleaning agent** = blue, ▶ **neutraliser** = red and ▶ **rinse aid** = black. When installing the metering system, the process agent hoses and cables for level monitoring are connected consistent with the coloured markings.

The process agent hoses and the cables for level monitoring are 2.5 m long.

PLEASE NOTE

A rinse aid is not used in ophthalmology. The rinse aid storage container together with the black suction lance, process agent hose and cable for the level monitoring is not needed. They are not installed.

Process agent container

CAUTION

Warning of chemical burns from irritant substances

Improper handling of the process agents can lead to chemical burns and health damage.

- Comply with the instructions provided by the manufacturer of the process agents.
- Protect your eyes, hands, clothing and all surfaces from contact with the process agents.

The following must be fulfilled or present:

- ✓ Process agent container for cleaning agent and neutraliser, and storage container for rinse aid if necessary
 - ✓ Suction lance including process agent hose and cables for the level monitoring for cleaning agent, neutraliser and rinse aid if applicable
 - ✓ Hook and loop cable ties (black)
1. Close the 5 l container for cleaning agent and neutraliser with the correct colour lids including suction lance.
 2. Pour the rinse aid into the 1 l storage container and close the storage container with the black lid including suction lance.

PLEASE NOTE: Fill the 1 l storage container up to the $\frac{3}{4}$ level only, so that the rinse aid does not overflow when the suction lance is inserted.

PLEASE NOTE

Do not place the process agents above the metering system interface. Gravity will cause the containers and the storage container to empty on their own.

- Do not place the process agents on the device or on a work surface.
 - Ensure that the containers and the storage container in an adjacent base cabinet are positioned on the lower level in an adjacent base cabinet.
3. Place the 5 l container and the 1 l storage container in the immediate vicinity of the device, e.g. in an adjacent base cabinet. MELAG recommends using the MediaGuard Box.
 4. Lay the process agent hoses and cables up to the metering system interface without kinks. Use the hook and loop cable ties supplied for tidy laying.

Setting up the MediaGuard Box

If a MediaGuard Box is to be used, set it up during device installation. The MediaGuard Box is not included with the device, see [Other equipment](#) [▶ page 183].

- ▶ Set up the MediaGuard Box, see separate instructions “Setting up the MediaGuard Box” (doc. AS_021-25).



Metering system interface

The interface of the metering system is located at the rear of the device.

The following must be fulfilled or present:

- ✓ Torx key (TX20)
- ✓ Combination pliers

1. Unscrew the screw (pos. a) of the cover plate (pos. b).
2. Remove the cover plate (pos. b).

3. Undo the nut of each clamp (pos. e).
4. Thread the process agent hoses and cables through the grommet (pos. f) from below. Pay attention to the layout (blue - red - black).
5. Use a clamp (pos. e) to fix the three shields on the device and tighten the nuts.
6. Connect the process agent hoses to the inlet sockets (pos. d) with the corresponding coloured marking.
7. Fix each hose at the socket with a clamp.
8. Connect the cables to the interface (pos. c) with the corresponding coloured marking.

9. Use the cable tie (pos. g) to fix the process agent hoses and cables below the interface.
PLEASE NOTE: The tie (pos. g) is used for strain relief and can be reopened if necessary.
10. Fit the cover plate (pos. b).

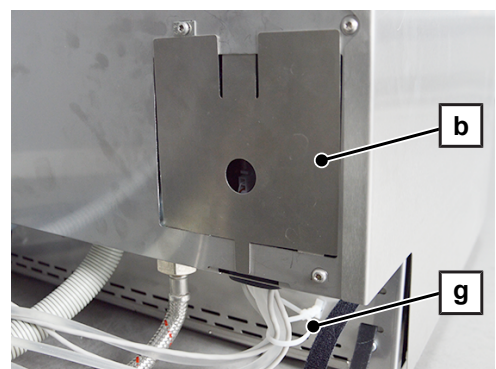
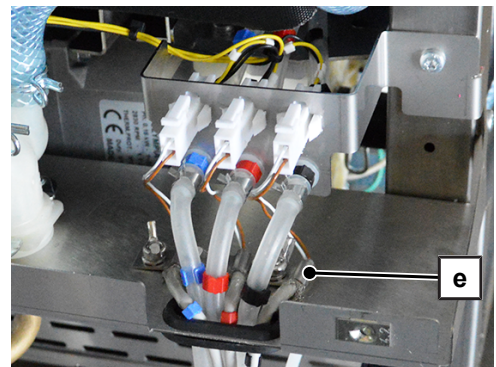
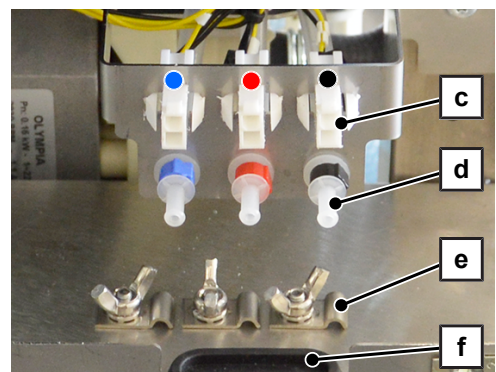
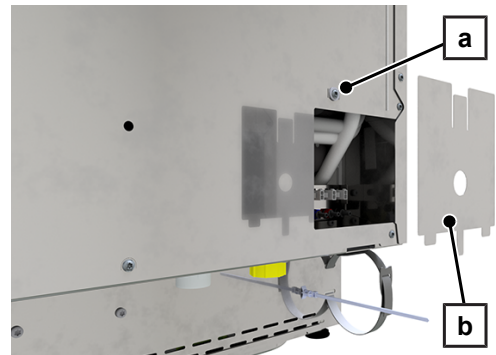



Fitting the anti-tilt device

The anti-tilt device must be fitted to set up a semi-integrated unit, i.e. in a recess provided with existing continuous worktop. The anti-tilt device is supplied with the device.

The following must be fulfilled or present:

- ✓ Open-end spanner (AF13)
1. Place the device in front of the recess provided under the worktop.
 2. Screw in the anti-tilt device (pos. a) on both sides, far enough so that they do not hinder final positioning of the device under the worktop yet still ensure stability.

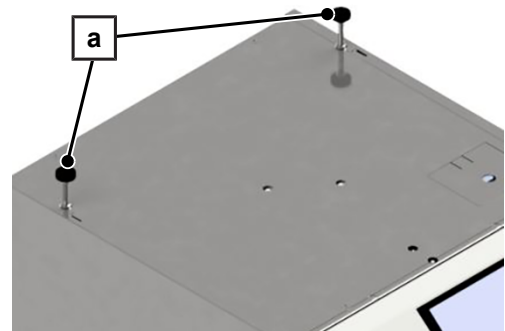

3. Tighten the lock nuts (pos. b) on both sides.

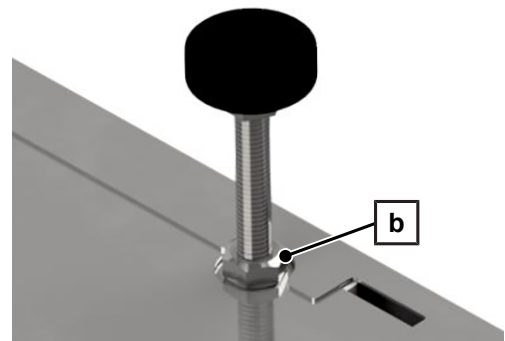

Positioning and aligning the device

NOTICE

Warning of damage to the hoses

Ensure that the hoses do not suffer kinking or crushing.

The following must be fulfilled or present:

- ✓ Spirit level
- ✓ Open-end spanner (AF13, AF24)
- ✓ For semi-integrated units: Vapour barrier plate incl. 8 screws
- ✓ The hoses for water inlet and outlet and for the metering system are connected.

1. If possible, lightly wet the floor. This makes it easier to push the device.
Tip: Use a synthetic oil (e.g. Rivolta T.R.S. Plus) to wet the floor.
2. Push the device gradually into position, at the same time adjusting the laying of the hoses accordingly.
PLEASE NOTE: Do not yet push the semi-integrated unit completely under the work surface.
3. Position a spirit level on the device.
4. Undo the locknuts of the front device feet.
5. Use an open-end spanner (AF24) to turn the front device feet in or out.
6. Use an open-end spanner (AF13) to tighten the locknuts of the device feet.

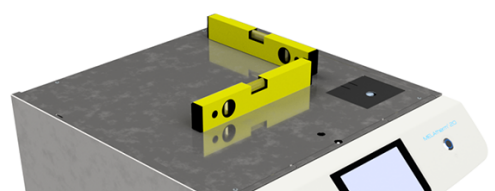



Semi-integrated unit:

7. Install the vapour barrier plate to the underside of the work surface above the door opening using the 8 screws.
8. Push the device completely under the work surface.

PLEASE NOTE

If, after the alignment, the device is in the final position and the door cannot be opened or closed properly, this can be due to unevenness of the floor. In this case, renewed alignment of the device with the help of the device feet makes sense.

Starting up the device and opening the door

1. Check the building's power connection.
2. Plug the power plug of the device into the mains socket.
3. Press the Power button.
4. Press **OPEN DOOR**.



Fitting the stainless steel cover plate

To set up a freestanding device, the stainless steel cover plate must be fitted and the device secured with the help of the wall mount. The stainless steel cover plate including wall mount is not included with the device, see [Other equipment](#) [▶ page 183].

- ▶ Fit the stainless steel cover plate and wall mount, see separate instructions “Fitting the stainless steel cover plate and wall mount” (doc. AS_015-25).

Inserting the central filter

If use of a central filter is planned, insert the filter in the frame of the device setup. The central filter is not included with the device.

1. Press the quick-release fastener (pos. a) of the lower rinse arm (pos. b) and remove the rinse arm.

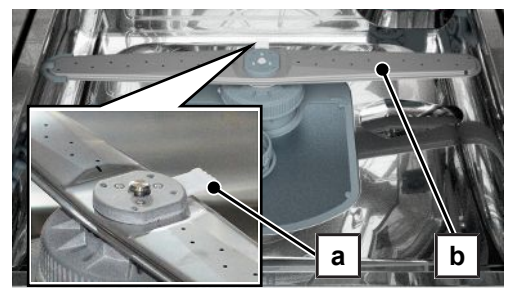



2. Turn the lid (pos. c) of the pump sump anti-clockwise to unscrew it.

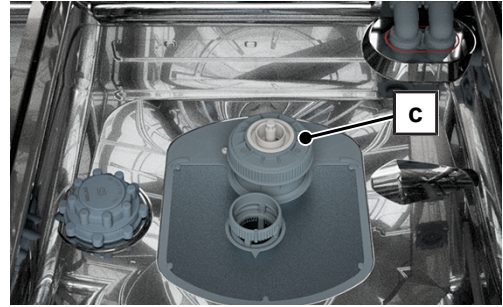

3. Insert the central filter, including lid (pos. d), into the pump sump (pos. e). Turn the central filter, including lid (pos. d), clockwise.

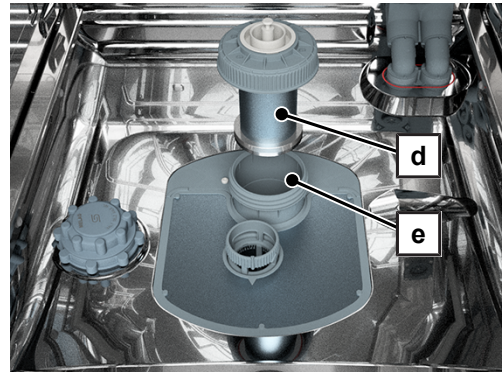

4. Press the quick-release fastener and re-insert the lower rinse arm.

Checking connection points

1. Check the O-ring of the salt container for unevenness, cracks and other noticeable flaws.
2. Check the salt container for tight fit. If necessary, use the Key for container lid/salt container to retighten the union nut.
3. Check the fit of the flat sieve. The flat sieve must be inserted flush in the bottom of the washing chamber.
4. Check the fixing and freedom of movement of the rinse arms.

Adjusting the levels of the basis baskets

The upper basket can be adjusted vertically. Three basket levels are available. Adjustment of the level depends on the height of the load.

The level is adjusted using three rollers (pos. a) on each side of the upper basket and the connection fittings (pos. b).

If the level of the upper basket is adjusted, the level of the lower basket changes.

On delivery, the highest level (level 1) is set by default.

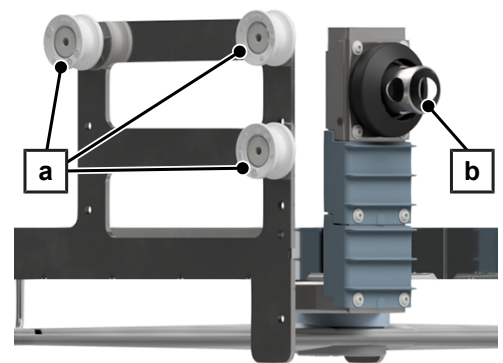

| Basket level | Upper basket level | Lower basket level |
|--------------|--------------------|--------------------|
| Level 1 | 160 mm | 280 mm |
| Level 2 | 200 mm | 240 mm |
| Level 3 | 240 mm | 200 mm |



Position of the rollers and the connection fitting

Level 1

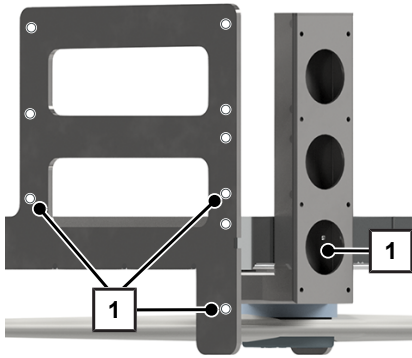

Level 2

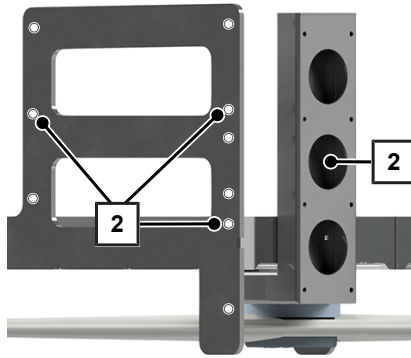

Level 3

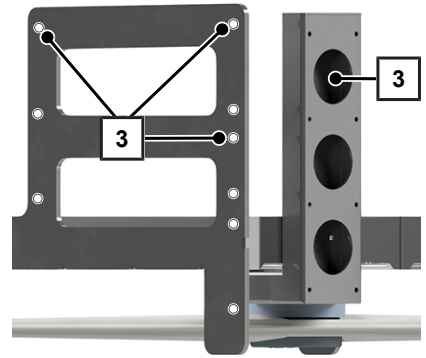

Adjusting the basket level

The following example shows the adjustment for the lower basket level.

The following must be fulfilled or present:

- ✓ Allen key (4 mm)
- ✓ Torx key (TX10)
- 1. Remove the upper basket from the washing chamber and place it on a clean, non-slip surface.
- 2. Undo the screws of the rollers (pos. a) and remove all rollers on both sides of the upper basket.
PLEASE NOTE: There is one washer on the inside of each roller.
- 3. Screw the rollers, each with one washer, into the holes of the required basket level and tighten the screws.
- 4. Fit the connection fitting (pos. b) on the basket level matching the rollers.
- 5. Fit the two panels (pos. c) on the levels that are not needed.

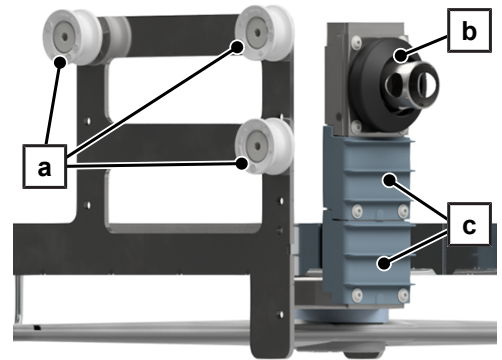

Commissioning

Service menu

The **Service** menu can be accessed by entering the service PIN. As a logged in service technician, among other things you can make basic settings, adjust factory parameters and reset the maintenance counter.



After installing the device, carry out the work described below as set out in the record of installation.

The following must be fulfilled or present:

- Precision scales (accuracy d = 0.1 g or better)
- Measuring cylinder with a scale up to 250 ml (± 2 ml)



Logging in/out as a service technician

Login

1. Press  in the information area of the display.
2. Select the **Service technician** user role.

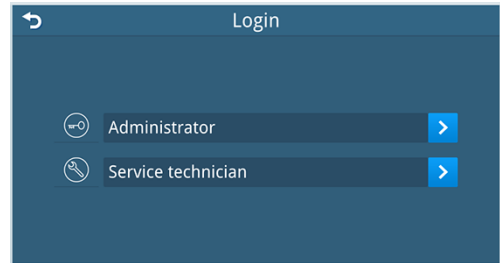

3. Enter the 4-digit service PIN.



➔ The User role button switches to .

Log out

1. Press  in the information area of the display.
2. Press **LOGOUT**.

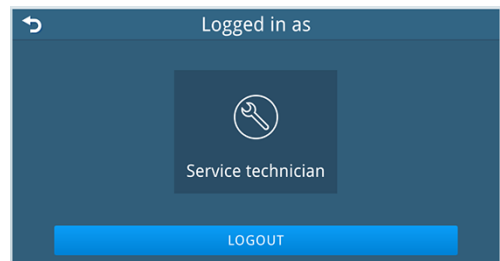

➔ The view switches to the Main menu.

➔ The User role button switches to .

Checking the software version

1. Press  in the information area of the display.
 - ➔ The **Device status** menu opens.
2. Use the scroll bar to navigate in the menu to **Software** and open the submenu.

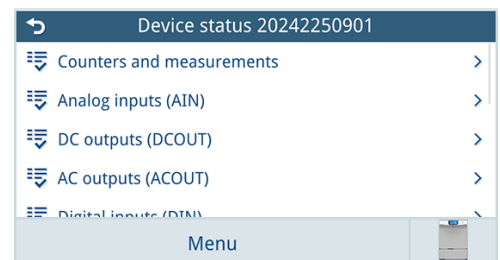



3. Check the software version.
4. Update the software if necessary, see [Software update](#) [▶ page 158].

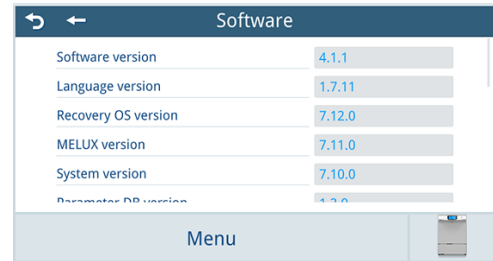

Determining and adjusting the water hardness

NOTICE

Warning of incorrect settings

An incorrectly set degree of hardness can result in a higher salt consumption or limescale deposits on the instruments. When using an internal practice water softening unit, the residual hardness of this water softening unit must also be set.

PLEASE NOTE

The installed water softening unit is optimised for a degree of hardness of 4-30 °dH. Degrees of hardness higher than 30 °dH, require an in-house water softening unit for the practice.

1. To obtain a precise value, let the water run for a while before the test.
2. Determine the local water hardness using a titration test (e.g. make: Caldur, Test set for water hardness), see [Other equipment](#) [▶ page 183].
3. Set the determined water hardness in the menu, see [Water hardness](#) [▶ page 149].

Filling the regenerating salt and regenerating the water softening unit

PLEASE NOTE

If a water hardness of 3 °dH or lower is determined and is set in the menu, there is no automatic regeneration of the device's internal water softening unit. The **Regenerating** service program is cancelled after a manual start and a message appears on the display.

In this case, MELAG recommends not using regenerating salt.

1. Before the initial commissioning, fill the salt container with water until it overflows so salt can dissolve in it.
2. Pour 1 kg regenerating salt to the salt container.
NOTICE! Do not operate the device if there is not enough salt in the container.
3. Wait for approx. 3 min before starting a program, so that the salt can dissolve.
4. Start the **Regenerating** service program.

PLEASE NOTE

If the commissioning is not continued immediately, run the **Rinsing** service program to remove any brine that may be present from the chamber.

Basic settings

1. Set the date and time, see [Date and time](#) [▶ page 140].
2. Make the settings necessary for recording and filing the logs, see [Log output](#) [▶ page 142].
3. Activate the authentication if necessary, see [Authentication](#) [▶ page 156].
4. Activate the approval option(s) for the batch approval, see [Approval](#) [▶ page 156].
5. Set the IP address of the practice network, see [Network](#) [▶ page 147].
6. Set the type of water supply, see [DI connection water supply](#) [▶ page 148].



Checking the metering concentration

The metering concentration for the initial commissioning is preset to the MEtherm ▶**process agents**, see **Process agents** [▶ page 9]. Adjust these settings if a process agent product used is changed or if the metering concentration increases according to the degree of soiling of the load.

The following must be fulfilled or present:

- ✓ The process agent containers are ready.
- ✓ The **Service > Parameter > Process relevant parameters** menu is open.

1. Select the program.



2. Check the metering concentration in the respective partial cycle and set the concentration again if necessary.

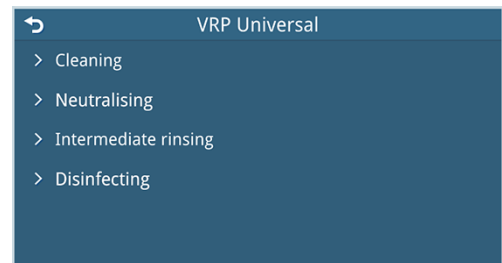

PLEASE NOTE

Observe the metering specifications of the process agent manufacturer. This information is provided on the container in unit of ml/l or % (10 ml/l = 1 %) and in separate data sheets of the respective manufacturer.

Exceptions when setting up at altitudes

At higher altitudes, the boiling temperature of the ▶**rinse liquor** is lower so that the disinfection temperature must be reduced and the disinfection period must be increased.

The altitude is set to 0-500 m above mean level by default. Adjust the setting if the device is to be operated at altitudes higher than 500 m.

PLEASE NOTE

A malfunction can occur if the parameter for setting the altitude is not adjusted to local circumstances.

The following must be fulfilled or present:

- ✓ The **Service > Parameter > Altitude** menu is open.

1. Set the altitude range valid for operation of the device.

2. Press **SAVE**.

- ➔ The temperature and the holding time for the **Disinfecting** partial cycle are adjusted in the system automatically.

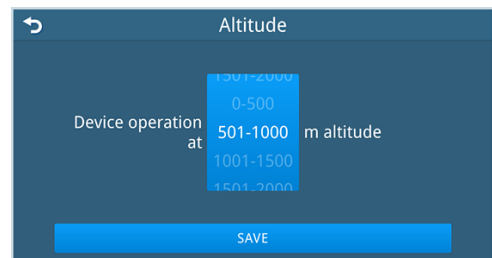



De-aerating the metering system

Before operating for the first time, run the **Air removal** service program.

1. Press **Start**.
2. Note the program information **Service program without reprocessing** and confirm with **START PROGRAM**.



Checking the metering accuracy

Determining the density of the process agents

| Density of MEtherm | | Different units for the density of the process agents |
|--------------------|-----------|---|
| MEtherm 51 | 1.06 g/ml | The different units can be used 1:1. Label: kg/l Safety data sheet: g/cm ³ MELAG document: g/ml |
| MEtherm 55 C | 1.17 g/ml | |
| MEtherm 61 | 0.99 g/ml | |

The density and filling level with the corresponding weight are indicated directly on the label of the MEtherm process agents. Alternatively, the density of the cleaning agent, neutraliser and rinse aid (not for ophthalmology) can be ascertained.

The following overview shows the determination of the density of a process agent. The procedure for all process agents is the same.

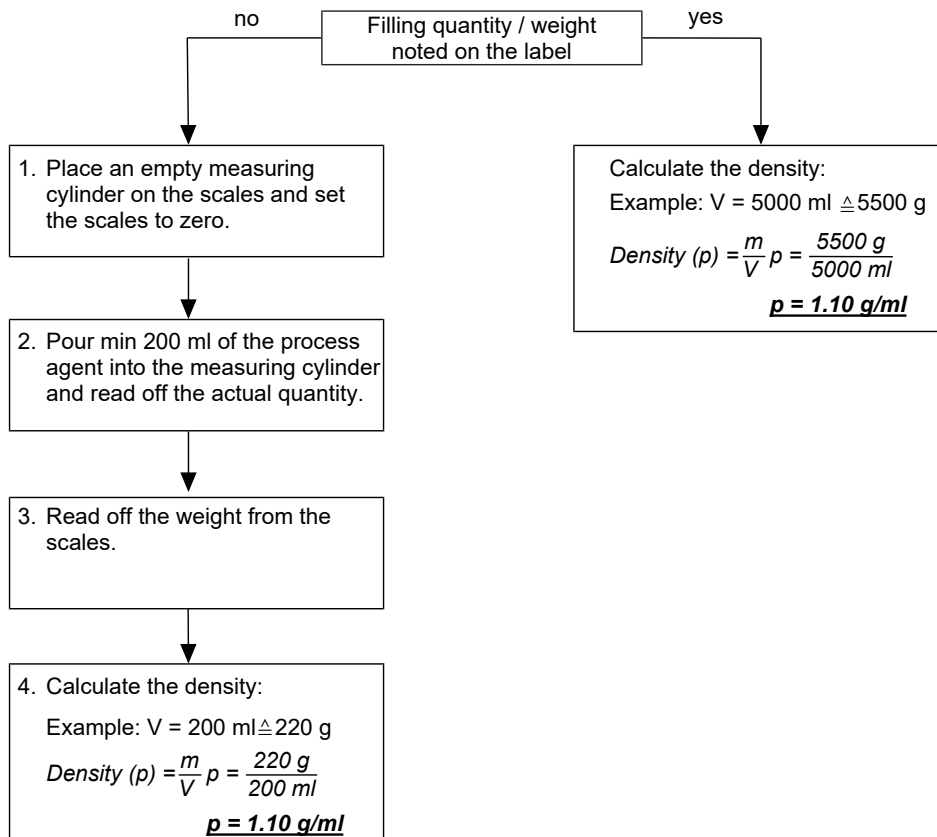



Determining the metering quantities of the process agents

After determining the density, determine the metering quantity in grams. During a reprocessing program, determine the metering quantities of cleaning agent, neutraliser and rinse aid consumed.

1. Place the ▶**cleaning agent** container on the scales and determine the total weight of the container or use the tare button to set the scales to zero.
2. Start the device with the basis baskets in the reprocessing program preferred by the practice.
PLEASE NOTE: In ophthalmology, the **Ophthalmo** program.
3. Check all connectors, chamber lead-throughs and connections for leaks while the program is running.
↳ The cleaning agent's metering pump starts audibly as soon as the **Cleaning** partial cycle is shown on the display and the metering temperature is reached. When the pump noise stops, the metering has ended.
4. Note the weight change in grams after metering the cleaning agent.
5. Remove the container with the cleaning agent from the scales.
6. Place the ▶**neutraliser** container on the scales and determine the total weight of the container or use the tare button to set the scales to zero.
↳ The neutraliser's metering pump starts audibly as soon as the **Neutralising** partial cycle appears on the display. When the pump noise stops, the metering has ended.
7. After the neutraliser has been metered, note the weight change in grams.
8. Remove the container with the neutraliser from the scales.

PLEASE NOTE Do not use any rinse aid for the **Ophthalmo** program.

9. Place the ▶**rinse aid** container on the scales and determine the total weight of the container or use the tare button to set the scales to zero.
↳ The rinse aid's metering pump starts audibly as soon as the **Disinfecting** is shown on the display and the metering temperature is reached. When the pump noise stops, the metering has ended.
10. Note the weight change in grams after metering the rinse aid.

Converting the determined metering quantities of the process agents

Based on the determined density and the metering quantities in grams it is possible to convert the metering quantity of the process agents to millilitres.

The following example shows the conversion of the metered quantity in millimetres. The procedure for all process agents is the same.

Example: In the **Universal+** program, e.g. 66 g was weighed for the process agent. The metering quantity is 66 g. In addition, a density of 1.1 g/ml was determined for the same process agent.

$$\text{Metering quantity [ml]} = \frac{\text{Metering quantity [g]}}{\text{Density [g/ml]}} \qquad \text{Metering quantity} = \frac{66 \text{ g}}{1.1 \text{ g/ml}} = \underline{\underline{60 \text{ ml}}}$$

Checking the metered quantity actual / target

1. Read off the metering nominal values from the program log and compare these to the previously determined metering quantities.
↳ A maximum deviation of ± 10 % is permissible.
2. If larger deviations occur, adjust the feed rate of the corresponding metering pump, see [Determining the feed rates/ calibration of the metering pumps](#) [▶ page 39].
3. Finally, check the actual metered quantity in the corresponding partial cycle, see [Determining the metering quantities of the process agents](#) [▶ page 38].



The following example shows how to determine the percentage deviation between the nominal and actual value of the metered quantity. The procedure for all process agents is the same.

$$x = \left(\frac{V(\text{actual})}{V(\text{target})} - 1 \right) \times 100$$

Example:

Calculated metering quantity: V (actual) = 28 ml
 Metering quantity acc. to log printout: V (target) = 27.8 ml

$$\left(\frac{28 \text{ ml}}{27.8 \text{ ml}} - 1 \right) \times 100 \implies \underline{x = 0.7 \%}$$

The check of the metering quantity reveals a deviation of 0.7 %.

4. Read off the nominal value of the process agent from the program log.
5. Compare the nominal value with the calculated actual value and determine the percentage deviation.

Determining the feed rates/calibration of the metering pumps

The feed rate of the process agent is the quantity metered per minute (ml/min). During the initial commissioning, the preset feed rates of the MEtherm process agents are displayed in the menu.

MELAG recommends using water to determine the feed rates. The weight (g) of water equals its actual volume (ml). The determined feed rates can be used 1:1 as **ml**.

The following must be fulfilled or present:

- ✓ Precision scales
 - ✓ Measuring cup or bucket (5 l)
 - ✓ The **Service > Parameter > Feed rate of metering pumps** menu is open.
1. Place the precision scales in the immediate vicinity of the device.
 2. Fill the measuring cup/bucket with lukewarm water and place the suction lances in it.
 3. Place the measuring cup/bucket on the precision scales.

Run the Air removal partial cycle

1. Select the process agent or the process agents for determining the feed rate of the metering line.
2. Press **START**.

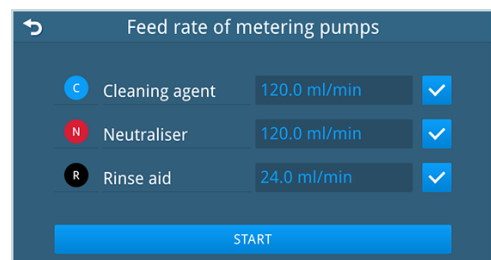

Air removal partial cycle not successful

If a metering line cannot be vented successfully, the partial cycle is cancelled and a warning message appears.

1. Confirm the message with **OK**.
2. Cancel the process.
3. Restart the partial cycle.



Air removal partial cycle successful/start determination of the feed rate

Determination of the feed rate begins as soon as the partial cycle has finished successfully. The dialogs of all selected process agents are displayed one after the other.

The sequence for the cleaning agent is described in the following. The sequence for the neutraliser and the rinse aid is the same.

1. Follow the instructions in the menu and then press **YES**.

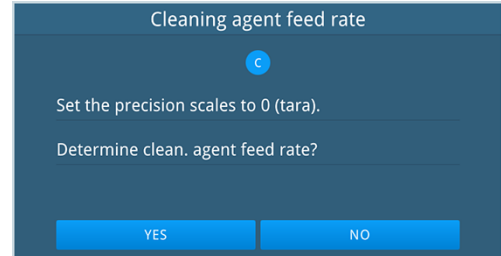

2. Set the measured value.
PLEASE NOTE: Only permissible values can be set. If a limit value is exceeded or not reached, repeat the process to determine the feed rate.



3. Press **SAVE**.
4. Determine the feed rate for neutraliser and rinse aid in the same way.
5. The saved values are displayed for checking. Press **OK**.

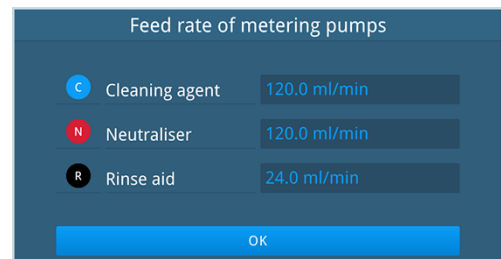

6. Screw the suction lances back into the corresponding process agent containers.

Run the Air removal service program

- ▶ De-aerate the metering system to remove the water, see [De-aerating the metering system](#) [▶ page 54].

Run the Rinsing service program

The following must be fulfilled or present:

- ✓ The **Air removal** service program was finished successfully.
- ✓ The **Menu > Service programs** is displayed.

1. Select **Rinsing** and press **Start**.
2. Note the program information **Service program without reprocessing** and confirm with **START PROGRAM**.

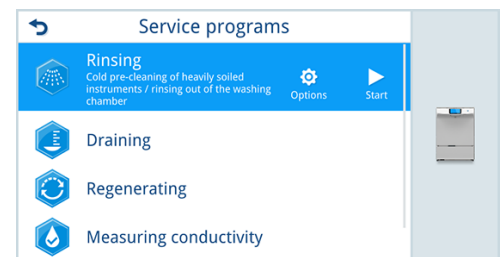



Process-relevant parameters

Comply with the following for safe handling:

- Improper changes to the parameters can lead to personal injury and/or property damage as well as damage to the device. MELAG does not accept any liability for such damage.

When the device is delivered, the process-relevant parameters (VRP) of the individual programs have already been set in the factory, see following tables.

If changes are made to the factory-set parameters during commissioning, then enter these in the record of installation.

- If necessary, make changes in the **Service** menu > **Parameter** > **Process relevant parameters**.



Example diagram of VRP Universal+

The diagrams of the process-relevant parameters (VRP) can be output via the respective program logs, see [Outputting program logs or malfunction logs](#) [page 135].

The layout of a diagram of the **Universal+** reprocessing program is shown in the following. The layout of the diagrams is the same for all programs.

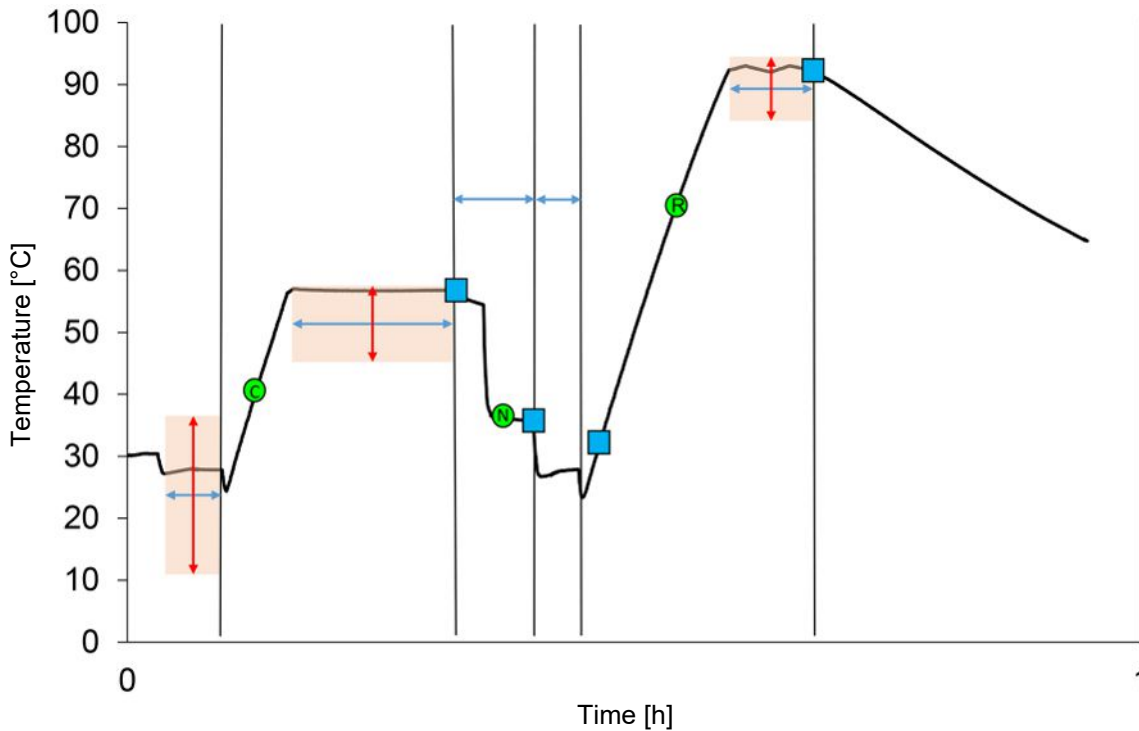

Key

- Washing chamber temperature [°C]
- Holding time [s]
- Temperature [°C]
- Validation stop
- Metering
C = cleaning agent
N = neutraliser
R = rinse aid



VRP factory settings

The following tables list the factory default settings In and the permissible minimum to maximum setting options — Default [min.-max.] (e.g. 1 [1-3]).

VRP Universal

| Partial cycle (PC) → | Pre-cleaning | Cleaning | Neutralising | Intermediate rinsing | Disinfecting | Drying |
|-------------------------------|--------------|-------------------|----------------|----------------------|--------------------|--------------------|
| VRP ↓ | | | | | | |
| Repeat partial cycle | -- | 1 | 1 | 1 [1-3] | 1 | 1 |
| Holding time [s] | -- | 360 [360-1200] | 60 [60-120] | 60 [60-120] | 300 [300-1090]* | 900**) 1800***) |
| Temperature [°C] | -- | 55 [45-60] | -- | -- | 90 [85-90]* | 75 |
| Metering temperature [°C] | -- | C: 40 [30-50] | -- | -- | R: 70 | -- |
| Metering concentration [ml/l] | -- | C: 6 [1-10] | N: 1.5 [0-5] | -- | R: 0.2 [0-1] | -- |
| Quantity of water [l] | -- | 11 | 9 [9-11] | 9 [9-11] | 9 [9-11] | -- |
| DI proportion [0=OFF, 1=ON] | -- | 0 [0-1] | 0 [0-1] | 0 [0-1] | 1 [0-1] | -- |

*) automatic depending on altitude | **) in **Power** mode of PC Drying | ***) in **Normal** mode of PC Drying

VRP Universal+

| Partial cycle (PC) → | Pre-cleaning | Cleaning | Neutralising | Intermediate rinsing | Disinfecting | Drying |
|-------------------------------|------------------|-------------------|----------------|----------------------|--------------------|--------------------|
| VRP ↓ | | | | | | |
| Repeat partial cycle | 1 [1-3] | 1 | 1 | 1 [1-3] | 1 | 1 |
| Holding time [s] | 120 [120-600] | 690 [690-1200] | 60 [60-120] | 60 [60-120] | 300 [300-1090]* | 900**) 1800***) |
| Temperature [°C] | 18 [0-37] | 55 [45-60] | -- | -- | 90 [85-90]* | 75 |
| Metering temperature [°C] | -- | C: 40 [30-50] | -- | -- | R: 70 | -- |
| Metering concentration [ml/l] | -- | C: 6 [1-10] | N: 1.5 [0-5] | -- | R: 0.2 [0-1] | -- |
| Quantity of water [l] | 11 | 11 | 9 [9-11] | 9 [9-11] | 9 [9-11] | -- |
| DI proportion [0=OFF, 1=ON] | 0 [0-1] | 0 [0-1] | 0 [0-1] | 0 [0-1] | 1 [0-1] | -- |

*) automatic depending on altitude | **) in **Power** mode of PC Drying | ***) in **Normal** mode of PC Drying

VRP Intensive

| Partial cycle (PC) → | Pre-cleaning | Cleaning | Neutralising | Intermediate rinsing | Disinfecting | Drying |
|-------------------------------|------------------|-------------------|----------------|----------------------|--------------------|--------------------|
| VRP ↓ | | | | | | |
| Repeat partial cycle | 1 [1-3] | 1 | 1 | 1 [1-3] | 1 | 1 |
| Holding time [s] | 120 [120-600] | 840 [840-1200] | 60 [60-120] | 60 [60-120] | 300 [300-1090]* | 900**) 1800***) |
| Temperature [°C] | 18 [0-37] | 55 [45-60] | -- | -- | 90 [85-90]* | 75 |
| Metering temperature [°C] | -- | C: 40 [30-50] | -- | -- | R: 70 | -- |
| Metering concentration [ml/l] | -- | C: 10 [1-10] | N: 1.5 [0-5] | -- | R: 0.2 [0-1] | -- |
| Quantity of water [l] | 11 | 11 | 11 [9-11] | 11 [9-11] | 11 [9-11] | -- |
| DI proportion [0=OFF, 1=ON] | 0 [0-1] | 0 [0-1] | 0 [0-1] | 0 [0-1] | 1 [0-1] | -- |

*) automatic depending on altitude | **) in **Power** mode of PC Drying | ***) in **Normal** mode of PC Drying



VRP Ophthalmic

| Partial cycle (PC) → | Pre-cleaning | Cleaning | Neutralising | Intermediate rinsing | Disinfecting | Drying |
|--------------------------------|------------------|-------------------|----------------|----------------------|--------------------|--------------------|
| VRP ↓ | | | | | | |
| Repeat partial cycle | 1 [1-3] | 1 | 1 | 2 [2-3] | 1 | 1 |
| Holding time [s] | 120 [120-600] | 570 [570-1200] | 60 [60-120] | 60 [60-120] | 300 [300-1090]* | 900**) 1800***) |
| Temperature [°C] | 18 [0-37] | 55 [45-60] | -- | -- | 90 [85-90]* | 75 |
| Metering temperature [°C] | -- | C: 40 [30-50] | -- | -- | -- | -- |
| Metering concentration [ml/l] | -- | C: 6 [1-10] | N: 1.5 [0-5] | -- | -- | -- |
| Quantity of water [l] | 11 | 11 | 11 [9-11] | 11 [9-11] | 11 [9-11] | -- |
| DI proportion [0=OFF, 1=ON] | 0 [0-1] | 0 [0-1] | 0 [0-1] | 1 [0-1] | 1 [0-1] | -- |

*) automatic depending on altitude | **) in **Power** mode of PC Drying | ***) in **Normal** mode of PC Drying

Water supply without DI water

PLEASE NOTE

In the menu **Process relevant parameters**, the **Disinfecting** partial cycle is set to DI water (= ON) by default for all reprocessing programs. If only cold water is supplied to the device and the water supply is set to cold water in the **Settings** menu, the process-relevant parameters must be adjusted.

The following must be fulfilled or present:

- ✓ In the menu **Settings > Water > Water supply at DI connection**, **Cold water** is selected, see [DI connection water supply](#) [page 148].
- ✓ The **Service > Parameter > Process relevant parameters** menu is open.

1. Open the desired program (VRP Universal, VRP Universal+ or VRP Intensive).
PLEASE NOTE: Adjustment is not possible for the **Ophthalmic** program.



2. Expand the **Cleaning** partial cycle.

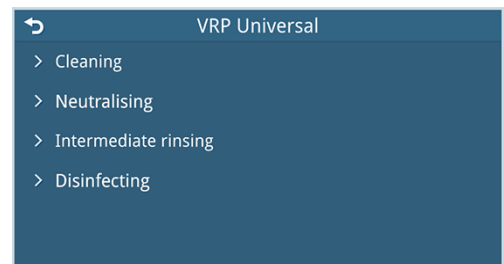

3. In the **DI water** row, press **OFF**.

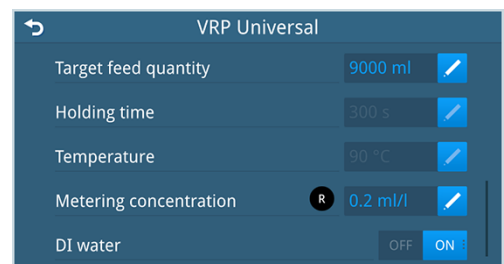

→ The view switches to **OFF ON**.



Trial run

Following the installation, carry out a trial run and record the result in the record of installation.

1. Run the **Universal** or **Ophthalmo** reprocessing program without a load.
2. Check the device and connections for leaks.
3. Record the result in the record of installation.
4. Check the metering quantities of the process agents.
5. Check the temperatures and processes in the program log.

Resetting the maintenance counter

The maintenance counter runs even in device not yet in operation.

- ▶ Reset the maintenance counter, see separate instructions “Resetting the maintenance counter” (doc. AS_020-23).

Validation

Further information on validation of the device can be found in the following documents:

- Recommendation for validation of the MELAtherm 20 (doc. ME_001-24)
- Instructions on how to run validation mode (doc. AS_001-24)

Magnetic pocket for device logbook

The magnetic pocket is used to store the device logbook and is included with the device.

Store the magnetic pocket, including the device logbook, in the immediate vicinity of the device (e.g. in a drawer of an adjacent cabinet). The device logbook must be accessible for maintenance and service work.



Allen key for door emergency opening

The Allen key for the door emergency opening is included with the device.

For rapid access in an emergency, the Allen key is intended to be stored in the device plinth.

1. If necessary, shut down the device.
2. Remove the plinth panel from the front.
3. Insert the Allen key (pos. b) as shown into the housing of the drying fan (pos. a).
4. Insert the plinth panel.

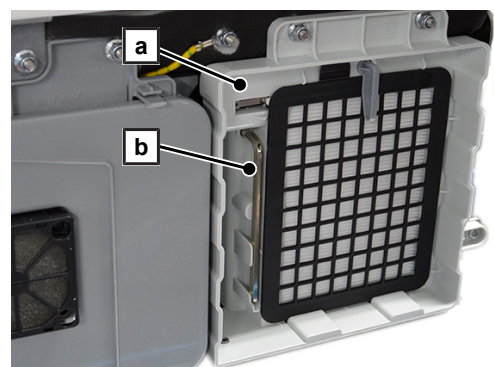



Instructing the users

Explain all user-typical properties for the documentation and setting options for the user in accordance with the record of installation.

The documents included in the scope of delivery (e.g. manufacturer's inspection report) must be kept by the operator. The declaration of conformity of the Medical Device Regulation are included in the manufacturer's inspection report.

7 First steps

Water supply

The [reprocessing](#) of [medical devices](#) requires the use of drinking water in accordance with the local provisions. In Germany, drinking water in accordance with the Drinking Water Ordinance (Trinkwasserverordnung) is required.

The drinking water is supplied on the input side via the building's connection.

The quality of the water used for reprocessing influences the value-retention of the load. In particular, a silicate or chloride burden cannot be removed by the internal water softening unit and lead to the formation of stains and corrosion. In compliance with industry associations (in Germany, for example, [AKI](#), [DGSV](#), [DGKH](#)), MELAG recommends final rinsing with de-ionised water ([DI water](#)).

PLEASE NOTE

The final rinsing and the **Disinfecting** partial cycle mean the same thing in the MELAtherm.

During setup, it is determined whether DI water should be used in final rinsing (**Disinfecting** partial cycle). In addition, depending on customer's specific requirements, the service technician can parametrise the partial cycles precleaning, cleaning, neutralising and intermediate rinsing for DI water. The DI water supply is provided via a water treatment unit (e.g. MELAdem 53/53 C).

PLEASE NOTE: Increased water quality requirements (e.g. low endotoxin burden) may be necessary for the reprocessing of certain medical devices (e.g. in ophthalmology). Note the following:

- In such cases, an additional filter system is required for the reprocessing of DI water. Comply with the specifications of the user documentation of your water treatment unit.
- It is possible that the cold water has been contaminated by the water installation. This includes both the building installation and the entire upstream peripherals.
- Have the actual quality of the cold water tested at the draw-off point or request an appropriate report (e.g. from the building management), before the device is set up and installed.
- Further information is available from the relevant trade associations and their publications. If in doubt, contact your stockist or the competent professional association.

Starting up and shutting down the device

As soon as the device is connected to the mains it is in idle mode. Idle mode means that the device is not ready for operation and most of the control is deactivated.

Press the Power button to start up or shut down the device. The LED of the Power button indicates the device's operating state.

| LED Power button | Operating state |
|------------------|--|
| lights up | The device's power plug is plugged in. The device is not ready for operation. |
| flashes | The device is starting up. The device is not ready for operation. |
| is not lit | The device has been started up. The device is ready for operation or a program is running. |

PLEASE NOTE

Pressing the Power button for longer than 5 s triggers a reset.

Starting up the device

The following must be fulfilled or present:

- ✓ The device is connected to the mains supply and the LED of the Power button is lit.

1. Press the Power button.
The LED of the Power button flashes. The device is starting up.

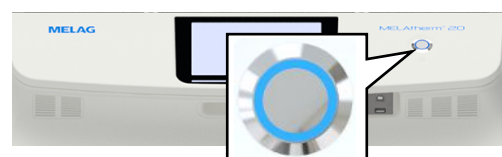

2. Wait until the start screen appears on the display and an acoustic signal sounds.



- ➔ The LED of the Power button is no longer lit.
- ➔ The device is ready for operation.

Shut down the device

While the device shuts down it is placed in idle mode.

The following must be fulfilled or present:

- ✓ No program is run.
 - ✓ There is no log output.
 - ✓ No software update is carried out.
1. Press the Power button and then **YES**.
 2. Wait until the display switches off and an acoustic signal sounds.
- ➔ The LED of the Power button is lit.
 - ➔ The device is in idle mode.

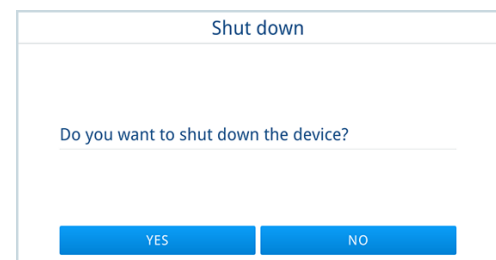

Opening and closing the door

The door is locked and unlocked automatically by a motor.

After a program has run, the door can be opened manually or it opens automatically if automatic door opening is activated.

PLEASE NOTE

The door can only be opened during a program run using a program abort. The door will be unlocked after the program abort has been acknowledged and sufficient cooling has been performed.

Automatic door opening

On delivery, the device's automatic door opening is activated by default, i.e. the door opens automatically after a successfully run program. This function can be deactivated if necessary.

The following must be fulfilled or present:

- ✓ The device is ready for operation.
 - ✓ Automatic door opening is deactivated.
 - ✓ The program run finished successfully.
 - ✓ There is no warning or malfunction message that prevents opening of the door.
1. Wait until the door opens and then press **OK**.
 2. If all the requirements are not met, open the door manually. **NOTICE! Do not allow the door to drop open.**

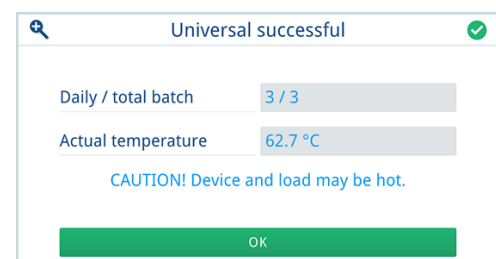

Manual door opening

The door can always be opened manually.

The following must be fulfilled or present:

- ✓ The device is ready for operation.
- ✓ The program run finished/did not finish successfully.
- ✓ There is no warning or malfunction message that prevents opening of the door.

1. Press **OPEN DOOR**.
2. If necessary, enter your user PIN for the authentication.

→ The door is unlocked.

3. Open the door manually.
NOTICE! Do not allow the door to drop open.

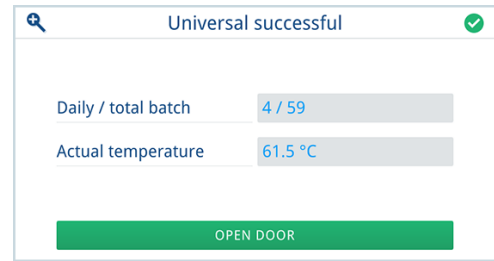

Closing the door

1. Close the door.
NOTICE! Do not slam the door shut.
2. Push the door until the motorised lock catches audibly.

→ The door is locked automatically.

PLEASE NOTE

In case of lengthy operating pauses (at weekends or longer), MELAG recommends leaving the door slightly open so that the door gasket is not permanently under tension.

Inserting the basis baskets into the washing chamber

Inside the washing chamber, on the right-hand side of the rear wall, there are connectors for the water inlet of the middle rinse arm on the upper basket and for the injector rail module in the lower basket.

- a) Connector for the upper basket
- b) Connector for the lower basket with injector rail module

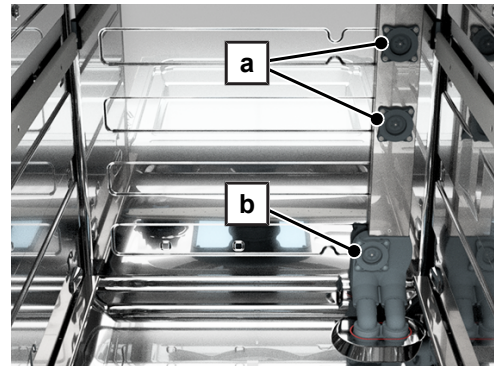

Upper basket

1. Pull the two upper guide rails (pos. e) out of the washing chamber slightly.
2. Position the upper basket (pos. c) in the guide rails (pos. e) at an angle, so that the front two rollers (pos. d) lie against the top and bottom of the rails.

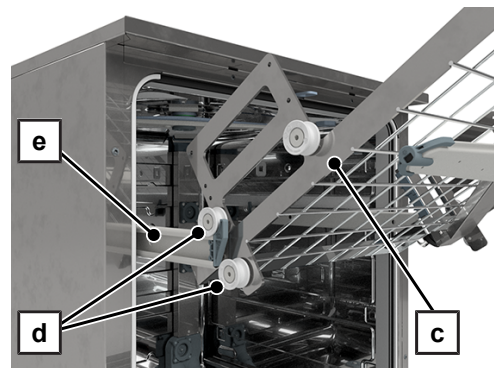

3. Align the upper basket horizontally on the guide rails.
4. Push the upper basket into the washing chamber until the connection fitting docks onto the connector.



Lower basket

1. Place the lower basket (pos. g) on the open door.
2. If present, insert the injector rail module (pos. f) into the lower basket, see [Injector rail module](#) [▶ page 85].
3. Push the lower basket with injector rail module into the washing chamber until the connection fitting of the module docks onto the connector.
Push the lower basket without injector rail module into the washing chamber until it stops.

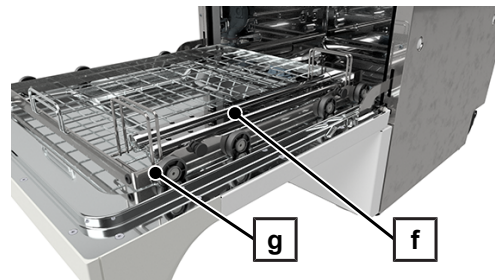

Filling the regenerating salt

NOTICE

Warning of malfunction

Fine-grained regenerating salt can cause malfunctions of the water softening unit. We do not recommend the use of pellets, as the salt dissolves too slowly.

- Use only special, coarse grain regenerating salt (additive-free NaCl), e.g. regenerating salt for MELAtherm.
- Never use table salt, cooking salt, de-icing salt, cattle salt or road salt. These salts usually contain insoluble components.

Filling with regenerating salt for the first time

The regenerating salt is filled for the first time by the ▶[authorised technician](#) during the commissioning of the device.

Refilling regenerating salt

A warning appears on the display if there is no regenerating salt or the level is too low. If the regenerating salt is almost used up, refill it soon. If the regenerating salt is used up, refill it immediately. A program can only be started if there is sufficient regenerating salt in the device.

You can refill regenerating salt at any time without prior warning.

1. If a warning appears on the display, press **OK**.
2. Open the door.
3. Remove the lower basket.
4. Unscrew the screw cap of the salt container by turning it anti-clockwise.
Tip: If the screw cap is screwed on very tight, use the key for 5 l container/salt container to undo the cap.

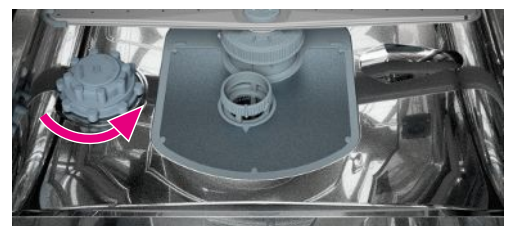

- Place the filling funnel for the regenerating salt on the opening and pour the salt into the salt container via the funnel.



- Remove the filling funnel and any excess salt residue from the washing chamber.



NOTICE

Warning of corrosion

The regenerating salt has a corrosive effect on stainless steel. This can cause damage to the washing chamber and instruments.

- Remove any remaining salt from the washing chamber and make sure that the salt container is tightly closed, to protect the instruments and the device.
- Salt residue on the sealing ring leads to leaks. Ensure that the sealing ring is clean before you screw the cap onto the salt container.

- Screw tight the cap of the salt container manually.
- Insert the lower basket and close the door.
- Confirm the prompt with **YES**.

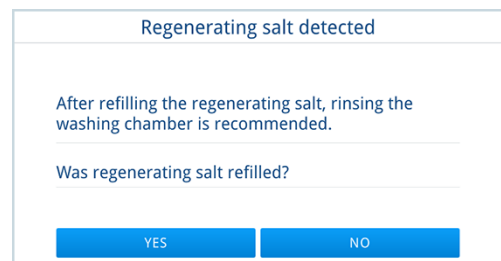

- Start the **Rinsing** service program without (instrument) load.

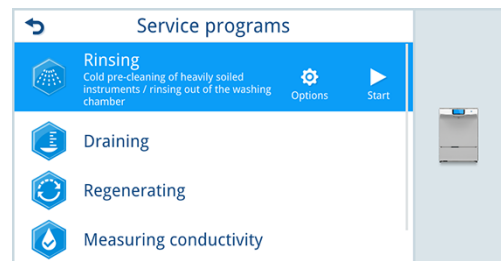

11. Note the program information and confirm with **START PROGRAM**.



12. If necessary, enter your user PIN for the authentication.

Regenerating the water softening unit

The internal water softening unit regenerates automatically at certain intervals. The program run time is extended by a number of minutes. You can regenerate the water softening unit manually, e.g. if you have filled salt without a warning having been issued beforehand.

▶ Start the **Regenerating** service program.

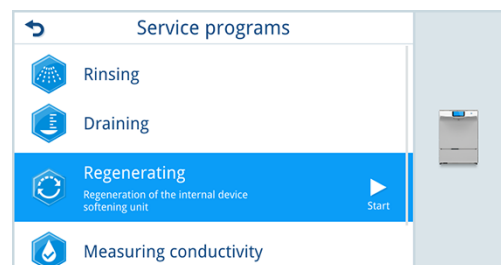

Metering process agents

The concentration of the process agents is set by the ▶**authorised technician** during the commissioning of the device. During the program run, the preset concentration of the relevant process agents is metered automatically.

Holding process agents ready

⚠ CAUTION

Warning of chemical burns from irritant substances

Improper handling of the process agents can lead to chemical burns and health damage.

- Comply with the instructions provided by the manufacturer of the process agents.
- Note that any kind of liquid (e.g. in the floor trough of the device or liquid that leaks from the device) in case of damage can contain aggressive process agents.
- Protect your eyes, hands, clothing and all surfaces from contact with the process agents.

Please note the following:

- Comply with the instructions for use, see [Process agents](#) [▶ page 9].
- De-aerate the metering system before commissioning or after replacing a container, see [De-aerating the metering system](#) [▶ page 54].
- Do not mix ▶**process agents** of different manufacturers when you change the product.

A warning appears on the display if there is no process agent or the level is too low. Replace the process agent container or refill it.

Containers for process agents

Every process agent has its own container and a suction lance with screw-on lid:

- ▶ **Cleaning agent:** 5 l container with a blue suction lance screw-on lid
- ▶ **Neutraliser:** 5 l container with a red suction lance screw-on lid
- ▶ **Rinse aid:** 1 l storage container with black suction lance screw-on lid

PLEASE NOTE

Do not place the process agents above the metering system interface. Gravity will cause the containers and the storage container to empty on their own.

- Do not place the process agents on the device or on a work surface.
- Ensure that the containers and the storage container in an adjacent base cabinet are positioned on the lower level in an adjacent base cabinet.

- ▶ Place the process agents in the immediate vicinity of the device. MELAG recommends using an adjacent base cabinet and the MediaGuard Box, see [Other equipment](#) [▶ page 183].

Replacing the container for the cleaning agent and neutraliser

The following must be fulfilled or present:

- ✓ Key for container lid/salt container for undoing the container lid
- 1. Place the new container next to the empty container.
- 2. Undo the lid of the new container with the help of the key for the 5 l container/salt container. Remove the lid.
- 3. Unscrew the suction lance from the old container and screw this suction lance onto the new container.
- 4. De-aerate the metering line of the cleaning agent and/or neutraliser, see [De-aerating the metering system](#) [▶ page 54].

Refilling the storage container for rinse aid

WARNING

Warning of eye damage from rinse aid

▶ **Rinse aid** may not be used for ▶ [reprocessing](#) ophthalmologic instruments, see [Reprocessing ophthalmological instruments](#) [▶ page 125].

PLEASE NOTE

Visible streaks on the instruments can be caused by overmetering of the rinse aid.

The following must be fulfilled or present:

- ✓ Clean, lint-free surface (e.g. paper towel)
- 1. Unscrew the suction lance from the 1 l storage container and place the suction lance on a clean, lint-free surface.
- 2. Transfer the rinse aid from the original packaging into the MELAG 1 l storage container.
 - ↳ Fill the 1 l storage container up to the $\frac{3}{4}$ level only, so that the rinse aid does not overflow when the suction lance is inserted.
- 3. Screw the suction lance onto the storage container.
- 4. De-aerate the metering line of the rinse aid, see [De-aerating the metering system](#) [▶ page 54].

MediaGuard Box

The MediaGuard Box is used to store the process agents. If process agents leak they remain safely in the box.

The MediaGuard Box is not included with the device, see [Other equipment](#) [▶ page 183].

Setting up the MediaGuard Box

The initial setup of the MediaGuard Box is carried out by an ▶ [authorised technician](#).

Replacing the container for the cleaning agent and neutraliser

⚠ CAUTION

Warning of chemical burns from irritant substances

Improper handling of the process agents can lead to chemical burns and health damage.

- Comply with the instructions provided by the manufacturer of the process agents.
- Protect your eyes, hands, clothing and all surfaces from contact with the process agents.

The following must be fulfilled or present:

- ✓ Key for container lid/salt container for undoing the container lid
- 1. Unscrew the suction lance (pos. b) from the old container and hook the suction lance into the suction lance bracket (pos. a).
- 2. Remove the old container from the box.
- 3. Undo the lid of the new container with the help of the key for the 5 l container/salt container. Remove the lid.
- 4. Place the new container in the box and screw on the suction lance. Make sure the suction lance is positioned at the lowest point of the box.
- 5. De-aerate the metering line of the cleaning agent and/or neutraliser, see [De-aerating the metering system](#) [▶ page 54].

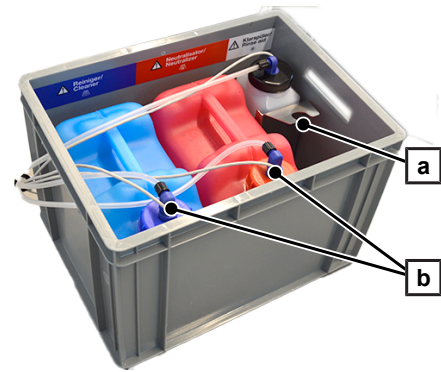

Refilling the storage container for rinse aid

- 1. Unscrew the suction lance (pos. c) from the storage container and hook the suction lance into the suction lance bracket (pos. a).
- 2. Transfer the rinse aid from the original packaging into the MELAG 1 l storage container.
 - ↳ Fill the 1 l storage container up to the ¾ level only, so that the rinse aid does not overflow when the suction lance is inserted.
- 3. Screw the suction lance onto the storage container.
- 4. De-aerate the metering line of the rinse aid, see [De-aerating the metering system](#) [▶ page 54].

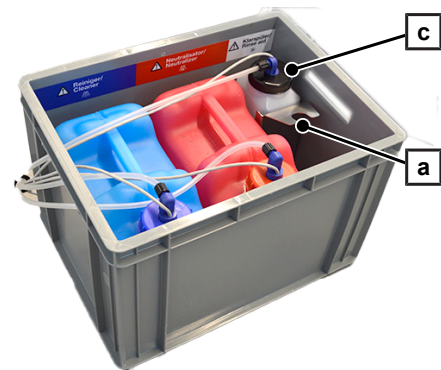

Product change

When you change the product, i.e. want to use the process agent of another manufacturer, the metering system must be rinsed before using the new product for the first time.

⚠ CAUTION

Warning of chemical burns from irritant substances

Improper handling of the process agents can lead to chemical burns and health damage.

- Comply with the instructions provided by the manufacturer of the process agents.
- Protect your eyes, hands, clothing and all surfaces from contact with the process agents.

The following must be fulfilled or present:

- ✓ The old process agents have been used up.
- ✓ Container (5 l)
- ✓ Key for container lid/salt container for undoing the container lid
- 1. Place the suction lances in a 5 l container with water.
- 2. Start the **Rinsing** service program without (instrument) load.
- 3. Note the program information **Service program without reprocessing** and confirm with **START PROGRAM**.

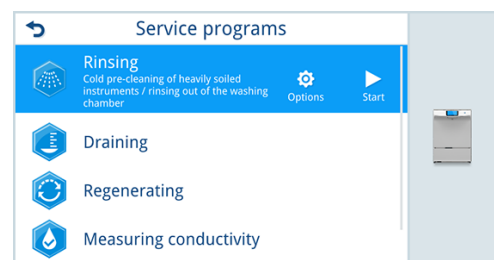

4. Start the **Air removal** service program.
5. Note the program information **Service program without reprocessing** and confirm with **START PROGRAM**.

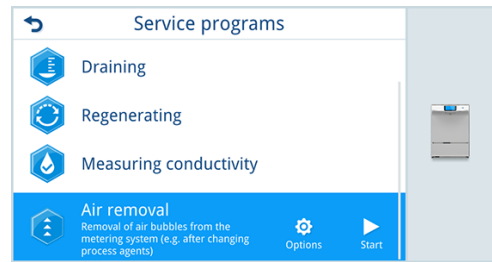

6. Carefully rinse the 1 l storage container for the rinse aid with clean water.
7. Replace the 5 l container for cleaning agent and neutraliser and fill the 1 l storage container of the rinse aid, see [Containers for process agents](#) [▶ page 52].
8. De-aerate the metering system, see [De-aerating the metering system](#) [▶ page 54].
9. Dispose of any remaining quantities of the process agents according to the instructions in the safety data sheets. The safety data sheets for Metherm can be found on the MELAG website: <https://www.melag.com/sds>

De-aerating the metering system

The metering system must be de-aerated during commissioning, after removing the suction lances or before the first reprocessing program. De-aeration completely removes all air bubbles pockets from the hoses and ensures fault-free metering.

The following must be fulfilled or present:

- ✓ The **Service programs** menu is open.

1. Select **Air removal** and press **Start**. **PLEASE NOTE:** If **start** is not displayed, no metering pumps have been selected for de-aeration. Press **Options** and make the setting, see [Air removal program options](#) [▶ page 54].

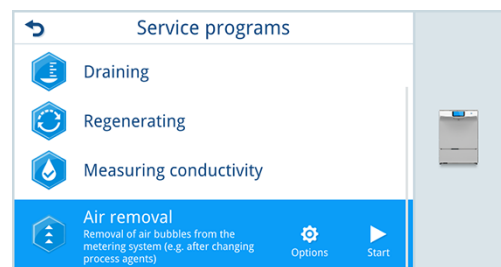

2. Note the program information and confirm with **START PROGRAM**.

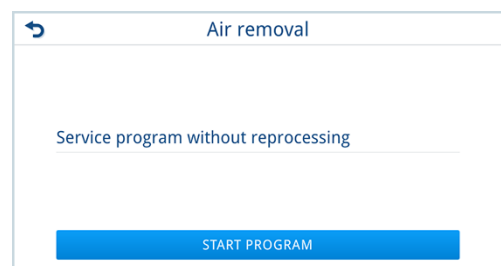

3. If necessary, enter your user PIN for the authentication.

Air removal program options

In the program options, you can choose which metering line is to be de-aerated or not de-aerated. In ophthalmology, no rinse aid is required; that is, the rinse aid metering line can be deselected.

1. Press .



2. Select **Air removal** or **Do not remove air** and press **OK**.

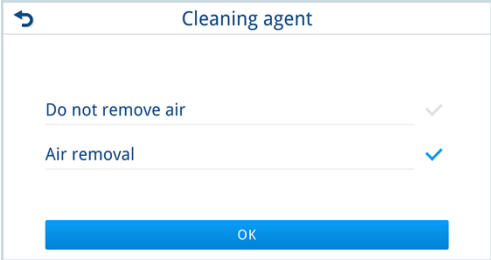

← Cleaning agent

Do not remove air ✓

Air removal ✓

OK

3. Press **START PROGRAM**.



← Air removal

Cleaning agent Air removal ✓

Neutraliser Air removal ✓

Rinse aid Air removal ✓

START PROGRAM

8 Components for reprocessing

Comply with the following for safe handling:

- Use original MELAG components. If using third-party components or MELAG ▶components not named in the following, the operator must ensure and verify their suitability. We cannot provide a guarantee for non-MELAG components, even if they have been validated.
- When using additional components of other manufacturers to hold instruments, especially hollow-body instruments, follow the instructions in the operating manual provided by the component manufacturer.
- Use all components only for their intended purpose and for the respective described instruments.
- Note that components of other manufacturers must be temperature resistant up to 95 °C and resistant to the ▶process agents used.
- Before using the components for the first time, check them for manufacturing residues and damage. Clean the components in the washer-disinfector. To do so, run the **Rinsing** service program without a ▶load.

Use of tools

If tools (e.g. a size 10 open-end spanner) is needed for the use of ▶components, then use tools made of CrV steel.

To avoid damage to the components, only use tools if specified within the scope of the application. Do not use damaged components for the reprocessing.

Disposal

Dispose of ▶components, if they show severe signs of wear (e.g. abrasion, cracks or corrosion) or damage (e.g. deformation).

Reprocess the components to be disposed of in isolation in the washer-disinfector before disposing of them.

Basis baskets

The following views are not to scale.

Upper basket



Lower basket

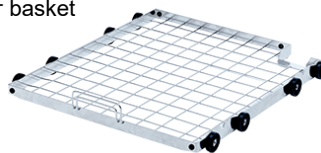

The upper and lower basket form the basis for each loading variant. All components for the reprocessing are placed in these basis baskets. Depending on the area of application, they can be loaded with any combination of holders, instrument baskets, etc. Examples of the basic configuration can be found in [Examples for the basic configuration](#) [▶ page 118].

Used with

| Category | Article | |
|---|----------------------|------------------|
| Injector rail | Injector rail module | for Lower basket |
| See also Components [▶ page 180]. | | |

Holders

The following views are not to scale.

Universal holder Flex 1

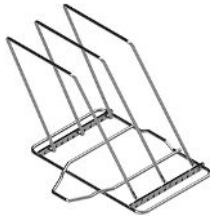

Universal holder Flex 2



Universal holder Flex 3

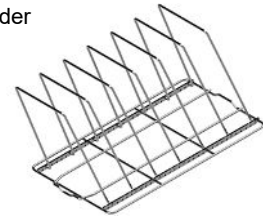

Universal holder Flex 4

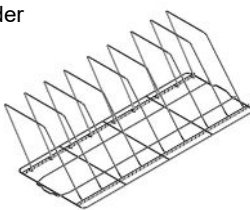

Bracket for universal holder



Universal holder Flex 1 (low)

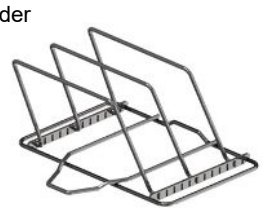

Universal holder Flex 2 (low)

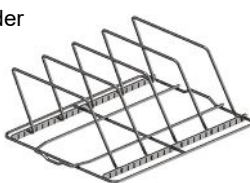

Universal holder Flex 3 (low)

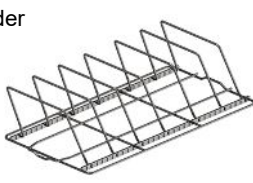

Universal holder Flex 4 (low)

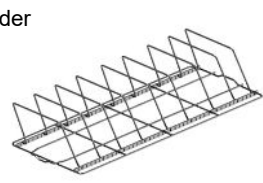

Bracket for Universal holder (low)



Holder for 5 trays / 10 half trays

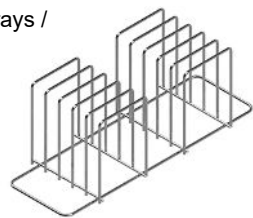

Please note the following:

- Only reprocess instrument trays which are approved by the manufacturer for reprocessing in a washer-disinfector. If required, request the reprocessing instructions from the respective manufacturer.
- Follow the permissible loading instructions for the holders.

Universal holder Flex 1-4

The universal holder Flex can be used to hold MELAstore Trays, trays and kidney dishes. The universal holder Flex is not stackable.

| Universal holder | Max. number of MELAstore Trays per holder | | | | | | |
|------------------|---|----------------------------------|--------------------|--------------------|------------------------------|------------|-------|
| | MELAstore Tray 33 ^{*)} | MELAstore Tray 50 ^{**)} | MELAstore Tray 100 | MELAstore Tray 200 | MELAstore Tray Ophthalmology | | |
| | | | | | Upper part | Lower part | light |
| Flex 1 | 6x | 4x | 2x | 1x | 2x | 2x | 2x |
| Flex 2 | 12x | 8x | 4x | 3x | 4x | 4x | 4x |
| Flex 3 | 18x | 12x | 6x | 5x | 6x | 6x | 6x |
| Flex 4 | 27x | 16x | 8x | 7x | 8x | 8x | 8x |

^{*)} three each stacked on top of each other | ^{**)} two each stacked on top of each other

1. Insert the required number of brackets (pos. a) into the base (pos. b) from the inside.
 - ➔ Choose a sufficiently large distance between the brackets to ensure proper rinsing of the load.
 - ➔ Make sure that you insert the brackets at the same height on both sides of the base.
 - ➔ Make sure that the brackets are tilted towards the base support (pos. c) to prevent the universal holder from tipping over.
2. Insert the universal holder into the washing chamber so that the brackets are inclined towards the device door.

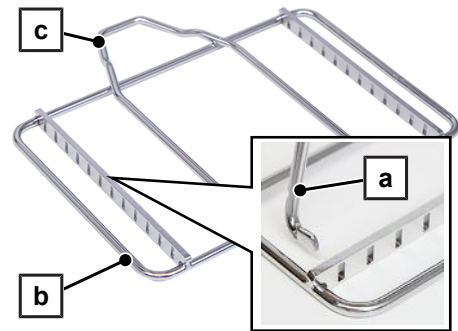

Place the **MELAstore Trays** in the holder with the closure pointing to the rear. For easier loading and removal, the MELAstore Trays should be inclined towards the device door.

Remove coarse soiling from the **instrument trays** before reprocessing in the device. Place several trays in the holder with the recess pointing in the same direction.



Used with

| Category | Article |
|---|--|
| Basis baskets | Lower basket |
| MELAstore Tray and silicone bars | MELAstore Tray 33 (8.4 x 17.9 x 3.2 cm) |
| | MELAstore Tray 50 (17.9 x 12.8 x 3.2 cm) |
| | MELAstore Tray 100 (28 x 17.9 x 3.2 cm) |
| | MELAstore Tray 200 (28 x 17.9 x 4.3 cm) |
| | MELAstore Tray Ophthalmology |
| | MELAstore Tray Ophthalmology light |
| Spare parts | Bracket for universal holder |
| See also Components [▶ page 180]. | |

Universal holder Flex 1-4 (low)

The universal holder Flex (low) can be used to hold the MELAstore Tray 33 and 50. The universal holder Flex (low) is not stackable.

| Universal holder | Max. number of MELAstore Trays per holder | |
|--|---|-------------------|
| | MELAstore Tray 33 ^{*)} | MELAstore Tray 50 |
| Flex 1 (low) | 4x | 2x |
| Flex 2 (low) | 8x | 4x |
| Flex 3 (low) | 12x | 6x |
| Flex 4 (low) | 16x | 8x |
| ^{*)} two stacked on top of each other | | |

1. Insert the required number of brackets (pos. a) into the base (pos. b) from the inside.
 - ↳ Choose a sufficiently large distance between the brackets to ensure proper rinsing of the load.
 - ↳ Make sure that you insert the brackets at the same height on both sides of the base.
 - ↳ Make sure that the brackets are tilted towards the base support (pos. c) to prevent the universal holder from tipping over.
2. Insert the universal holder into the washing chamber so that the brackets are inclined towards the device door.

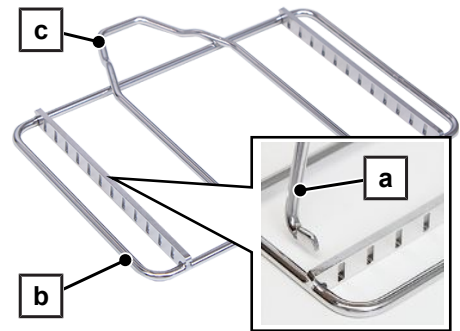

Place the **MELAstore Trays** in the holder with the closure pointing to the rear. For easier loading and removal, the MELAstore Trays should be inclined towards the device door.



Used with

| Category | Article |
|---|--|
| Basis baskets | Upper basket |
| | Lower basket |
| MELAstore Tray and silicone bars | MELAstore Tray 33 (8.4 x 17.9 x 3.2 cm) |
| | MELAstore Tray 50 (17.9 x 12.8 x 3.2 cm) |
| Spare parts | Bracket for Universal holder (low) |
| See also Components [▶ page 180]. | |

Holder for trays (5 pcs.)/half trays (10 pcs.)

The holder is used to hold instrument trays with a maximum height of 20 mm. The holder is not stackable.

Depending on the size, 5 to 10 instrument trays can be placed in the holder.

1. Remove coarse soiling from the trays before reprocessing in the device.
2. Place several instrument trays in the holder with the recess pointing in the same direction.



Used with

| Category | Article |
|---|--------------|
| Basis baskets | Lower basket |
| See also Components [▶ page 180]. | |

Instrument baskets

The following views are not to scale.

Instrument basket G

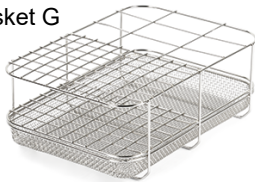

Instrument basket compact

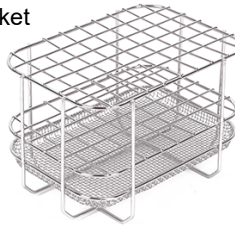

Instrument basket standard



Tip protection for instrument basket



Instrument basket G, compact and standard

The instrument basket is used for reprocessing upright instruments e.g. tweezers, probes, mirrors, scissors, clamps, nasal specula, etc. The instrument basket cannot be stacked.

Universal dental suction cannulas with 11 mm and 16 mm connections can be reprocessed in instrument baskets in an upright position. The distal end must point upwards. This must be considered separately during validation.

⚠ CAUTION

Warning of injury

The loading and unloading of pointed and sharp instruments can cause injuries if not handled properly.

- Wear suitable hand protection to avoid injuries during loading and unloading.

📌 PLEASE NOTE

Instruments must be disassembled for reprocessing according to the manufacturer's instructions.

1. Remove heavy soiling on the instruments, such as adhering dental cement or similar materials, immediately after use on the patient.
2. Remove dried-on residues in an ultrasonic bath.
3. Place the instrument basket in a basis basket.
4. Insert all mirrors and other sensitive instruments in the instrument basket in such a way that they do not cover each other or become damaged by hitting other instruments.
5. Place the instruments in the instrument basket with the grip ends facing downwards.

PLEASE NOTE: Where instruments have two working ends, MELAG recommends use of the tip support.



Used with

| Category | Article |
|---|--------------------------------------|
| Basis baskets | Upper basket |
| | Lower basket |
| Instrument baskets | Tip protection for instrument basket |
| See also Components [▶ page 180]. | |

Tip protection for instrument basket

The tip support prevents tips from slipping through or piercing the wire mesh of the instrument basket.

- ▶ Hook the tip support into the lower level of the instrument basket lengthwise.

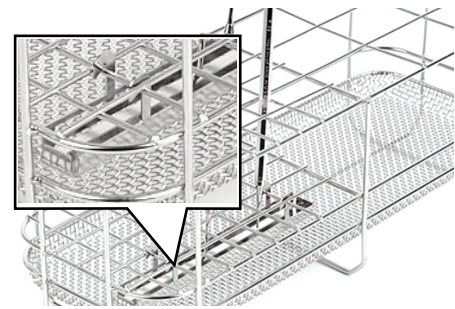

Used with

| Category | Article |
|---|----------------------------|
| Instrument baskets | Instrument basket G |
| | Instrument basket compact |
| | Instrument basket standard |
| See also Components [▶ page 180]. | |

Small parts basket

The following views are not to scale.

Small parts basket Standard



Small parts basket Comfort

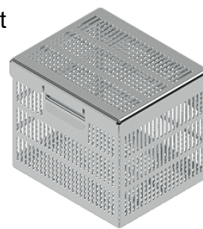

Bur holder

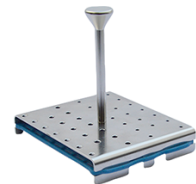

Silicone mesh for bur holder (2 pcs)

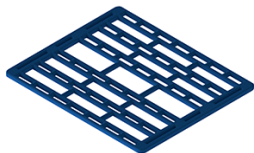

⚠ CAUTION

Warning of injury

The loading and unloading of pointed and sharp instruments can cause injuries if not handled properly.

- Wear suitable hand protection to avoid injuries during loading and unloading.

📌 PLEASE NOTE

For particularly sensitive instruments such as endo instruments, MELAG recommends using the ▶[components](#) for ▶[reprocessing](#) provided by the manufacturer.

Small parts basket Standard

The standard small parts basket is used for safe reprocessing of small instruments (e.g. burs) to prevent them from being lost in the washing chamber or blocking the openings in the washing chamber.

1. Load the small parts basket with small instruments (e.g. burs) and lock the two half-shells with the catch (pos. a).
2. Lay or place the small parts basket in the instrument or Flex baskets.



Used with

| Category | Article |
|---|----------------------------|
| Instrument baskets | Instrument basket G |
| | Instrument basket compact |
| | Instrument basket standard |
| Stackable holders and baskets (Flex system) | Flex basket 1-4 |
| | Flex supplementary basket |
| See also Components [▶ page 180]. | |

Komfort small parts basket

The Komfort small parts basket is used to hold unordered small instruments (e.g. burs) or to load it with the bur stand.

1. Load the Komfort small parts basket with small, unordered instruments (e.g. burs).
2. Close the lid.
3. Place the Komfort small parts basket in the Flex basket 1, 2 or 3.



Used with

| Category | Article |
|---|-----------------|
| Basis baskets | Upper basket |
| | Lower basket |
| Stackable holders and baskets (Flex system) | Flex basket 1-8 |
| Small parts basket | Bur holder |
| See also Components [▶ page 180]. | |

Bur holder

The bur holder is used to safely hold up to 38 rotating instruments (e.g. burs) with shank diameters of 1.6 mm and 2.35 mm (up to 19 each). The rotating instruments are fixed by a silicone mesh underneath the bur holder, see [Silicone mesh for bur holder](#) [▶ page 63].

The Komfort small parts basket in combination with the bor stand is used for ordered holding of rotating instruments.

Before reprocessing:

1. First load the bur holder with short and then long instruments. For orderly loading, place the instruments with the shank first into the matching opening as far as it will go.
2. Place the bor stand in the Komfort small parts basket and close the basket with the lid.
3. Place the Comfort small parts basket in the Flex basket 1, 2 or 3.

After reprocessing:

- ▶ Remove the long instruments first and then the short instruments.

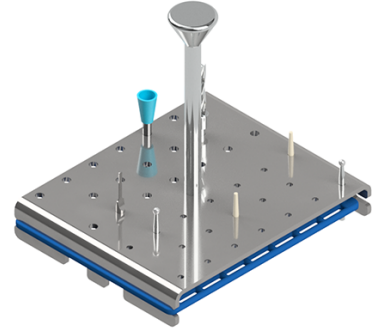

Used with

| Category | Article |
|---|--------------------------------------|
| Small parts basket | Small parts basket Comfort |
| Spare parts | Silicone mesh for bur holder (2 pcs) |
| See also Components [▶ page 180]. | |

Silicone mesh for bur holder

The rotating instruments are fixed in the bor stand from below by the silicone mesh.

Routine check

1. Check the silicone mesh regularly for damage.
2. Replace the silicone mesh if necessary.

Replacing the silicone mesh

1. Reprocess the Komfort small parts basket including bor stand and the old silicone mesh automatically.
2. Wait until the ▶components have cooled sufficiently after successful reprocessing.
3. Detach the outer meshes (pos. a) on both sides of the old silicone mesh from the tensioning tabs (pos. b) of the bur holder.
4. Rinse the new silicone mesh under running water.
5. Clamp the new silicone mesh under the bur holder. Pay attention to the alignment of the silicone mesh. The mesh sizes of the silicone mesh must correspond to the hole sizes in the bur holder.

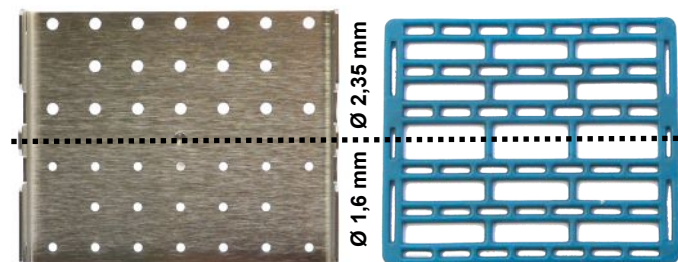
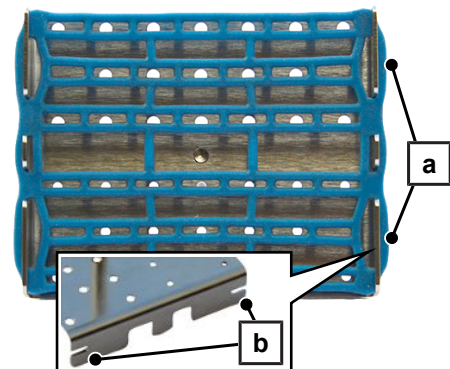

- ▶ The large meshes of the silicone mesh must be below the large holes (shank diameter 2.35 mm) of the bur holder.
- ▶ The small meshes of the silicone mesh must be below the small holes (shank diameter 1.6 mm) of the bur holder.

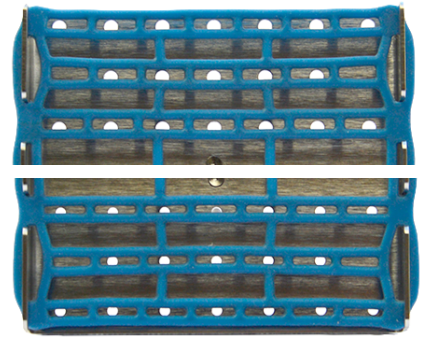

Used with

| Category | Article |
|---|------------|
| Small parts basket | Bur holder |
| See also Components [▶ page 180]. | |

Stackable holders and baskets

The following views are not to scale.

Flex basket 1



Flex basket 2



Flex basket 3



Flex basket 4



Flex basket 6

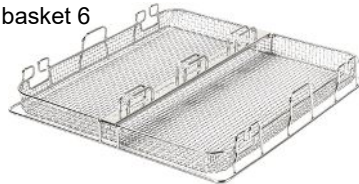

Flex basket 8



Flex basket specula

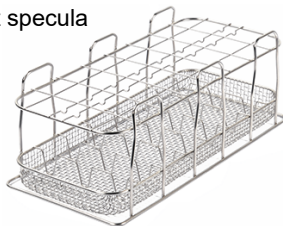

Flex supplementary basket



Holder for impression trays and instruments with joints

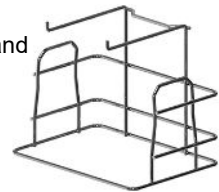

Instrument holder for Flex baskets



CAUTION

Warning of injury

The loading and unloading of pointed and sharp instruments can cause injuries if not handled properly.

- Wear suitable hand protection to avoid injuries during loading and unloading.

PLEASE NOTE

To optimise the cleaning result, reprocess hinged instruments such as scissors and clamps in the holders provided, see [Holder for hinged instruments and impression trays](#) [▶ page 68].

Flex basket 1-4

The Flex baskets are used to process instruments laying flat (positioned horizontally), e.g. tweezers, mirrors, scissors, etc.

1. Place the Flex basket in a basis basket.
2. Stack the Flex basket with a maximum of two levels.

You can additionally use top frames for stackable Flex baskets.



Used with

| Category | Article | |
|--|--|---------------------|
| Basis baskets | Upper basket | -- |
| | Lower basket | -- |
| Stackable holders and baskets (Flex system) | Flex basket 6 | for Flex basket 1-3 |
| | Flex basket 8 | for Flex basket 1-4 |
| Top frames for stackable baskets (Flex system) | Top frame for ear specula Flex 1 (mesh size 14 mm) | -- |
| | Top frame for ear specula Flex 1 (mesh size 20 mm) | -- |
| | Top frame for ear specula Flex 2 (mesh size 20 mm) | -- |
| | Top frame for ear specula Flex 3 (mesh size 20 mm) | -- |

See also [Components](#) [▶ page 180].

Flex basket 6

Flex basket 6 is used for the reprocessing of long instruments up to a length of 40 cm lying flat, e.g. cannulas, tweezers, scissors, trocars, suitable endoscopy accessories, etc.

Flex basket 6 can be used as a basis under the Flex baskets 1, 2, 3 and under the Flex basket specula.

- ▶ Lay the hoses without kinks and sags, preferably by using the hose grommet.
- NOTICE! Do not pinch off the hoses with further Flex baskets.**



Used with

| Category | Article |
|---|---|
| Basis baskets | Upper basket |
| | Lower basket |
| Stackable holders and baskets (Flex system) | Flex basket 1 |
| | Flex basket 2 |
| | Flex basket 3 |
| | Flex basket specula |
| | Holder for impression trays and instruments with joints |
| | Instrument holder for Flex baskets |
| Distributor | Injector basket Flex 1 |

See also [Components](#) [▶ page 180].

Flex basket 8

Flex basket 8 is used for the reprocessing of long instruments lying flat, e.g. cannulas, tweezers, scissors, trocars, suitable endoscopy accessories, etc.

Flex basket 8 can be used as a basis basket under Flex baskets 1-4 and under the Flex basket specular and the supplementary basket.

- ▶ Lay the hoses without kinks and sags, preferably by using the hose grommet.

NOTICE! Do not pinch off the hoses with further Flex baskets.

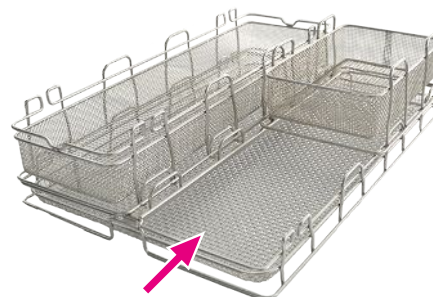

Used with

| Category | Article |
|---|---|
| Basis baskets | Upper basket |
| | Lower basket |
| Stackable holders and baskets (Flex system) | Flex basket 1-4 |
| | Flex basket specula |
| | Flex supplementary basket |
| | Holder for impression trays and instruments with joints |
| | Instrument holder for Flex baskets |
| Distributor | Injector basket Flex 1 |
| See also Components [▶ page 180]. | |

Flex basket specula

The Flex basket specula is used for the reprocessing of up to 8 Kristeller specula or 16 Cusco/Semm specula.

Up to 2 Flex baskets specula have space next to each other on the Flex basket 6.

- ▶ Place the Flex basket specula in a basis basket.



Instructions for Kristeller specula

The arches in the longitudinal struts of the standard instrument basket serve on the one hand as a centre fixation and on the other hand as a separating device.

1. Position each wide Kristeller specula so that it is fixed in the basket with the help of an arch.
2. Position each of the narrow Kristeller specula next to an arch to fix them separately in the basket.



3. Increase the inclination for short instruments to achieve better drainage. To do this, place the ends of the Kristeller against the longitudinal strut at the bottom of the standard instrument basket.

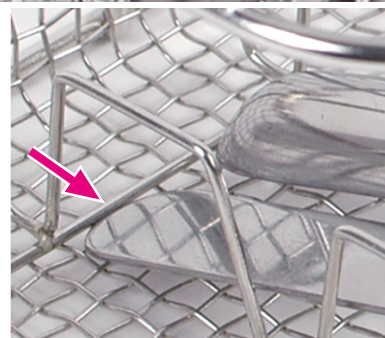

Instructions for Cusco/Semm specula

- ▶ Hang the Cusco specula spread and over the longitudinal struts.



Used with

| Category | Article |
|---|---------------|
| Basis baskets | Upper basket |
| | Lower basket |
| Stackable holders and baskets (Flex system) | Flex basket 6 |
| | Flex basket 8 |
| See also Components [▶ page 180]. | |

Flex supplementary basket

The Flex supplementary basket is used for the reprocessing of instruments lying flat, e.g. tweezers, mirrors, scissors, etc.

1. Place the supplementary basket in a basis basket.
2. Stack the supplementary basket with a maximum of two levels.

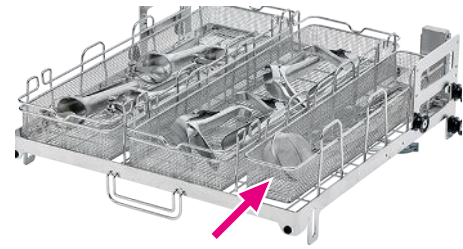

Used with

| Category | Article |
|---|--------------|
| Basis baskets | Upper basket |
| | Lower basket |
| See also Components [▶ page 180]. | |

Holder for hinged instruments and impression trays

The holder is used for the reprocessing of up to 8 impression trays used in the dental sector and for the reprocessing of scissors, clamps and similar hinged instruments.

The holder containing longer scissors, clamps and similar hinged instruments can be stacked above Flex baskets 1-8.



1. Hang the impression trays one after the other on the hooks.
2. Hang the scissors, clamps and similar hinged instruments spread and with the processing end facing downwards in the mount or place them on the brackets.
3. Place the holder in a basis basket.



PLEASE NOTE

Long pointed objects can push through the basis basket, thus blocking the rinse arm.

- Ensure that the rinse arm can turn. If necessary, divide up the instruments into other Flex baskets.

Used with

| Category | Article |
|---|-----------------|
| Basis baskets | Upper basket |
| | Lower basket |
| Stackable holders and baskets (Flex system) | Flex basket 1-8 |
| See also Components [▶ page 180]. | |

Instrument holder for Flex baskets

The instrument holder is used for ordered holding of instruments in the washing basket and provides a secure hold during cleaning. This avoids a situation in which the instruments slide around in the washing basket, thereby causing damage. This also improves the drying of the instruments. Hinged instruments can be held continuously open.

A minimum of two instrument holders are required per instrument. Multiple instrument holders may be required for hinged instruments.

1. If necessary, you can twist or cut off individual instrumental holders from the row (of 6, pos. a) and insert them in the washing basket separately.
2. Insert the instrument holders individually in the washing basket. Press the feet (pos. b) of the instrument holders individually into the mesh of the washing basket.
3. An instrument holder has two levels for instrument acceptance. Only fill a single level with an instrument at any one time.
 - ➔ Place instruments with a diameter of 3-6 mm in level 1 (top).
 - ➔ Place instruments with a diameter of 6-12 mm in level 2 (bottom).

▶ Replace instrument holders if they are visibly worn or damaged.

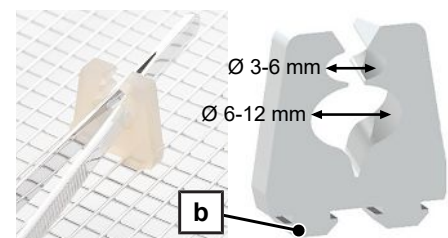
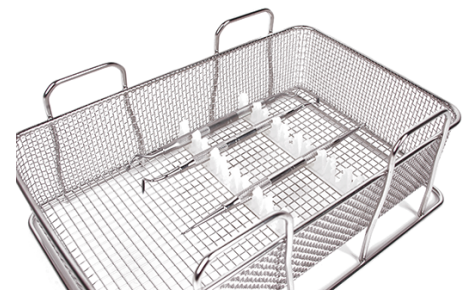

Used with

| Category | Article |
|---|-----------------|
| Stackable holders and baskets (Flex system) | Flex basket 1-8 |
| See also Components [▶ page 180]. | |

Top frames for stackable baskets (Flex system)

The following views are not to scale.

Top frame for ear specula Flex 1 (mesh size 20 mm)



Top frame for ear specula Flex 1 (mesh size 14 mm)



Top frame for ear specula Flex 2 (mesh size 20 mm)



Top frame for ear specula Flex 3 (mesh size 20 mm)



Top frame for nasal specula Flex 1 incl. 2 fixing clamps



Fixing clamp for top frames

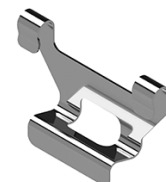

Top frame for ear specula Flex 1-3

The top frames are used in combination with a flex basket for the reprocessing of ear specula.

You can use the top frame with Flex baskets 1, 2 or 3 as you like, partly equipped or overlapping, see [The Flex system](#) [▶ page 118].

| Top frame for ear specula | Number of top frames Flex basket Max. number of ear specula | | | |
|---------------------------|---|---------------|---------------|---------------|
| | Flex basket 1 | Flex basket 2 | Flex basket 3 | Flex basket 4 |
| Flex 1 (mesh size 14 mm) | 1x 50 pcs. | 2x 100 pcs. | 3x 150 pcs. | 4x 200 pcs. |
| Flex 1 (mesh size 20 mm) | 1x 24 pcs. | 2x 48 pcs. | 3x 66 pcs. | 4x 90 pcs. |
| Flex 2 (mesh size 20 mm) | -- | 1x 60 pcs. | 1x 60 pcs. | 2x 120 pcs. |
| Flex 3 (mesh size 20 mm) | -- | -- | 1x 96 pcs. | 1x 96 pcs. |

1. Place the top frame (pos. a) on a Flex basket.
 2. If required, fix the top frame in place with fixing clamps, see [Fixing clamps for top frame](#) [▶ page 71].
 3. Hang the ear specula (pos. b) with the pointed side facing downwards in the spaces.
- PLEASE NOTE:** Ensure that the ear specula do not come into contact with each other.

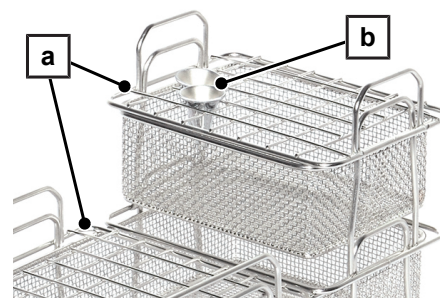

Used with

| Category | Article |
|---|-----------------------------|
| Stackable holders and baskets (Flex system) | Flex basket 1-4 |
| | Fixing clamp for top frames |
| See also Components [▶ page 180]. | |

Top frame for nasal specula Flex 1 incl. 2 fixing clamps

The top frame in combination with a Flex basket is used for the reprocessing of, e.g. nasal specula.

You can reprocess 9 to 12 nasal specula per top frame, depending on the size.

| Top frame for nasal specula | Max. number of top frames per Flex basket | | | |
|-----------------------------|---|---------------|---------------|---------------|
| | Flex basket 1 | Flex basket 2 | Flex basket 3 | Flex basket 4 |
| Flex 1 | 1x | 2x | 3x | 4x |

1. Place the top frame on a Flex basket and fix it with the fixing clamps, see [Fixing clamps for top frame](#) [▶ page 71].
2. Place the nasal specula with the grip ends in the spaces so that the working ends are open.



Used with

| Category | Article |
|---|-----------------------------|
| Stackable holders and baskets (Flex system) | Flex basket 1-4 |
| | Fixing clamp for top frames |
| See also Components [▶ page 180]. | |

Fixing clamps for top frame

The fixing clamps are used to fix the Flex top frames on the Flex basket.

1. Hook the brackets of the fixing clamp from the inside into the handle of the top frame.
2. Press the fixing clamp under the handle of the Flex basket.



Used with

| Category | Article |
|---|-----------------|
| Stackable holders and baskets (Flex system) | Flex basket 1-4 |
| Top frames for stackable baskets (Flex system) | all |
| See also Components [▶ page 180]. | |

MELAstore Tray and silicone bars

The following views are not to scale.

MELAstore Tray 33
(8.4 x 17.9 x 3.2 cm)



MELAstore Tray 50
(17.9 x 12.8 x 3.2 cm)

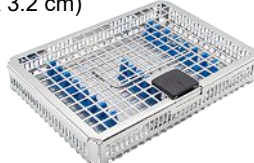

MELAstore Tray 100
(28 x 17.9 x 3.2 cm)

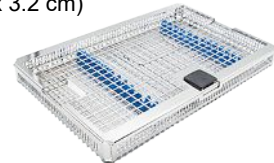

MELAstore Tray 200
(28 x 17.9 x 4.3 cm)



MELAstore Tray Ophthalmology



MELAstore Tray Ophthalmology light



Protective cover
MELAstore Tray OTS /
Lid OTS light

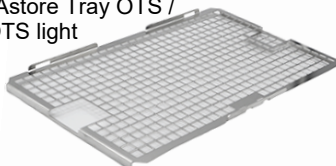

Silicone bar, MELAstore Tray Ophthalmology/100/50/33



Silicone bar, MELAstore Tray 200

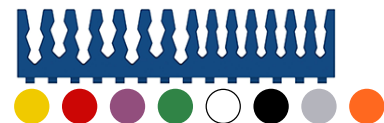

Please note the following:

- Cheek retractors can only be reprocessed in the MELAstore Tray 100 or 200.
- Do not reprocess any hollow-body instruments in MELAstore Tray 33, 50, 100 and 200.
- Instruments should only be reprocessed fixed in the trays. Use silicone bars for this. Follow the relevant instructions for use of the silicone bars, see [Silicone bars](#) [▶ page 85].
- Observe the following instructions for using the MELAstore Trays in the holder, see [Holders](#) [▶ page 57].

MELAstore Tray 33, 50, 100 and 200

The MELAstore Tray is used for the reprocessing of thermostable solid instruments in the MELAtherm. After reprocessing in the MELAtherm, the MELAstore Tray together with instruments can be sterilized, stored and transported using a MELAstore Box. Comply with the application usage advice of the MELAstore Box 100 and 200.

1. Insert the silicone bars as required, see [Silicone bars](#) [▶ page 85].
2. Insert cheek retractors into MELAstore Tray 100/200 so that the handle fits through the recess in the lid when the tray is closed.
3. Load the MELAstore Tray correctly for rinsing (e.g. hinged instruments opened, no loading over each other).
4. Insert large area instruments in such a way as to prevent unwashed areas on other instruments.
5. Place the closed MELAstore Tray in the suitable holder, see [Universal holder Flex 1-4](#) [▶ page 57].



Used with

| Category | Article | |
|----------------------------------|--|---------------------------|
| MELAstore Tray and silicone bars | Mount identification plate for MELAstore Tray | -- |
| | Silicone bars for MELAstore Tray Ophthalmology/100/50/33 | -- |
| | Silicone bars for MELAstore Tray 200 | -- |
| Holders | Universal holder Flex 1-4 | -- |
| | Universal holder Flex 1-4 (low) | only MELAstore Tray 33/50 |





See also [Components](#) [▶ page 180].







MELAstore Tray Ophthalmology

The MELAstore Tray Ophthalmology is used for reprocessing thermostable solid instruments and hollow-body instruments for cataract surgery in the MELAtherm. After reprocessing in the MELAtherm, the MELAstore Tray Ophthalmology, with instruments, can be sterilized, stored and transported using a MELAstore Box 200.

Up to eight MELAstore Trays Ophthalmology can be reprocessed together in the device.

Scope of delivery

| Description | Description | | |
|--|---|---|---|
| 2x Luer connection (male) MELAstore Tray Ophthalmology |  | 4x hose connector (4 mm) with external thread |  |
| 3x Luer connection (female) MELAstore Tray Ophthalmology |  | Silicone hose (10/6 mm) |  |

| Description | | Description | |
|--|---|---|---|
| 3x Luer-Lock adapter (male) |  | Silicone hose (internal) 500 mm MELAstore Tray Ophthalmology |  |
| Hose connector (6 mm) with external thread |  | Instrument holder for Flex baskets (6 pcs.) |  |
| Hose connector (6 mm) with internal thread |  | 4x Silicone bar, blue, MELAstore Tray Ophthalmology/100/50/33 |  |

The MELAstore Tray Ophthalmology consists of a lid, an upper part and a lower part including an injector rail.

For reprocessing in the MELAtherm, the upper and lower parts are loaded separately and placed in the washing chamber.

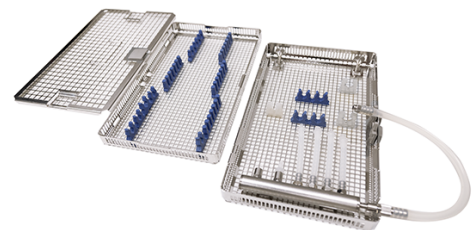

Please note the following:

- Install the hoses free of kinks and sacks.
- Keep the hoses as short as possible. Water can accumulate in long hoses.
- Make sure that hoses are not pinched off by other components or instruments.
- Do not close hoses.
- Remove hoses when not in use.
- Check the hoses, connections and instruments before and after reprocessing to ensure that they are tight. If a hose, connection or instrument has come loose, reprocess the instrument again.
- Instruments should only be reprocessed fixed in the trays. Use either instrument holders or silicone bars for this purpose.
- Only insert as many instrument holders or silicone bars into a tray as are required for one reprocessing process.

Separating the MELAstore Tray Ophthalmology

On delivery, the upper and lower part of the MELAstore Tray Ophthalmology are assembled. The upper and lower part must be separated from each other for the reprocessing in MELAtherm.

The upper part (pos. a) is hung in the lower part (pos. b).

PLEASE NOTE: The figure shows the upper and lower part without a lid.

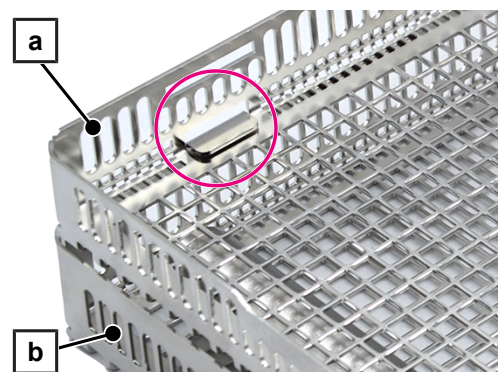

1. Push together the lock (pos. c) on the lower part and remove the upper part (pos. a) from the locking device.
2. Unhook the upper part (pos. a) from the lower part.

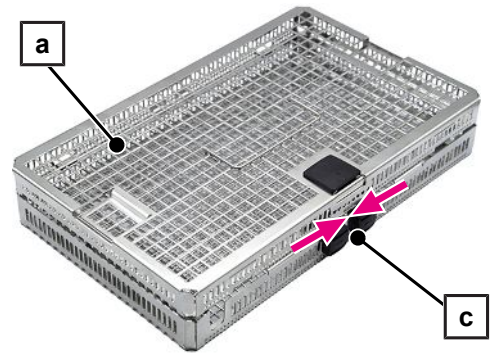

Equipping and loading the upper part

The following must be fulfilled or present:

- ✓ The top and bottom part are separated.

 1. Slide the lid lock (pos. a) in the direction of the arrow and remove the lid from the lock.
 2. Unhook the lid from the upper part (see circular marking).

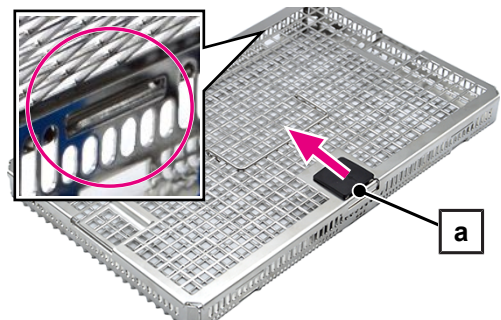

3. Insert the silicone bars and/or instrument holders. If necessary, cut off individual silicone bars and insert them separately.
4. Push the feet (pos. b) firmly into the base of the upper part so that they protrude on the underside.

PLEASE NOTE: The silicone bars/instrument holders must be flush with the base.

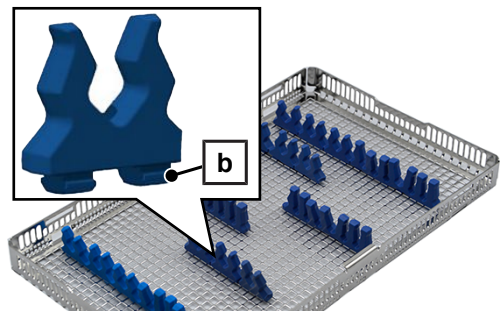

5. Load the upper part with solid instruments correctly for rinsing (e.g. hinged instruments opened, no overloading/loading on top of each other).
6. Hook the lid (pos. c) into the upper part (see circular marking) on both sides.
7. Close the upper part with the lid (pos. c). Press the lock (pos. a) of the lid onto the upper part.
 - ➡ A clicking sound can be clearly heard when it is correctly closed.

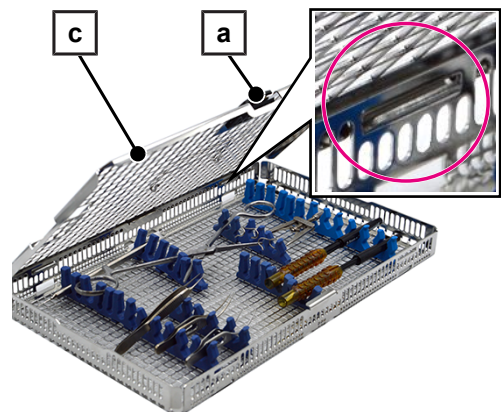

Equipping and loading the lower part

Equipping the lower part

The following must be fulfilled or present:

- ✓ The top and bottom part are separated.
 - 1. Screw the required number of Luer-Lock adapters (male, pos. c) into the injector rail.
 - 2. Screw the required number of hose connectors (4 mm, pos. b) into the injector rail.
 - 3. Cut the silicone hose from the scope of delivery (500 mm) to the required lengths.
 - 4. Push one cut silicone hose (pos. a) onto a hose connector (pos. b) on the injector rail as far as it will go.
 - 5. Equip the free end of each silicone hose with the required plastic Luer connection (pos. d).
 - 6. Insert the silicone bars and/or instrument holders. If necessary, cut off individual silicone bars and insert them separately.
 - 7. Push the feet (pos. e) firmly into the base of the lower part so that they protrude on the underside.
- PLEASE NOTE:** The silicone bars/instrument holders must be flush with the base.

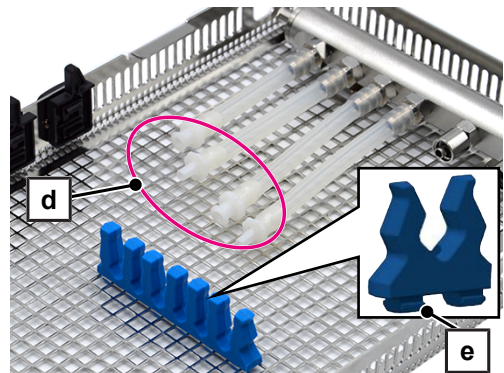
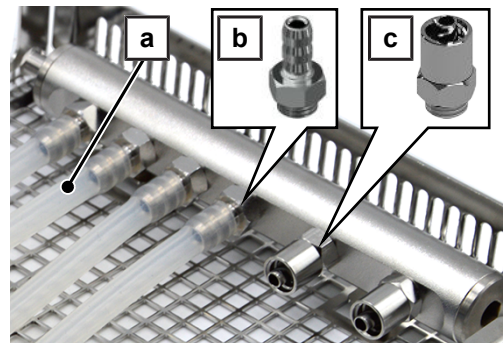

Loading the lower part

If possible, reprocess the Phaco needle of the Phaco handpiece separately.

- 1. Unscrew the Phaco needle (pos. f) from the Phaco handpiece.
- 2. Insert the Phaco needle (pos. f) into the Luer connection (female, pos. g).
- 3. Connect the Luer connection (female, pos. g) to the Luer-Lock adapter (male, pos. c) on the injector rail.

PLEASE NOTE: Due to different geometries of the Phaco needle, it may not be possible to insert it fully into the Luer connection (female). In this case, the Luer connection cannot be connected to the Luer-Lock adapter (male). Leave the Phaco needle screwed onto the Phaco handpiece for reprocessing.

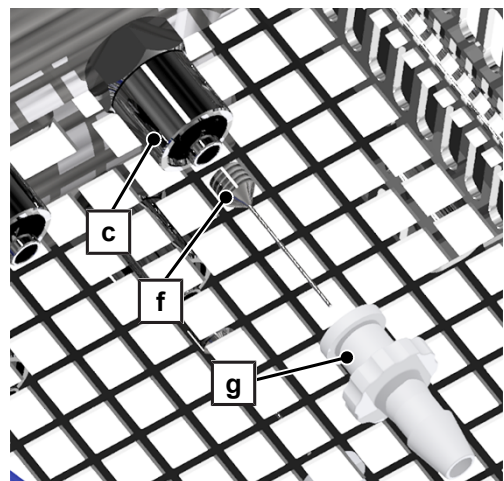

- 4. Connect the suitable hollow-body instrument to the injector rail (pos. h) by half-turning the Luer-Lock adapter (male, pos. i).
- NOTICE! Warning of material damage**
If the hollow-body instrument is screwed into the Luer-Lock adapter too tightly, increased force must be applied to undo it. Screw in the instrument hand-tight only.
- 5. Connect the appropriate hollow-body instrument with the Luer connection (pos. j) to the silicone hose.

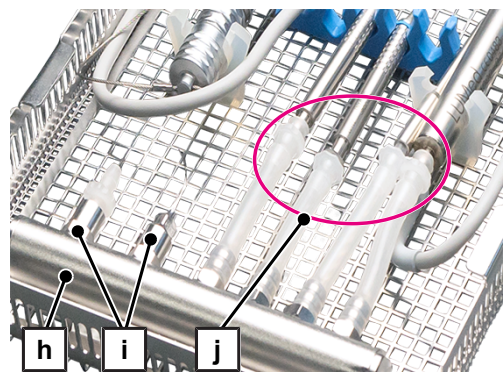

- 6. Fix the instruments in the silicone bars/instrument holders (pos. l).
- 7. Lay the cable of the Phaco handpiece in the shape of an eight around the bars (pos. k).

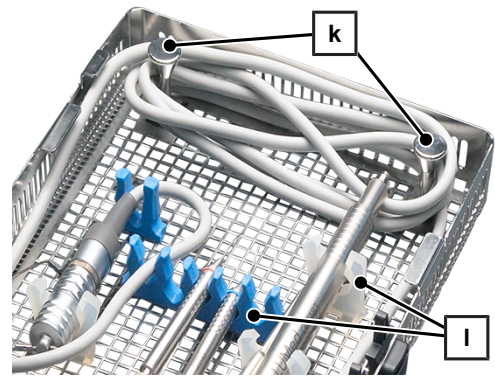

- 8. Close off the unused connections of the injector rail with a screw plug.
- 9. If available, close the Luer-Lock adapter (male) with the closure (female) for Luer/Luer-Lock.
- 10. If available, you can close the lower part with the separately available "Protective cover MELAstare Tray OTS / Lid OTS light".

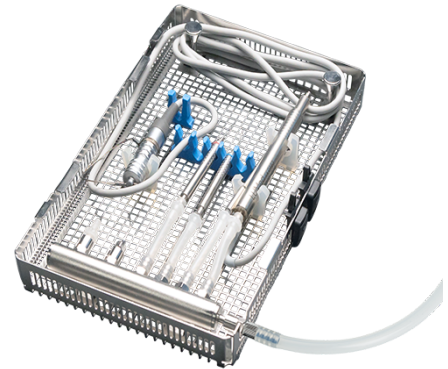

Inserting the upper and lower part into the washing chamber

The parts are loaded into the washing machine with the help of a Universal holder Flex 1 to 4. Per batch, up to eight upper parts and lower parts can be inserted for reprocessing.

⚠ WARNING

Warning of contamination

If the complete MELAstare Tray Ophthalmology (i.e. upper part and lower part connected) is placed in the washing chamber, proper reprocessing of the instruments is not ensured.

- Place the upper part and the lower part of the MELAstare Tray Ophthalmology separately in the lower basket of the MELAtherm.

The following must be fulfilled or present:

- ✓ The central filter is inserted into the pump sump.

- 1. Screw the hose connector with external thread (6 mm) hand-tight into the injector rail module of the lower basket and push the silicone hose (10/6 mm) onto the connection until it stops.

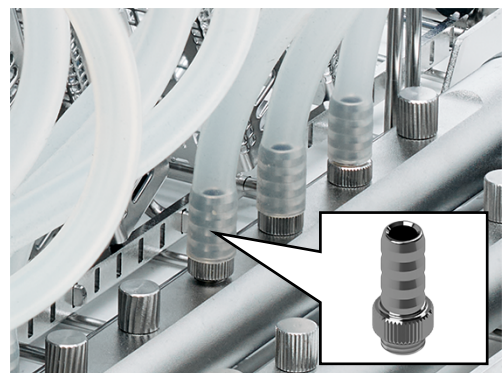

2. Screw the hose connector with internal thread (6 mm, pos. b) onto the Luer-Lock adapter (male, pos. a) by hand.

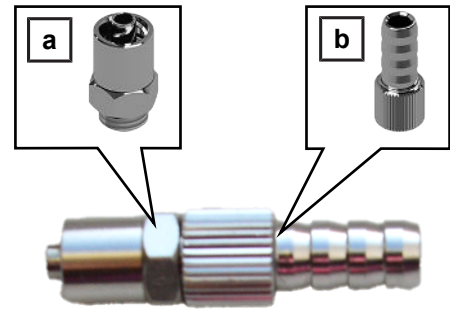

3. Slide the free end of the silicone hose (10/6 mm) onto the hose connector (pos. b) as far as it will go.

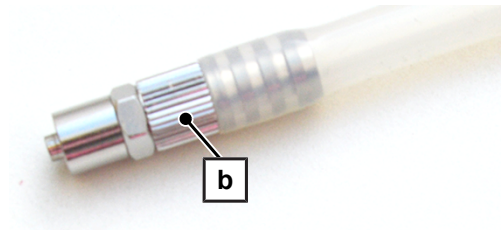

4. Place the universal holder Flex next to the injector rail module (pos. d) of the lower basket.
5. Place the lower part (pos. c) of the tray in the universal holder Flex next to the injector rail module (pos. d). For easier loading and removal, the lower part should be inclined towards the device door.

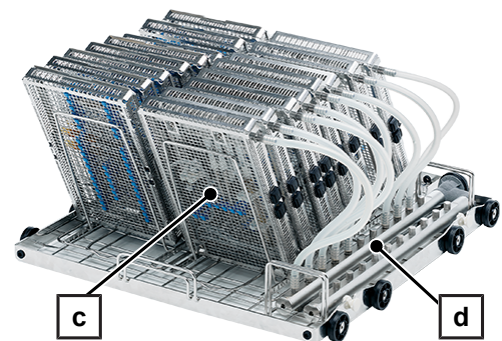

- The injector rail in the lower part is at the top.
- The connection side of the injector rail in the lower part is pointed in the direction of the injector rail module (pos. d).

6. Turn the Luer-Lock adapter (male, pos. a) by a half-turn to connect it to the injector rail (pos. e) of the lower part.

NOTICE! Warning of material damage

If the Luer-Lock adapter is screwed in too tightly, increased force must be applied to undo it. Screw in the adapter hand-tight only.

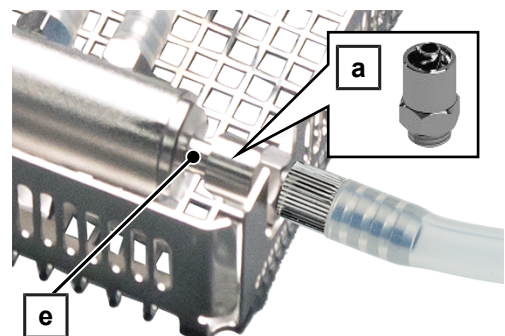

- Place the upper part (pos. f) of the tray in a universal holder Flex. For easier loading and removal, the upper part should be inclined towards the device door.

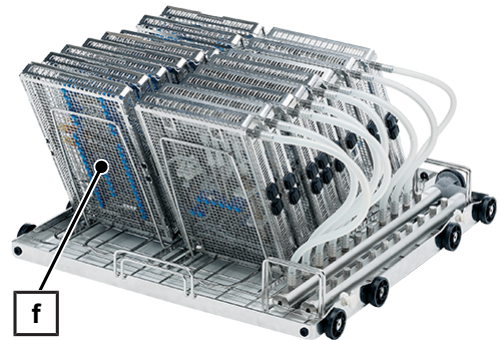

Use with MELAstore Box 200

The upper and lower part of the MELAstore Tray Ophthalmology must be assembled for use in the MELAstore Box 200.

- Remove the Luer-Lock adapter (male) including connection and silicone hose from the injector rail of the lower part with a half-turn.

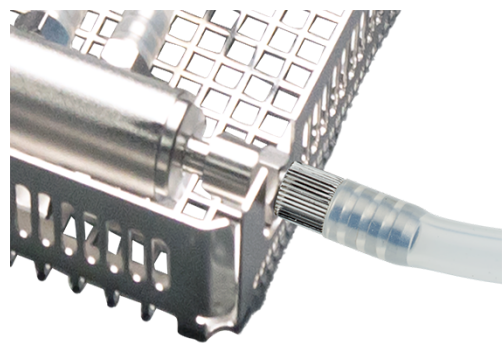

- Hook the closed upper part (pos. a) into the lower part (pos. b) on both sides.

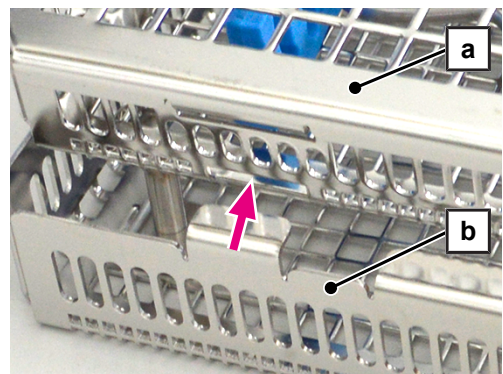

- Push down the upper part (pos. a) until it latches into the lock (pos. c) of the lower part (pos. b).

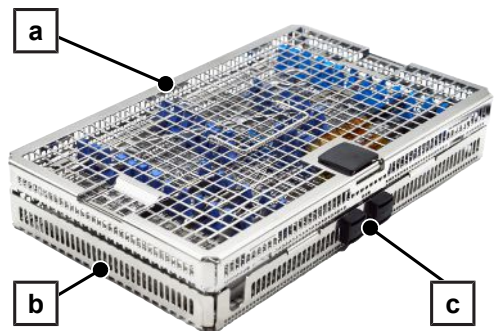

4. Insert the MELAstore Tray Ophthalmology into the MELAstore Box 200.
5. Comply with the application usage advice for the MELAstore Box 200 according to the separate document.



Used with

| Category | Article |
|---|--|
| Holders | Universal holder Flex 1-4 |
| Stackable holders and baskets (Flex system) | Instrument holder for Flex baskets |
| MELAstore Tray and silicone bars | Mount identification plate for MELAstore Tray |
| | Silicone bars for MELAstore Tray Ophthalmology/100/50/33 |
| | Protective cover MELAstore Tray OTS / Lid OTS light |
| Closure elements | Screw plug for injector rail and distributors |
| | Closure (female) for Luer/Luer-Lock |
| Hoses and hose connections | Hose connector (6 mm) with external thread |
| | Hose connector (6 mm) with internal thread |
| | Silicone hose (10/6 mm), 2 m |
| Spare parts | Lid handle MELAstore Tray Ophthalmology |
| | Luer connection (male) MELAstore Tray Ophthalmology |
| | Luer connection (female) MELAstore Tray Ophthalmology |
| | Silicone hose (internal) 500 mm MELAstore Tray Ophthalmology |
| | Closure set MELAstore Tray Ophthalmology |





See also [Components](#) [▶ page 180].







MELAstore Tray Ophthalmology light

The MELAstore Tray Ophthalmology light is used for reprocessing hollow-body instruments for cataract surgery in the MELAtherm. After reprocessing in the MELAtherm, the MELAstore Tray Ophthalmology light, with instruments, can be sterilized, stored and transported using a MELAstore Box 100.

Up to 16 MELAstore Trays Ophthalmology light can be reprocessed together in the device.

Scope of delivery

| Description | | Description | |
|--|---|---|---|
| 2x Luer connection (male) MELAstore Tray Ophthalmology |  | 4x Hose connector (4 mm) with external thread |  |
| 3x Luer connection (female) MELAstore Tray Ophthalmology |  | Silicone hose (10/6 mm) |  |

| Description | | Description | |
|--|---|---|---|
| 3x Luer-Lock adapter (male) |  | Silicone hose (internal) 500 mm MELAstore Tray Ophthalmology |  |
| Hose connector (6 mm) with external thread |  | Instrument holder for Flex baskets (6 pcs.) |  |
| Hose connector (6 mm) with internal thread |  | 2x Silicone bar, blue, MELAstore Tray Ophthalmology/100/50/33 |  |

The MELAstore Tray Ophthalmology light consists of a protective lid and a tray including an injector rail.



Please note the following:

- Install the hoses free of kinks and sacks.
- Keep the hoses as short as possible. Water can accumulate in long hoses.
- Make sure that hoses are not pinched off by other ▶components or instruments.
- Do not close hoses.
- Remove hoses when not in use.
- Check the hoses, connections and instruments before and after reprocessing to ensure that they are tight. If a hose, connection or instrument has come loose, reprocess the instrument again.
- Instruments should only be reprocessed fixed in the trays. Use either instrument holders or silicone bars for this purpose.
- Only insert as many instrument holders or silicone bars into a tray as are required for one reprocessing process.

Equipping and loading the Tray

1. Press the closure (pos. c) together and separate the lid (pos. b) from both locking positions (pos. a).
2. Unhook the protective lid.

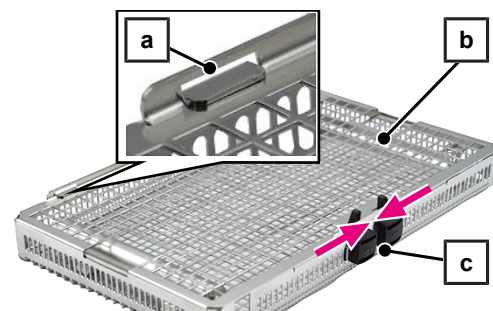

3. Screw the required number of Luer-Lock adapters (male, pos. f) into the injector rail.
4. Screw the required number of hose connectors (4 mm, pos. e) into the injector rail.
5. Cut the silicone hose from the scope of delivery (500 mm) to the required lengths.
6. Push one cut silicone hose (pos. d) onto a hose connector (pos. e) on the injector rail as far as it will go.
7. Equip the free end of each silicone hose with the required plastic Luer connection (pos. g).
8. Insert the silicone bars and/or instrument holders. If necessary, cut off individual silicone bars and insert them separately.
9. Push the feet (pos. h) firmly into the base of the lower part so that they protrude on the underside.
PLEASE NOTE: The silicone bars/instrument holders must be flush with the base.

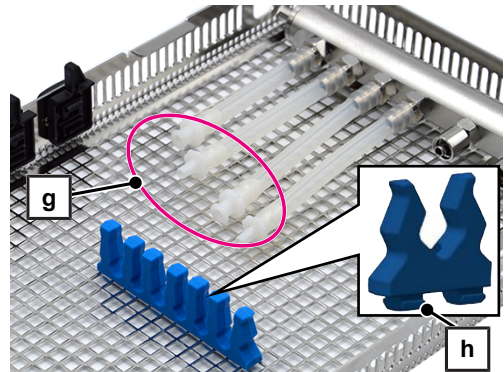
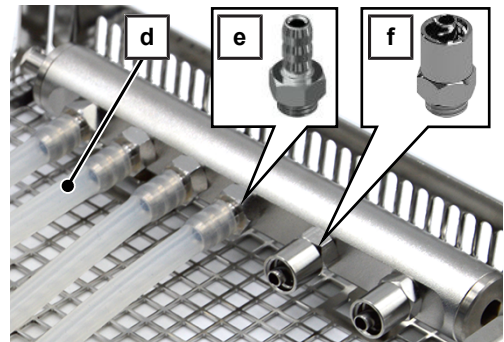

If possible, reprocess the Phaco needle of the Phaco handpiece separately.

10. Unscrew the Phaco needle (pos. i) from the Phaco handpiece.
11. Insert the Phaco needle (pos. i) into the Luer connection (female, pos. g).
12. Connect the Luer connection (female, pos. g) to the Luer-Lock adapter (male, pos. f) on the injector rail.

PLEASE NOTE: Due to different geometries of the Phaco needle, it may not be possible to insert it fully into the Luer connection (female). In this case, the Luer connection cannot be connected to the Luer-Lock adapter (male). Leave the Phaco needle screwed onto the Phaco handpiece for reprocessing.

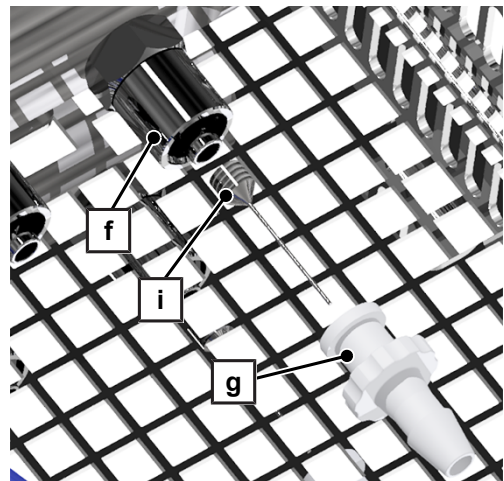

13. Connect the suitable hollow-body instrument to the injector rail (pos. j) by half-turning the Luer-Lock adapter (male, pos. f).
NOTICE! Warning of material damage
 If the hollow-body instrument is screwed into the Luer-Lock adapter too tightly, increased force must be applied to undo it. Screw in the instrument hand-tight only.
14. Connect the appropriate hollow-body instrument with the Luer connection (pos. g) to the silicone hose.

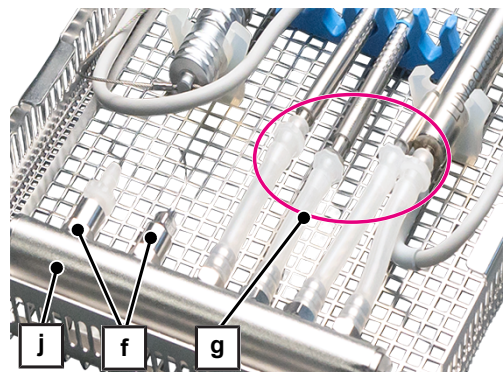

- 15. Fix the instruments in the silicone bars/instrument holders (pos. l).
- 16. Lay the cable of the Phaco handpiece in the shape of an eight around the bars (pos. k).

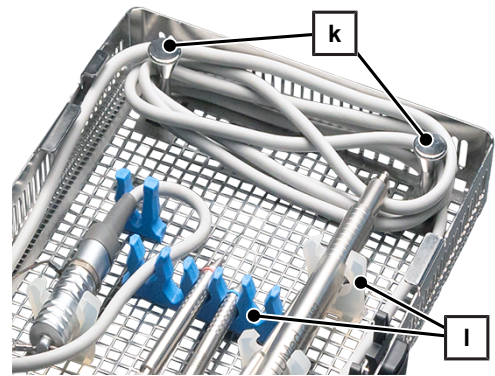

- 17. Close off the unused connections of the injector rail with a screw plug.
- 18. If available, close the Luer-Lock adapter (male) with the closure (female) for Luer/Luer-Lock.

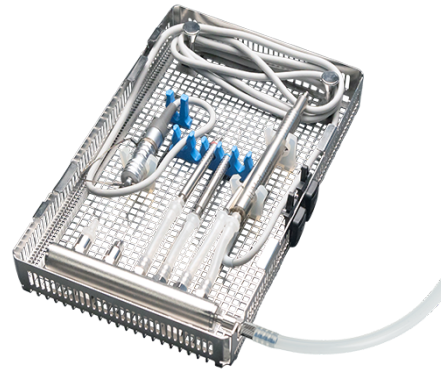

- 19. Insert the lid (pos. b) on both sides of the Tray (pos. a).
- 20. Press the lid (pos. b) down until it engages in the lock (pos. c).

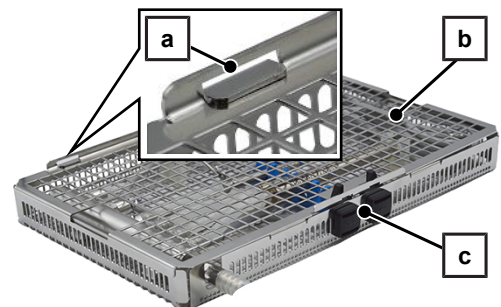

Inserting the tray into the washing chamber

The parts are loaded into the washing machine with the help of a Universal holder Flex 1 to 4. Up to 16 MELAstore Tray Ophthalmology light can be used per batch for reprocessing.

The following must be fulfilled or present:

- ✓ The central filter is inserted into the pump sump.

- 1. Screw the hose connector with external thread (6 mm) hand-tight into the injector rail module of the lower basket and push the silicone hose (10/6 mm) onto the connection until it stops.

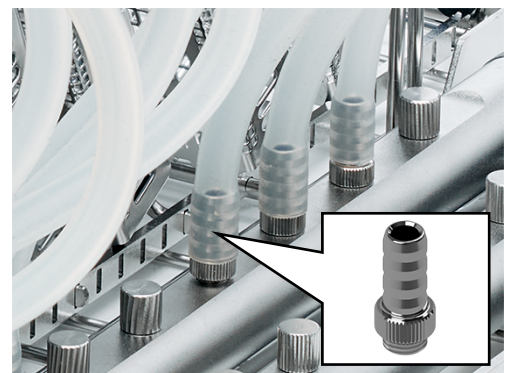

- Screw the hose connector with internal thread (6 mm, pos. b) onto the Luer-Lock adapter (male, pos. a) by hand.

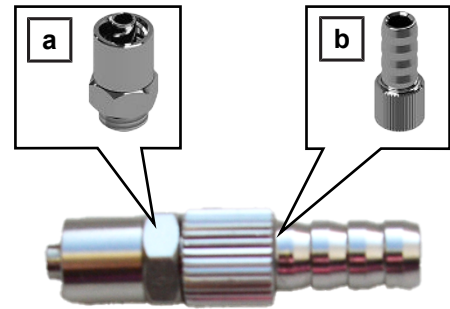

- Slide the free end of the silicone hose (10/6 mm) onto the hose connector (pos. b) as far as it will go.

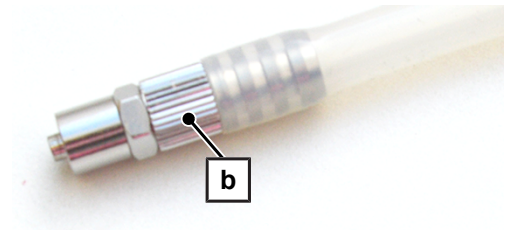

- Place the universal holder Flex on the lower basket. **PLEASE NOTE:** If you are using only one universal holder Flex, place it next to the injector rail module (pos. d) of the lower basket.

- Place the MELAstore Tray Ophthalmology light (pos. c) in the universal holder Flex. For easier loading and removal, the tray should be inclined towards the device door.

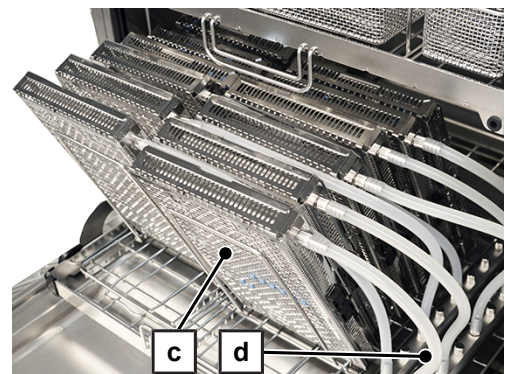

- The injector rail of the tray is at the top.
- The connection side of the injector rail of the tray is pointed in the direction of the injector rail module (pos. d).

- Turn the Luer-Lock adapter (male, pos. a) by a half-turn to connect it to the injector rail (pos. e) of the tray. **NOTICE! Warning of material damage** If the Luer-Lock adapter is screwed in too tightly, increased force must be applied to undo it. Screw in the adapter hand-tight only.

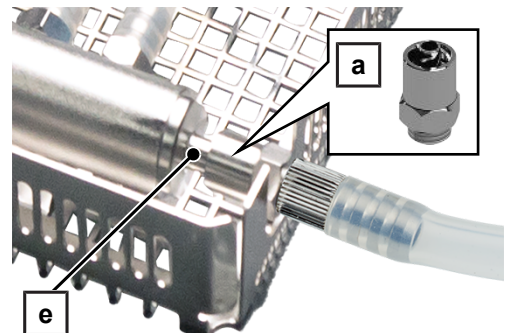

Use with MELAstore Box 100

1. Remove the Luer-Lock adapter (male) including connection and silicone hose from the injector rail of the tray with a half-turn.

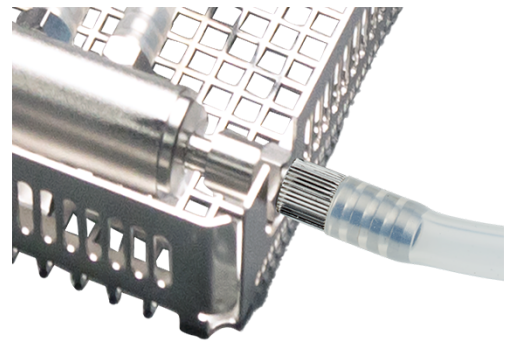

2. Insert the MELAstore Tray Ophthalmology light into the MELAstore Box 100. Comply with the application usage advice for the MELAstore Box 100 according to the separate document.



Used with

| Category | Article |
|---|--|
| Holders | Universal holder Flex 1-4 |
| Stackable holders and baskets (Flex system) | Instrument holder for Flex baskets |
| MELAstore Tray and silicone bars | Mount identification plate for MELAstore Tray |
| | Silicone bars for MELAstore Tray Ophthalmology/100/50/33 |
| | Protective cover MELAstore Tray OTS / Lid OTS light |
| Closure elements | Screw plug for injector rail and distributors |
| | Closure (female) for Luer/Luer-Lock |
| Hoses and hose connections | Hose connector (6 mm) with external thread |
| | Hose connector (6 mm) with internal thread |
| | Silicone hose (10/6 mm), 2 m |
| Spare parts | Lid handle MELAstore Tray Ophthalmology |
| | Luer connection (male) MELAstore Tray Ophthalmology |
| | Luer connection (female) MELAstore Tray Ophthalmology |
| | Silicone hose (internal) 500 mm MELAstore Tray Ophthalmology |
| | Closure set MELAstore Tray Ophthalmology |
| See also Components [▶ page 180]. | |

Silicone bars

The silicone bars are used for ordered accommodation of instruments in the MELAstore Tray and provide a secure hold during reprocessing. This also improves the drying of the instruments. Hinged instruments can be held continuously open.

Please note the following:

- Only insert as many instrument holders or silicone bars into a MELAstore Tray as are required for one reprocessing process.
 - Place as few silicone bars as possible in a single MELAstore Tray to avoid unwashed areas and to improve the drying result.
 - Note that the number and alignment of the silicone bars in the MELAstore Tray influence the reprocessing result.
1. Insert the silicone bars as required. You can cut off individual silicone bars and insert them separately.
 2. Press the feet of the silicone bars firmly into the base of the MELAstore Tray, so that they protrude from the underside.

PLEASE NOTE: The silicone bars must be flush with the base.
- ▶ Replace the silicone bars if they are visibly worn or damaged.

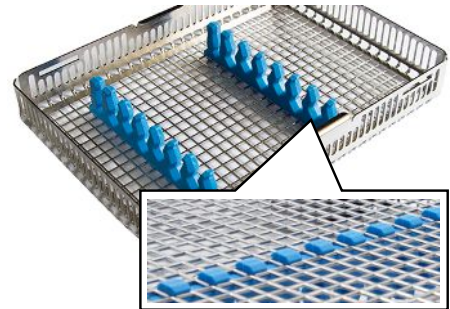

Used with

| Category | Article |
|---|------------------------------------|
| MELAstore Tray and silicone bars | MELAstore Tray 33/50/100/200 |
| | MELAstore Tray Ophthalmology |
| | MELAstore Tray Ophthalmology light |
| See also Components [▶ page 180]. | |

Injector rail module

The following view is not to scale.

Injector rail module

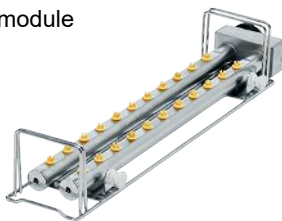

PLEASE NOTE

Use of the injector rail module and blind screws made of plastic is only permitted for the initial commissioning, maximum three weeks. After which the blind screws must be replaced with screw plugs made of stainless steel or suitable [components](#).

The injector rail module is used when hollow-body instruments are to be rinsed through. The hollow-body instruments are fixed onto the injector rail module using adapters or other connection elements.

1. Place the injector rail module on a clean, non-slip surface.
2. Screw the connections and adapters onto the injector rail module. Follow the instructions for use of the respective components.
3. Use a screw plug to seal unused connections, see [Screw plug for injector rail and distributors](#) [▶ page 112].
4. Place instruments on the adapters.
5. Use suitable silicone closure caps to close off each of the unused adapters, see [Silicone closure caps](#) [▶ page 111].
6. Pull the lower basket onto the open door.
7. Insert the injector rail module in the lower basket. Make sure that the side latching lugs (pos. a) on the injector rail module latch into the lower basket and the connection fitting faces the rear wall of the washing chamber.

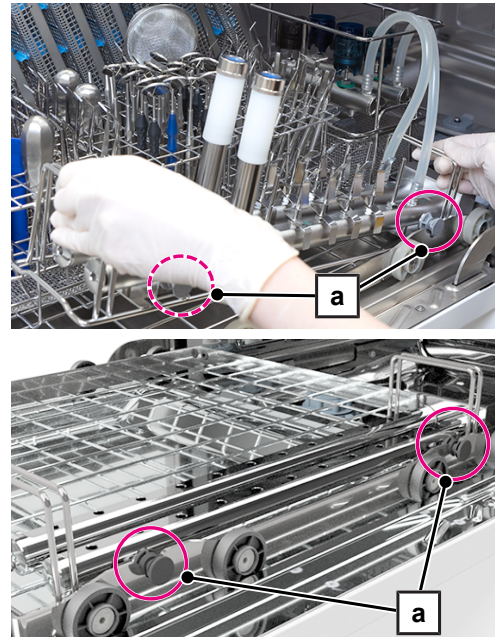

Used with

| Category | Article |
|---|--------------|
| Basis baskets | Lower basket |
| See also Components [▶ page 180]. | |

Connectors and adapters for instruments

The following views are not to scale.

Injector nozzle



Clamp spring for injector nozzle



Rinse sleeve incl. 5 inserts



Luer adapter (male)

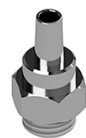

Luer-Lock adapter (male)



Luer/Luer-Lock adapter (female)



Adapters for tips and ultrasonic handpieces

Adapter M3.0 x 0.5 mm, external thread



Adapter M3.6 x PH1.5 P0.5, internal thread



Adapter M3.0 x 0.35 mm, external thread



Adapter M3.0 x 0.35 mm, internal thread



Adapter M3.5 x 0.35 mm, internal thread



Adapter M3.0 x 0.6 mm, external thread



Adapter M3.0 x 0.6 mm, internal thread



Adapter M3.5 x 0.6 mm, internal thread



Adapter M3.5 x 0.6 mm, external thread



Adapter M3.0 x 0.5 mm, internal thread



Adapter for KaVo eScaler



Marking discs for adapters

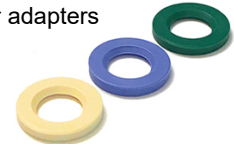

PLEASE NOTE

Sufficiently high rinse pressure is important for the cleaning. If adapters for reprocessing are not fitted with an instrument, then close them off with a suitable silicone closure cap, see [Silicone closure caps](#) [▶ page 111].

PLEASE NOTE

Check the hoses, connections and instruments before and after reprocessing to ensure that they are tight. Should a hose, connection or an instrument work loose, the instruments must be reprocessed again.

Injector nozzle

The injector nozzle is used for the reprocessing of hollow-body instruments (e.g. dental surgical aspirators, etc.).

1. If using the triple distributor including ceramic filter disc, remove the filter disc from the triple distributor.
2. Screw the injector nozzle (pos. a) onto a connection of the injector rail module (pos. c) or the triple distributor (pos. b).
3. Tighten the injector nozzle by hand with a suitable open-end spanner.
4. Fit the hollow-body instruments on the injector nozzle and fix them with a clamp spring if necessary.
5. Close off the injector nozzle with a suitable silicone closure cap if it is not fitted with an instrument, see [Silicone closure caps](#) [▶ page 111].

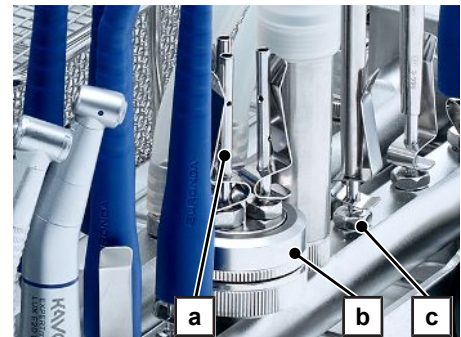

Used with

| Category | Article |
|---|--|
| Injector rail | Injector rail module |
| Connectors and adapters for instruments | Clamp spring for injector nozzle |
| Distributor | Triple distributor |
| | Triple distributor incl. ceramic filter disc |
| Closure elements | Silicone closure cap, green |
| See also Components [▶ page 180]. | |

Clamp spring for injector nozzle

The clamp spring is used to fix light hollow-body instruments on the injector nozzle so that they do not slip off the injector nozzle due to the rinse pressure.

PLEASE NOTE: MELAG recommends that you do not use the clamp springs if the injector nozzle is used together with the triple distributor including ceramic filter disc.

- ▶ Gently compress the clamp spring and slide it over the injector nozzle.

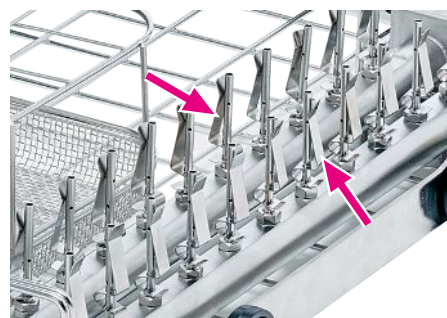

Used with

| Category | Article |
|---|-----------------|
| Connectors and adapters for instruments | Injector nozzle |
| See also Components [▶ page 180]. | |

Rinse sleeve incl. 5 inserts

The rinse sleeve is used as an adapter for the reprocessing of hollow-body instruments with an external diameter of 2-11 mm and a non-standardised shoulder. The respective suitable silicone insert is selected for this.

1. Insert the suitable silicone insert into the rinse sleeve (pos. a).
2. Screw the rinse sleeve onto a connection of the injector rail module or connect the rinse sleeve to the injector rail module via a silicone hose.
3. If necessary, lay the rinse sleeve including hose in a Flex basket.
4. Insert the instrument into the rinse sleeve with the shank side first.

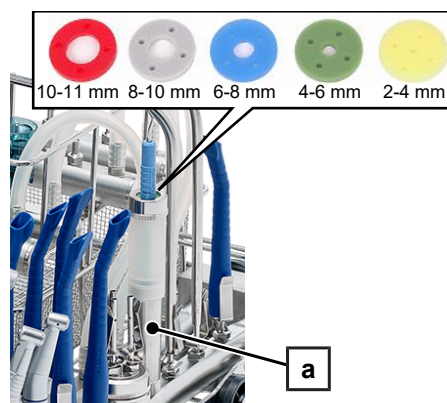

Rinse sleeve with rinse sleeve extension

The rinse sleeve comes with a rinse sleeve extension. This is used for reprocessing long hollow-body instruments without a defined connection option (e.g. rigid endoscopes and magnetostrictive attachments).

Routine check

- ▶ Check the rinse sleeve extension regularly for soiling and clean if necessary.

▲ WARNING

Warning of contamination from insufficient disinfection

Fine filtering of the rinse liquor is required if hollow-body instruments with an internal diameter ≤ 0.8 mm are to be reprocessed.

- Only insert the rinse sleeve together with the filter disc housing or the central filter.

1. Screw the rinse sleeve extension (pos. b) between the rinse sleeve (pos. c) and the shank (pos. a) of the rinse sleeve.
2. Insert the instrument into the receptacle of the rinse sleeve extension.

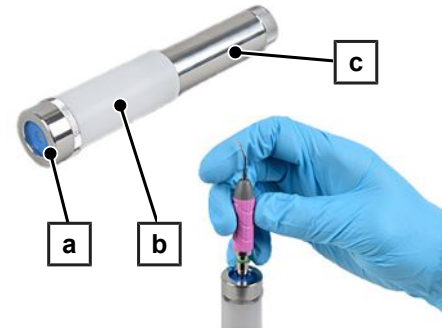

The “water inlet” opening of the instrument must be inside the rinse sleeve extension.

The “water outlet” opening of the instrument must be outside the rinse sleeve extension.

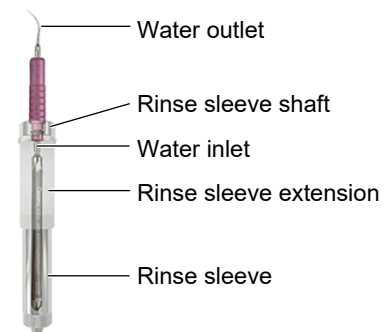

Used with

| Category | Article |
|---------------------------------------|--|
| Injector rail | Injector rail module |
| Adapters for transmission instruments | Filter disc housing incl. ceramic filter disc |
| Hoses and hose connections | Silicone hose (10/6 mm) with connectors, 0.5 m |
| Spare parts | Silicone insert for rinse sleeve, red/grey/blue/gre/yellow |

See also [Components](#) [▶ page 180].

Adapters for Luer and Luer-Lock

The adapter (male) for Luer is used for the reprocessing instruments/cannulas with Luer connection (female).

The adapter (female) for Luer/Luer-Lock is used for the reprocessing of instruments/cannulas with Luer or Luer-Lock connection (male).

1. Screw the adapter onto a connection of the injector rail module, the filter disc housing or the triple distributor.
2. Tighten the adapter by hand with a suitable open-end spanner.
3. Plug the instrument firmly onto the adapter while rotating.
4. Since the instruments are only plugged onto the adapters and not screwed, check that the instruments are firmly seated before and after reprocessing.



Used with

| Category | Article | |
|---|---|-------------------------------------|
| Injector rail | Injector rail module | -- |
| Adapters for transmission instruments | Filter disc housing incl. ceramic filter disc | -- |
| Distributor | Triple distributor | -- |
| | Triple distributor incl. ceramic filter disc | -- |
| Closure elements | Closure (female) for Luer/Luer-Lock | for Luer adapter (male) |
| | Closure (male) for Luer-Lock | for Luer/Luer-Lock adapter (female) |
| See also Components [▶ page 180]. | | |

Adapter (male) for Luer-Lock

The adapter (male) for Luer-Lock is used for the reprocessing of instruments/cannulas with Luer-Lock connection (female).

1. Screw the adapter onto a connection of the injector rail module, the filter disc housing or the triple distributor.
2. Tighten the adapter by hand with a suitable open-end spanner.
3. Screw the instrument hand-tight onto the adapter.













Used with

| Category | Article | |
|---|---|--|
| Injector rail | Injector rail module | |
| Adapters for transmission instruments | Filter disc housing incl. ceramic filter disc | |
| Distributor | Triple distributor | |
| | Triple distributor incl. ceramic filter disc | |
| Closure elements | Closure (female) for Luer/Luer-Lock | |
| See also Components [▶ page 180]. | | |

Adapters for tips and ultrasonic handpieces

The adapters are used to clean the interiors of ultrasonic and scaler tips and handpieces.

Compatibility

| Adapters | | Compatible with |
|------------------------------------|---|---|
| M3.0 x 0.5 mm, external thread |  | KaVo SONOsoft, PiezoLUX EMS Piezon/Piezon LED W&H Piezo Scaler: Tigon, Tigon+, Pyon 2 Surgery: Piezomed Komet PiezoLine EM1, PiezoLine KA1, PiezoLine KA2 Mectron Multipiezo, PiezoSmart, Micropiezo, Compact Piezo Hu-Friedy Piezo E-Series (EMS) Woodpecker Prophy+ without A/S indication |
| M3.6 x PH1.5 P0.5, internal thread |  | KaVo SONICflex quick 2008 |
| M3.0 x 0.35 mm, external thread |  | KaVo PiezoLED, PIEZOsoft |
| M3.0 x 0.35 mm, internal thread |  | KaVo PiezoLED, PIEZOsoft |
| M3.5 x 0.35 mm, internal thread |  | Planmeca LM ProPower |
| M3.0 x 0.6 mm, external thread |  | Acteon (Satelec) Newtron, Suprasson NSK Varios NSK, Satelec Hu-Friedy Piezo S-Series (NSK, Satelec, Hu-Friedy) Ultradent Newtron Woodpecker Prophy+ with A/S indication, Prophy+ "gold" DTE D600, Prophy+ |
| M3.0 x 0.6 mm, internal thread |  | Acteon (Satelec) Newtron, Suprasson NSK Varios NSK, Satelec Woodpecker Prophy+ with A/S indication, Prophy+ "gold" DTE D600, Prophy+ |
| M3.5 x 0.6 mm, internal thread |  | Sirona SIROSON, SIROSONIC, PerioSonic Komet PiezoLineS11 Dürr Vector Scaler |
| M3.5 x 0.6 mm, external thread |  | Sirona SIROSON, SIROSONIC, PerioSonic |
| M3.0 x 0.5 mm, internal thread |  | KaVo SONICflex 2000, 2003 EMS Piezon/Piezon LED Sirona SIROAIR L W&H air scaler: Proxeo, Synea, Alegria Komet SonicLine: Komet SF1LM NSK air scaler: Ti-Max S970, AS2000 Woodpecker Prophy+ without A/S indication |
| Adapter for KaVo eScaler |  | KaVo eScaler handpiece |

▲ WARNING

Warning of contamination

Using tips with an external coolant connection reduces the cleaning performance.

- Connect additional adapters for external spray channels, see [Adapter for external spray channels](#) [▶ page 105].
- Comply with the specifications from the instrument manufacturer.

Please note the following:

- Reprocessing with a torque spanner connected is possible, as far as this has been approved by the manufacturer for automatic reprocessing.
- Ensure that you use an adapter with a compatible thread to prevent damage to the instrument.
- Comply with the instrument manufacturer's instructions regarding reprocessing in a washer-disinfector.

1. **With central filter:** Screw the adapter onto a connection of the injector basket Flex 1 or directly onto the injector rail module.
2. **Without central filter:** Screw the adapter onto the connection of the filter disc housing.
3. Tighten the adapter by hand with a suitable open-end spanner.
4. Use the torque spanner from the instrument manufacturer to screw the tips on and off.



Used with

| Category | Article |
|---|---|
| Injector rail | Injector rail module |
| Adapters for transmission instruments | Filter disc housing incl. ceramic filter disc |
| Distributor | Injector basket Flex 1 |
| Closure elements | Silicone closure cap, green |
| See also Components [▶ page 180]. | |

Marking discs for adapters

The marking discs are used to visually distinguish the adapters for tips and ultrasonic handpieces. This prevents instruments from being accidentally screwed onto the wrong adapters and possibly damaging the thread.

1. Unscrew the adapter from the injector rail module or injector basket Flex 1.
2. Slide the marking disc over the large thread of the adapter.
3. Screw the adapter together with the marking disc back onto the injector rail module or the injector basket Flex 1.



Used with

| Category | Article |
|---|---|
| Connectors and adapters for instruments | Adapters for tips and ultrasonic handpieces |
| See also Components [▶ page 180]. | |

Adapters for transmission instruments

The following views are not to scale.

Adapter for ISO connector (INTRA)



Adapter for turbines NSK connector



Adapter for Sirona T1 Classic



Adapter for KaVo/BienAir contra angle heads



Adapter for turbines W&H connector (Roto Quick)



Adapter for turbines Sirona connector



Adapter for turbines KaVo connector (MULTIflex)



Adapter for EMS AIR-FLOW Handy 3.0



Adapter for EMS AIR-FLOW Prophylaxis Master



Adapter for NSK Prophy Mate Neo (airflow)



Adapter for NSK Varios Combi Pro (airflow)



Adapter for MyLunos powder water jet nozzle



Adapter for Sirona Sprayvit nozzle



Adapter for KaVo multifunctional cannula



Filter disc housing incl. ceramic filter disc



Distance sleeve



Adapter for external spray channels

















Universal adapter incl. 3 inserts and ceramic filter disc



Instrument holder for universal adapter



Selection aid for the use of adapters for transmission instruments

| Transmission instruments | | Adapters for transmission instruments | |
|------------------------------------|---|--|---|
| Handpieces Contra-angles | Intracoupling | Adapter for ISO connector (INTRA) |  |
| | AIR-FLOW | Adapter for EMS AIR-FLOW Handy 3.0 |  |
| | | Adapter for EMS AIR-FLOW Prophylaxis Master |  |
| | | Adapter for NSK Prophy Mate Neo (airflow) |  |
| | | Adapter for NSK Varios Combi Pro (airflow) |  |
| | | Adapter for MyLunos powder water jet nozzle |  |
| | Sirona T1 Classic | Adapter for Sirona T1 Classic |  |
| Heads of the KaVo contra angles | Adapter for KaVo/BienAir contra angle heads |  | |
| Turbines | NSK Phatelus | Adapter for turbines NSK connector |  |
| | W&H ROTO QUICK | Adapter for turbines W&H connector (Roto Quick) |  |
| | Sirona quick coupling R/F | Adapter for turbines Sirona connector |  |
| | KaVo Multiflex LUX | Adapter for turbines KaVo connector (MULTIflex) |  |
| Multifunction syringes | Multifunction cannula | Adapter for KaVo multifunctional cannula |  |
| | | Adapter for Sirona Sprayvit nozzle |  |
| Hollow-body instruments in general | without a specific connection | Universal adapter incl. 3 inserts and ceramic filter disc |  |
| | <ul style="list-style-type: none"> • For example, for reprocessing transmission instruments, attachments of powder jet devices, etc. • Connection possible with and without filter disc. • Inserts: green (Ø 16 mm), blue (Ø 20 mm), white (Ø 22 mm) • For other multifunction syringes, the universal adapter can be used. | | |

NOTICE

Warning of material damage from incorrect use

Transmission instruments can be damaged if filters are not used.

- Reprocess the transmission instruments only when suitable filters are installed.

PLEASE NOTE

Sufficiently high rinse pressure is important for the cleaning. If adapters for reprocessing are not fitted with an instrument, then close them off with a suitable silicone closure cap, see [Silicone closure caps](#) [▶ page 111].

Adapter for ISO connector (INTRA)

The adapter is used to hold mechanically driven transmission instruments (e.g. handpieces, contra angles). Contra angles with a short ISO connection (e.g. Sirona T1/T2-Line, W&H Synea Vision Short Edition, NSK nlx nano etc.) can also be connected.

1. **With central filter:** Screw the adapter onto a connection of the injector rail module or injector basket Flex 1.
2. **Without central filter:** Screw the adapter onto a filter disc housing.
3. Tighten the adapter hand-tight with the open-end spanner (size 10).
4. Plug the instrument onto the adapter until it snaps into place.



Used with

| Category | Article |
|---|---|
| Injector rail | Injector rail module |
| Adapters for transmission instruments | Filter disc housing incl. ceramic filter disc |
| Distributor | Injector basket Flex 1 |
| Closure elements | Silicone closure cap, white |
| See also Components [▶ page 180]. | |

Adapter for turbines NSK connector (Phatelus)

The adapter is used to hold turbines with NSK Phatelus connection.

1. **With central filter:** Screw the adapter onto a connection of the injector rail module or injector basket Flex 1.
2. **Without central filter:** Screw the adapter onto a filter disc housing.
3. Tighten the adapter by hand.
4. Plug the instrument onto the adapter until it snaps into place.



Used with

| Category | Article |
|---|---|
| Injector rail | Injector rail module |
| Adapters for transmission instruments | Filter disc housing incl. ceramic filter disc |
| Distributor | Injector basket Flex 1 |
| Closure elements | Silicone closure cap, white |
| See also Components [▶ page 180]. | |

Adapter for Sirona T1 Classic

The adapter is used to hold handpieces and contra angles of the Sirona Classic series.

1. **With central filter:** Screw the adapter onto a connection of the injector rail module or injector basket Flex 1.
2. **Without central filter:** Screw the adapter onto a filter disc housing.
3. Tighten the adapter hand-tight with the open-end spanner (size 10).
4. Plug the instrument onto the adapter until it snaps into place.

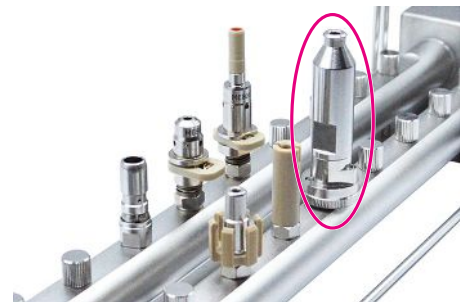

Used with

| Category | Article |
|---|---|
| Injector rail | Injector rail module |
| Adapters for transmission instruments | Filter disc housing incl. ceramic filter disc |
| Distributor | Injector basket Flex 1 |
| Closure elements | Silicone closure cap, blue |
| See also Components [▶ page 180]. | |

Adapter for contra angle heads KaVo/BienAir

The adapter is used to hold the removable heads of KaVo and Bien-Air contra angles.

1. **With central filter:** Screw the adapter onto a connection of the injector rail module or injector basket Flex 1.
2. **Without central filter:** Screw the adapter onto a filter disc housing.
3. Tighten the adapter hand-tight with the open-end spanner (size 10).
4. Plug the instrument onto the adapter until it snaps into place.



Used with

| Category | Article |
|---|---|
| Injector rail | Injector rail module |
| Adapters for transmission instruments | Filter disc housing incl. ceramic filter disc |
| Distributor | Triple distributor incl. ceramic filter disc |
| | Injector basket Flex 1 |
| Closure elements | Silicone closure cap, white |
| See also Components [▶ page 180]. | |

Adapter for turbines with W&H connector (Roto Quick)

The adapter is used to hold W&H turbines.

1. **With central filter:** Screw the adapter onto a connection of the injector rail module or injector basket Flex 1.
2. **Without central filter:** Screw the adapter onto a filter disc housing.
3. Tighten the adapter hand-tight with the open-end spanner (size 10).
4. Plug the instrument onto the adapter until it snaps into place.

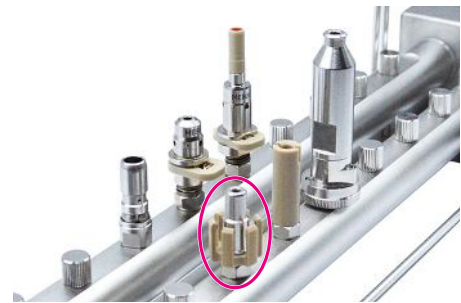

Used with

| Category | Article |
|---|---|
| Injector rail | Injector rail module |
| Adapters for transmission instruments | Filter disc housing incl. ceramic filter disc |
| Distributor | Injector basket Flex 1 |
| Closure elements | Silicone closure cap, blue |
| See also Components [▶ page 180]. | |

Adapter for turbines with Sirona connector

The adapter is suitable for all turbines with Sirona quick-release coupling R/F.

1. **With central filter:** Screw the adapter onto a connection of the injector rail module or injector basket Flex 1.
2. **Without central filter:** Screw the adapter onto a filter disc housing.
3. Tighten the adapter hand-tight with the open-end spanner (size 10).
4. Plug the instrument onto the adapter until it snaps into place.

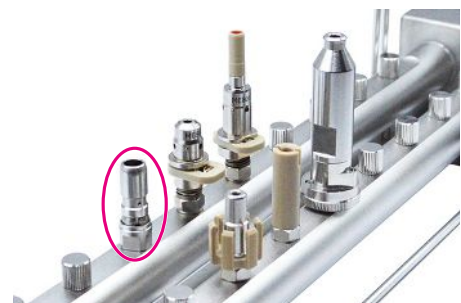

Used with

| Category | Article |
|---|---|
| Injector rail | Injector rail module |
| Adapters for transmission instruments | Filter disc housing incl. ceramic filter disc |
| Distributor | Injector basket Flex 1 |
| Closure elements | Silicone closure cap, blue |
| See also Components [▶ page 180]. | |

Adapter for turbines with KaVo connector (MULTiflex)

The adapter is used to hold instruments with MULTiflex connection.

1. **With central filter:** Screw the adapter onto a connection of the injector rail module or injector basket Flex 1.
2. **Without central filter:** Screw the adapter onto a filter disc housing.
3. Tighten the adapter hand-tight with the open-end spanner (size 10).
4. Plug the instrument onto the adapter until it snaps into place.

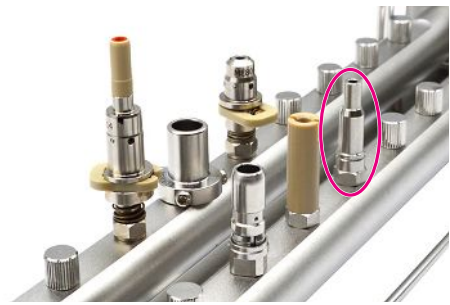

Used with

| Category | Article |
|---|---|
| Injector rail | Injector rail module |
| Adapters for transmission instruments | Filter disc housing incl. ceramic filter disc |
| Distributor | Injector basket Flex 1 |
| Closure elements | Silicone closure cap, blue |
| See also Components [▶ page 180]. | |

Adapter for EMS AIR-FLOW Handy 3.0

The adapter is used to hold and clean handpieces for air polishers.

1. **With central filter:** Screw the adapter onto a connection of the injector rail module or injector basket Flex 1.
2. **Without central filter:** Screw the adapter onto a filter disc housing.
3. Tighten the adapter hand-tight with the open-end spanner (size 10).
4. Plug the instrument onto the adapter until it audibly and visibly snaps into place.
5. **After reprocessing:** Operate the latch fastener and pull the instrument forcefully straight upwards off the adapter.

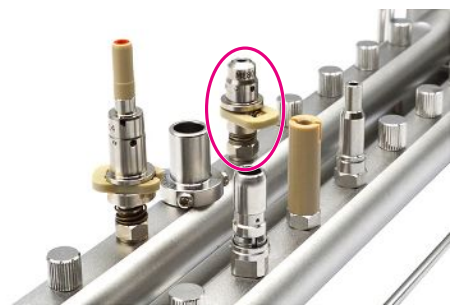

Used with

| Category | Article |
|---|---|
| Injector rail | Injector rail module |
| Adapters for transmission instruments | Filter disc housing incl. ceramic filter disc |
| Distributor | Injector basket Flex 1 |
| Closure elements | Silicone closure cap, white |
| Spare parts | Clip and spring for EMS AIR-FLOW adapter |
| See also Components [▶ page 180]. | |

Adapter for EMS AIR-FLOW Prophylaxis Master

The adapter is used to hold and clean handpieces for air polishers.

1. **With central filter:** Screw the adapter onto a connection of the injector rail module or injector basket Flex 1.
2. **Without central filter:** Screw the adapter onto a filter disc housing.
3. Tighten the adapter hand-tight with the open-end spanner (size 10).
4. Plug the instrument onto the adapter until it audibly and visibly snaps into place.
5. **After reprocessing:** Operate the latch fastener and pull the instrument forcefully straight upwards off the adapter.



Used with

| Category | Article |
|---|--|
| Injector rail | Injector rail module |
| Adapters for transmission instruments | Filter disc housing incl. ceramic filter disc |
| Distributor | Injector basket Flex 1 |
| Closure elements | Silicone closure cap, white |
| Spare parts | Holding sleeve for EMS AIR-FLOW Prophylaxis Master |
| | Seal for EMS AIR-FLOW Prophylaxis Master |
| | Clip and spring for EMS AIR-FLOW adapter |
| See also Components [▶ page 180]. | |

Adapter for NSK Prophy Mate Neo (airflow)

The adapter is used to hold and clean handpieces for air polishers.

1. **With central filter:** Screw the adapter onto a connection of the injector rail module or injector basket Flex 1.
2. **Without central filter:** Screw the adapter onto a filter disc housing.
3. Tighten the adapter hand-tight with the open-end spanner (size 10).
4. Plug the instrument onto the adapter until it snaps into place.



Used with

| Category | Article |
|---|---|
| Injector rail | Injector rail module |
| Adapters for transmission instruments | Filter disc housing incl. ceramic filter disc |
| Distributor | Injector basket Flex 1 |
| See also Components [▶ page 180]. | |

Adapter for NSK Varios Combi Pro (airflow)

The adapter is used to hold and clean handpieces for air polishers.

1. **With central filter:** Screw the adapter onto a connection of the injector rail module or injector basket Flex 1.
2. **Without central filter:** Screw the adapter onto a filter disc housing.
3. Tighten the adapter hand-tight with the open-end spanner (size 10).
4. Plug the instrument onto the adapter until it snaps into place.



Used with

| Category | Article |
|---|---|
| Injector rail | Injector rail module |
| Adapters for transmission instruments | Filter disc housing incl. ceramic filter disc |
| Distributor | Injector basket Flex 1 |
| Closure elements | Silicone closure cap, white |
| See also Components [▶ page 180]. | |

Adapter for MyLunos powder water jet nozzle

The adapter is used to hold and clean handpieces for air polishers.

1. **With central filter:** Screw the adapter onto a connection of the injector rail module or injector basket Flex 1.
2. **Without central filter:** Screw the adapter onto a filter disc housing.
3. Tighten the adapter hand-tight with the open-end spanner (size 10).
4. Plug the instrument onto the adapter until it audibly and visibly snaps into place.
5. **After reprocessing:** Operate the latch fastener and pull the instrument forcefully straight upwards off the adapter.



Used with

| Category | Article |
|---|---|
| Injector rail | Injector rail module |
| Adapters for transmission instruments | Filter disc housing incl. ceramic filter disc |
| Distributor | Injector basket Flex 1 |
| Closure elements | Silicone closure cap, white |
| See also Components [▶ page 180]. | |

Adapter for Sirona Sprayvit nozzle

The adapter is used for internal cleaning of multifunction cannulas.

1. **With central filter:** Screw the adapter onto a connection of the injector rail module or injector basket Flex 1.
2. **Without central filter:** Screw the adapter onto a filter disc housing.
3. Tighten the adapter hand-tight with the open-end spanner (size 10).
4. Plug the instrument onto the adapter until it snaps into place.



Used with

| Category | Article |
|---|---|
| Injector rail | Injector rail module |
| Adapters for transmission instruments | Filter disc housing incl. ceramic filter disc |
| Distributor | Injector basket Flex 1 |
| Closure elements | Silicone closure cap, white |
| See also Components [▶ page 180]. | |

Adapter for KaVo multifunctional cannula

The adapter is for internal cleaning of multifunctional cannulas (e.g. KaVo 3-function cannula, KaVo multifunctional cannula).

1. **With central filter:** Screw the adapter onto a connection of the injector rail module or injector basket Flex 1.
2. **Without central filter:** Screw the adapter onto a filter disc housing.
3. Tighten the adapter hand-tight with the open-end spanner (size 10).
4. Plug the instrument onto the adapter until it snaps into place.



Used with

| Category | Article |
|---|---|
| Injector rail | Injector rail module |
| Adapters for transmission instruments | Filter disc housing incl. ceramic filter disc |
| Distributor | Injector basket Flex 1 |
| Closure elements | Silicone closure cap, white |
| See also Components [▶ page 180]. | |

Filter disc housing incl. ceramic filter disc

The filter disc housing is used to filter a single connection on the injector rail module if a central filter is not inserted in the pump sump of the device. Both the reusable metal filter disc and the ceramic filter disc can be used.

⚠ WARNING

Warning of contamination

The filter effect can be impaired and the cleaning performance is reduced if the filter housing is not closed off correctly or the connection on the injector rail module is not correct.

- Always check whether the filter housing is tightly closed and correctly connected on the injector rail module.

Please note the following:

- The reprocessing of hollow-body instruments with an inside diameter of ≤ 0.8 mm requires a fine filter of the liquor.
- Do not combine the filter disc housing with other filter elements. Only connect the filter disc housing on the injector rail module.

All available adapters can be screwed onto the filter disc housing. If using the injector basket Flex 1 and the injector rail module, two filter disc housings are needed to connect both connection hoses.

1. Screw the filter disc housing onto a connection of the injector rail module.
2. Tighten the filter disc housing by hand.



Inserting/replacing the ceramic/metal filter disc

The filter disc must be replaced at regular intervals, see [Filter inserts](#) [▶ page 109].

1. Rinse the reusable metal filter disc (pos. d) under running water before first use.
Rinse the new ceramic filter disc (pos. c) briefly under running water.
2. Remove any dirt particles from the adapter, preferably with compressed air.
3. Place the filter disc in the yellow silicone insert (pos. b).
4. Insert the yellow silicone insert (pos. b) with the filter disc (pos. c/d) facing downwards into the lower part (pos. e) of the filter disc housing.
PLEASE NOTE: Always insert the silicone insert (pos. b) with the reusable metal filter disc (pos. d) into the filter disc housing (pos. e) with the printed side facing downwards.
5. Place the upper section (pos. a) of the filter disc housing on the lower section (pos. e) and turn the bayonet cap to its fullest extent (the markings lie over each other).

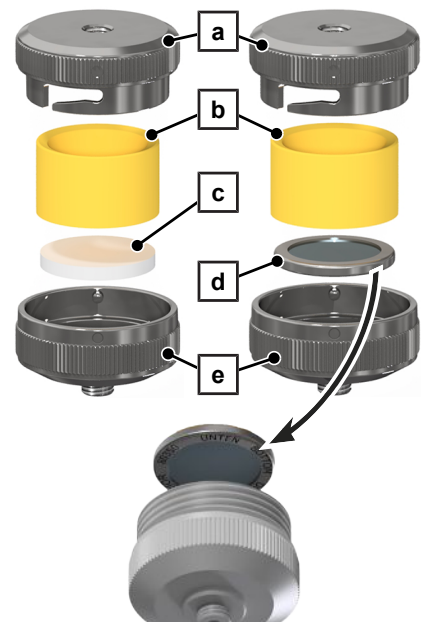

Used with

| Category | Article |
|---|------------------------------|
| Injector rail | Injector rail module |
| Filter inserts | Ceramic filter disc |
| | Metal filter disc |
| Connectors and adapters for instruments | all adapters |
| | Rinse sleeve incl. 5 inserts |

| Category | Article |
|---|--|
| Adapters for transmission instruments | all adapters |
| Hoses and hose connections | Hose connector (6 mm) with external thread |
| | Silicone hose (10/6 mm) with connectors, 0.5 m |
| Distributor | Injector basket Flex 1 |
| Spare parts | Silicone insert for triple distributor, yellow (Ø 19 mm) |
| See also Components [▶ page 180]. | |

Universal adapter incl. 3 inserts and ceramic filter disc

The universal adapter can accommodate a filter disc. Take this into account when reprocessing instruments with an internal diameter ≤ 0.8 mm. Both the reusable metal filter disc and the ceramic filter disc can be used.

Please note the following:

- Do not combine several filter elements to avoid reduced rinse pressure.
- Hollow-body instruments with an internal diameter ≤ 0.8 mm require filter elements.
- If the device is operated with central filters in the pump sump, the filter disc must be removed from the universal adapter.
- Comply with the regular replacement intervals for the filter discs, see [Filter inserts](#) [▶ page 109].
- The “Silicone insert for triple distributor, yellow (Ø 19 mm)” is not intended for use in the universal adapter.

1. Select the green, blue or white silicone insert according to the external diameter of the hollow-body instruments to be reprocessed and insert it into the universal adapter.
2. Screw the adapter onto a connection of the injector rail module.
3. Tighten the adapter by hand.
4. Insert the hollow-body instruments into the universal adapter with the shank facing downwards.

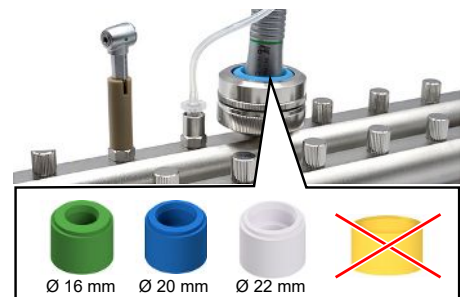

Inserting/replacing the ceramic/metal filter disc

1. Rinse the reusable metal filter disc (pos. d) under running water before first use.
Rinse the new ceramic filter disc (pos. c) briefly under running water.
2. Unscrew the upper part (pos. a) of the universal adapter.
3. Insert the filter disc in the green, blue or white silicone insert (pos. b).
4. Insert the silicone insert into the lower part (pos. e) of the universal adapter with the filter disc facing downwards.
PLEASE NOTE: Insert the silicone insert with the re-usable metal filter disc in the housing. The printed side of the metal filter disc **must always point downwards**.
5. Place the upper section (pos. a) of the universal adapter on the lower section and screw them together hand-tight.

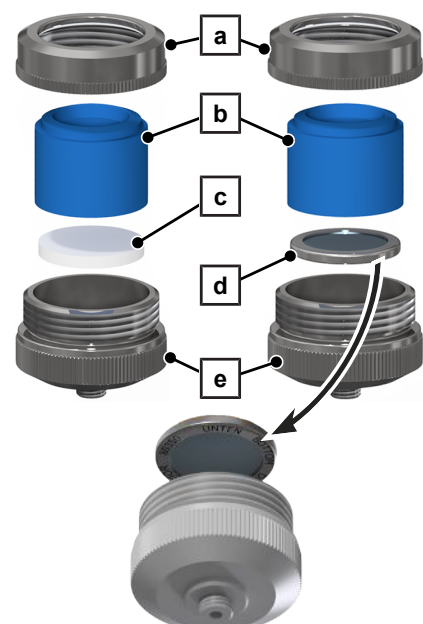

Used with

| Category | Article |
|---|---|
| Injector rail | Injector rail module |
| Filter inserts | Ceramic filter disc |
| | Metal filter disc |
| Adapters for transmission instruments | Distance sleeve |
| Distributor | Injector basket Flex 1 |
| Spare parts | Silicone insert for universal adapter, green/blue/white |
| See also Components [▶ page 180]. | |

Instrument holder for universal adapter

The instrument holder for universal adapters is used to fix the instrument in the universal adapter during reprocessing.

1. Unscrew the upper section of the universal adapter.
2. Place the retaining ring on the lower section of the universal adapter. The hooks must point downwards.
3. Place the upper section of the universal adapter on the lower section and screw them together hand tight.
4. Screw the adapter onto a connection of the injector rail module.
5. Tighten the adapter by hand.
6. Insert the hollow-body instrument into the universal adapter with the shank facing downwards.
7. Fit the silicone strip loosely on the instrument and tauten the strip with the help of the hooks on the retaining ring.



Used with

| Category | Article |
|---|---|
| Adapters for transmission instruments | Universal adapter incl. 3 inserts and ceramic filter disc |
| See also Components [▶ page 180]. | |

Distance sleeve

The distance sleeve is used for maximum utilisation of the injector rail module when using filter disc housings, universal adapters or triple distributors.

1. Screw the distance sleeve onto a connection of the injector rail module.
2. Tighten the distance sleeve by hand.
3. Screw the required adapter onto the distance sleeve.



Used with

| Category | Article |
|---|---|
| Injector rail | Injector rail module |
| Adapters for transmission instruments | Universal adapter incl. 3 inserts and ceramic filter disc |
| | Filter disc housing incl. ceramic filter disc |
| Distributor | Triple distributor incl. ceramic filter disc |
| See also Components [▶ page 180]. | |

Adapter for external spray channels

The adapter is used for rinsing exterior (spray) channels of transmission instruments and other non-standardised hollow-body instruments with small external diameter.

⚠ WARNING

Warning of contamination

Loosely attached silicone hoses can slip from the channels during the program run. The consequence is reduced cleaning performance.

- Check the instruments after the program for slipped silicone hoses.
- If silicone hoses have slipped off, the instrument concerned must be reprocessed again.

1. Screw the adapter for external spray channels onto a connection of the injector rail module, a triple distributor or a filter disc housing.
2. Tighten the adapter by hand with a suitable open-end spanner.
3. Cut the silicone hose supplied to the required length so that it neither sags and forms loops nor is it too taut.
4. Push the free end of the silicone hose onto the (spray) channel to be rinsed.

PLEASE NOTE: Make sure that you connect the silicone hose to the inlet side of the spray channel, i.e. in the direction of flow.



Used with

| Category | Article |
|---|---|
| Injector rail | Injector rail module |
| Adapters for transmission instruments | Filter disc housing incl. ceramic filter disc |
| Distributor | Triple distributor |
| | Triple distributor incl. ceramic filter disc |
| See also Components [▶ page 180]. | |

Distributor

Triple distributor



Triple distributor incl. ceramic filter disc



Injector basket Flex 1

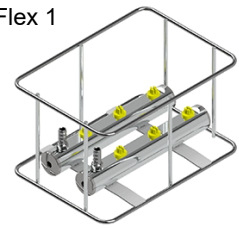

PLEASE NOTE

Sufficiently high rinse pressure is important for the cleaning. If adapters for reprocessing are not fitted with an instrument, then close them off with a suitable silicone closure cap, see [Silicone closure caps](#) [▶ page 111].

Triple distributor

The triple adapter extends the connections of the injector rail module and can be fitted with various adapters (e.g. injector nozzle, hose connections, adapter for Luer/Luer-Lock, etc.).

Please note the following:

- The distributor cannot accommodate a filter disc. Take this into account when reprocessing instruments with an internal diameter ≤ 0.8 mm. If filtered water is needed and a central filter is not available, then use the triple distributor including ceramic filter disc, see [Triple distributor \(incl. ceramic filter disc\)](#) [▶ page 107].
 - The distributor extends the connections of the injector rail module. It may not be combined with other multi-way distributors.
1. Screw the triple distributor onto a connection of the injector rail module.
 2. Tighten the distributor by hand.
 3. Screw other adapters such as injector nozzles or connections for Luer/Luer-Lock and/or hoses onto the triple distributor.
PLEASE NOTE: All connections must be used all the time to ensure correct function.
 4. Close off unused connections with a screw plug.



Used with

| Category | Article |
|---|--|
| Injector rail | Injector rail module |
| Connectors and adapters for instruments | Clamp spring for injector nozzle |
| | Injector nozzle |
| | Luer/Luer-Lock adapter (female) |
| | Luer adapter (male) |
| Closure elements | Luer-Lock adapter (male) |
| | Screw plug for injector rail and distributors |
| Hoses and hose connections | Hose connector (6 mm) with external thread |
| | Silicone hose (10/6 mm) with connectors, 0.5 m |
| See also Components [▶ page 180]. | |

Triple distributor (incl. ceramic filter disc)

The triple adapter extends the connections of the injector rail module and can be fitted with various adapters (e.g. injector nozzle, hose connections, adapter for Luer/Luer-Lock, etc.).

Please note the following:

- Use of filter inserts is necessary for hollow-body instruments with an internal diameter ≤ 0.8 mm. Both the reusable metal filter disc and the ceramic filter disc can be used.
- For hollow-body instruments with an internal diameter > 0.8 mm, remove the filter disc.
- The distributor may not be combined with other multiple distributors.
- If the central filter is used in the device, remove the filter disc from the triple distributor.
- Comply with the regular replacement intervals for the filter inserts, see [Filter inserts](#) [▶ page 109].

1. Screw the triple distributor (pos. a) onto a connection of the injector rail module.
2. Tighten the distributor by hand.
3. Screw other adapters such as injector nozzles or connections for Luer/Luer-Lock and/or hoses onto the triple distributor.
PLEASE NOTE: All connections must be used all the time to ensure correct function.
4. Close off the unused connections with a screw plug (pos. b).

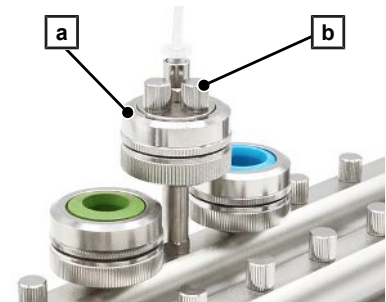

Inserting/replacing the ceramic/metal filter disc

1. Rinse the re-usable metal filter disc (pos. e) under running water before initial use.
Rinse the new ceramic filter disc (pos. d) briefly under running water.
2. Insert the filter disc in the yellow silicone insert (pos. c).
3. Insert the yellow silicone insert in the lower section (pos. f) of the triple distributor with the filter disc pointing downwards.
PLEASE NOTE: Insert the silicone insert with the re-usable metal filter disc in the housing. The printed side of the metal filter disc **must always point downwards**.
4. Place the distributor plate (pos. b) on the yellow silicone insert.
5. Place the upper section (pos. a) of the triple distributor over the distributor plate on the lower section and screw them together hand-tight.

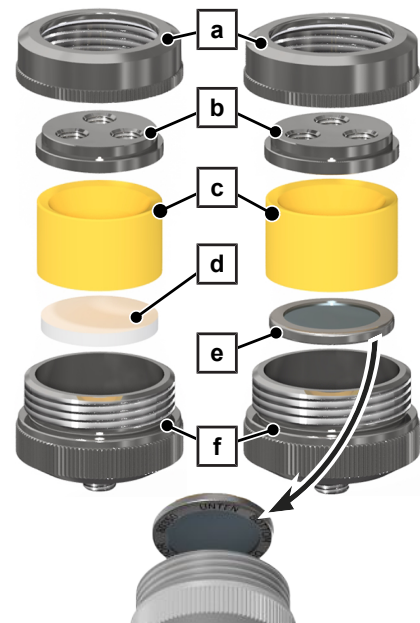

Used with

| Category | Article |
|---|---|
| Injector rail | Injector rail module |
| Connectors and adapters for instruments | Clamp spring for injector nozzle |
| | Injector nozzle (only without use of the filter disc) |
| | Luer/Luer-Lock adapter (female) |
| | Luer adapter (male) |
| Filter inserts | Ceramic filter disc |
| | Metal filter disc |

| Category | Article |
|---|--|
| Closure elements | Screw plug for injector rail and distributors |
| Hoses and hose connections | Hose connector (6 mm) with external thread |
| | Silicone hose (10/6 mm) with connectors, 0.5 m |
| See also Components [▶ page 180]. | |

Injector basket Flex 1

▲ WARNING

Warning of contamination

Failure to cover all the connections on the distributor can impair the cleaning result.

- Always place instruments on the adapters. Seal non-used adapters with the suitable silicone closure cap.
- Use a screw plug to seal unused connections, see [Screw plug for injector rail and distributors](#) [▶ page 112].

Please note the following:

- The injector basket Flex 1 extends the connections of the injector rail module. The injector basket Flex 1 may not be combined with further multi-way distributors.
- The instruments to be reprocessed with the injector basket Flex 1 require fine filtering of the rinse liquor. For this reason, the Flex 1 injector basket may only be used together with the filter housing or the central filter.
- Max. three injector baskets Flex 1 may be inserted.

Reprocessing with a torque spanner connected is possible, provided that this has been approved by the manufacturer for automatic reprocessing.

The injector basket Flex 1 can be stacked on Flex baskets 1-8.

PLEASE NOTE

The use of the injector basket Flex 1 with plastic blind screws is only permitted for the first commissioning, maximum three weeks.

1. **With central filter:** Use two connection hoses (pos. a) to connect the injector basket Flex 1 to two connections of the injector rail module.
2. **Without central filter:** Use two connection hoses (pos. a) to connect the injector basket Flex 1 to two filter disc housings.
3. Screw the adapters for transmission instruments or tips into the unused connections of the Flex 1 injector basket.
4. Tighten the adapters hand-tight.
5. Place the injector basket Flex 1 upside down if drainage of the rinse liquor cannot be ensured.

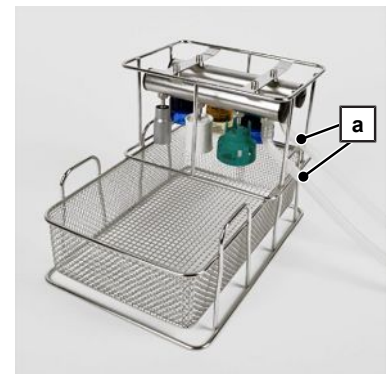

Used with

| Category | Article |
|---|---|
| Injector rail | Injector rail module |
| Stackable holders and baskets (Flex system) | Flex basket 1-8 |
| Connectors and adapters for instruments | Adapters for tips and ultrasonic handpieces |
| Adapters for transmission instruments | all adapters |
| | Filter disc housing incl. ceramic filter disc |
| See also Components [▶ page 180]. | |

Filter inserts

The following views are not to scale.

Central filter for MELAtherm 20



Ceramic filter disc



Metal filter disc



Comply with the following for safe handling:

- Clean all filter inserts in the washer-disinfector before using them for the first time for ophthalmology. To do so, run the **Rinsing** service program without a **load**.
- There may be manufacturing residues on a brand new metal filter disc and a central filter. Before using the components for the first time, check them for manufacturing residues and damage. Clean the metal filter disc and the central filter in the washer-disinfector. To do so, run the **Rinsing** service program without a load.
- Filtering via the central filter or filter discs is necessary for the reprocessing of ophthalmology instruments and hollow-body instruments with an inner diameter ≤ 0.8 mm. Double filtering, i.e. use of the central filter and other filter discs (made of metal or ceramic) is not allowed.

Central filter

The central filter for MELAtherm 20 is used for fine filtering of the rinse liquor. Use the central filter for the reprocessing hollow-body instruments with an inner diameter ≤ 0.8 mm.

The central filter is inserted into the pump sump of the washing chamber and is cleanable, see [Check in the washing chamber](#) [▶ page 160]. MELAG recommends monthly cleaning.

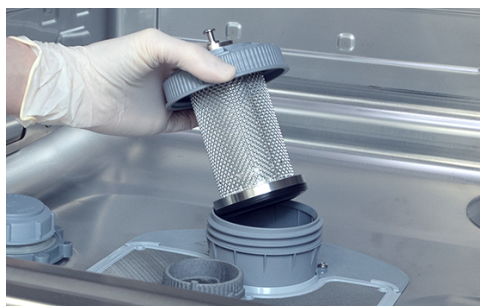

⚠ WARNING

Warning of contamination

If the central filter is used in the pump sump, do not insert any additional filter inserts such as ceramic or metal filter discs. The consequence is reduced rinse pressure.

- Before you insert the central filter into the pump sump, remove any existing filter discs.

Ceramic filter disc

The ceramic filter disc can be used in the filter disc housing, the triple distributor or the universal adapter if there is no central filter inserted in the pump sump of the device.

Please note the following:

- Hollow-body instruments with an internal diameter ≤ 0.8 mm require filter inserts.
- The ceramic filter disc is not suitable for reuse and must be disposed of properly after the named replacement intervals.

Inserting/replacing the filter disc

Replace the ceramic filter disc **every two weeks or after 20 cycles at the latest**. The replacement interval also includes the cycles in which no instruments are placed on the adapters.

Replace the ceramic filter disc according to the [component](#), see [Filter disc housing incl. ceramic filter disc](#) [▶ page 102], [Universal adapter incl. 3 inserts and ceramic filter disc](#) [▶ page 103] or [Triple distributor \(incl. ceramic filter disc\)](#) [▶ page 107].

Used with

| Category | Article |
|---|---|
| Adapters for transmission instruments | Universal adapter incl. 3 inserts and ceramic filter disc |
| | Filter disc housing incl. ceramic filter disc |
| Distributor | Triple distributor incl. ceramic filter disc |
| See also Components [▶ page 180]. | |

Metal filter disc

The reusable metal filter disc can be used in the filter disc housing, triple distributor or universal adapter if there is no central filter inserted in the pump sump of the device.

Inserting a new filter disc

Please note the following:

- Hollow-body instruments with an internal diameter ≤ 0.8 mm require filter inserts.
- Do not use the reusable metal filter disc in ophthalmology. Use the ceramic filter disc instead.

Insert the new metal filter disc according to the ▶component, see [Filter disc housing incl. ceramic filter disc](#) [▶ page 102], [Universal adapter incl. 3 inserts and ceramic filter disc](#) [▶ page 103] or [Triple distributor \(incl. ceramic filter disc\)](#) [▶ page 107].

Cleaning already used filter disc



The reusable metal filter disc is suitable for limited reprocessing.

- Properly dispose of the metal filter disc after using if for reprocessing 20 times.

Clean the metal filter disc **every two weeks or after 20 cycles at the latest**. The interval also includes the cycles in which no instruments are placed on the adapters.

1. Remove coarse dirt particles with a plastic brush while under cold running water.
2. Clean the reusable metal filter disc in an ultrasonic device at 50 °C for approx. 30 min and with cleaning agent (e.g. METHERM 51, recommended metered quantity 10 ml/l) in de-ionised water. Comply with the manufacturer's instructions for the respective ultrasonic device.
3. Rinse the reusable metal filter disc under cold running water.



Warning of contamination

In rare cases, dirt particles can remain on the reusable metal filter disc after ultrasonic cleaning and can work loose during reprocessing.

- After reprocessing, visually check the metal filter disc for remaining residues.
- If there are any visible residues, reprocess the metal filter disc again.

4. If the reusable metal filter disc is not used directly, it must be dried and then stored in a dry location.

Used with

| Category | Article |
|---|---|
| Adapters for transmission instruments | Filter disc housing incl. ceramic filter disc |
| | Universal adapter incl. 3 inserts and ceramic filter disc |
| Distributor | Triple distributor incl. ceramic filter disc |
| See also Components [▶ page 180]. | |

Closure elements

The following views are not to scale.

Silicone closure cap, green



Silicone closure cap, blue



Silicone closure cap, white



Screw plug for injector rail and distributors



Closure (male) for Luer-Lock



Closure (female) for Luer/Luer-Lock



Silicone closure caps

The silicone closure caps are used to close off adapters if they are not fitted with an instrument.

Note that pushing on and pulling off in a dry state can be sluggish.

- ▶ Slide the silicone closure cap onto the adapter until it fits tightly.
PLEASE NOTE: Do not push the silicone closure cap completely onto the adapter so that you can pull it off more easily after use.



Used with

| Category | Article | |
|---|---|---------------------------------|
| Connectors and adapters for instruments | Injector nozzle | for Silicone closure cap, green |
| | Adapters for tips and ultrasonic handpieces | |
| | Adapter for KaVo eScaler | |
| Adapters for transmission instruments | Adapter for Sirona T1 Classic | for Silicone closure cap, blue |
| | Adapter for turbines W&H connector (Roto Quick) | |
| | Adapter for turbines Sirona connector | |
| | Adapter for turbines KaVo connector (MULTIflex) | |
| Hoses and hose connections | Hose connector (6 mm) with external thread | |
| Adapters for transmission instruments | Adapter for ISO connector (INTRA) | for Silicone closure cap, white |
| | Adapter for turbines NSK connector | |
| | Adapter for EMS AIR-FLOW Handy 3.0 | |
| | Adapter for EMS AIR-FLOW Prophylaxis Master | |
| | Adapter for KaVo/BienAir contra angle heads | |
| | Adapter for NSK Varios Combi Pro (airflow) | |
| | Adapter for Sirona Sprayvit nozzle | |
| | Adapter for KaVo multifunctional cannula | |
| | Adapter for MyLunos powder water jet nozzle | |
| See also Components [▶ page 180]. | | |

Screw plug for injector rail and distributors

The screw plug is used to close off unused connections of the injector rail module or distributor.

- ▶ Screw the screw plug into a connection that is not in use.

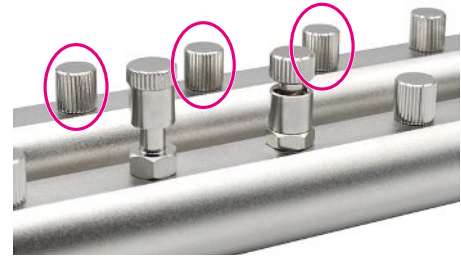

Used with

| Category | Article |
|---|--|
| Injector rail | Injector rail module |
| Distributor | Triple distributor |
| | Triple distributor incl. ceramic filter disc |
| See also Components [▶ page 180]. | |

Closure (male) for Luer-Lock

The closure (male) for Luer-Lock is used to close off an adapter for Luer-Lock (female).

- ▶ Screw the closure onto an adapter for Luer-Lock (e.g. when not in use) to seal it and thus prevent the rinse pressure from dropping.

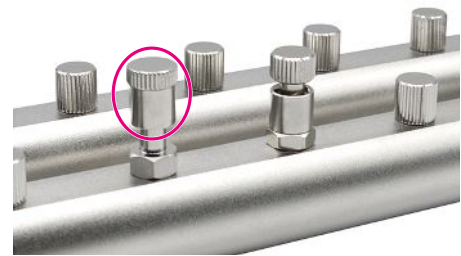

Used with

| Category | Article |
|---|---------------------------------|
| Connectors and adapters for instruments | Luer/Luer-Lock adapter (female) |
| See also Components [▶ page 180]. | |

Closure (female) for Luer/Luer-Lock

The closure (female) for Luer/Luer-Lock is used to close off an adapter for Luer-Lock (male).

- ▶ Screw the closure onto an adapter for Luer/Luer-Lock (e.g. if not used) to close it off and to avoid a drop in rinse pressure.

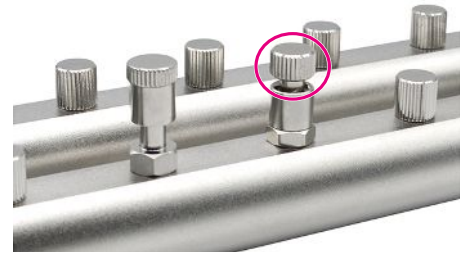

Used with

| Category | Article |
|---|--------------------------|
| Connectors and adapters for instruments | Luer adapter (male) |
| | Luer-Lock adapter (male) |
| See also Components [▶ page 180]. | |

Hoses and hose connections

The following views are not to scale.

Hose connector (6 mm) with external thread



Hose connector (6 mm) with internal thread



Silicone hose (10/6 mm), 2 m



Silicone hose (10/6 mm) with connectors, 0.5 m



Please note the following:

- Install the hoses free of kinks and sacks.
- Keep the hoses as short as possible. Water can accumulate in long hoses.
- Make sure that hoses are not pinched off by other [components](#) or instruments.
- Do not close hoses.
- Remove hoses when not in use.
- Check the hoses, connections and instruments before and after reprocessing to ensure that they are tight. If a hose, connection or instrument has come loose, reprocess the instrument again.

Hose connector (6 mm) with external thread

The hose connection connects hoses with an internal diameter of 6 mm to the injector rail module, the filter disc housing or a distributor.

1. Screw the hose connector into a connection of the injector rail module, the filter disc housing or a distributor.
2. Tighten the hose connector hand-tight.

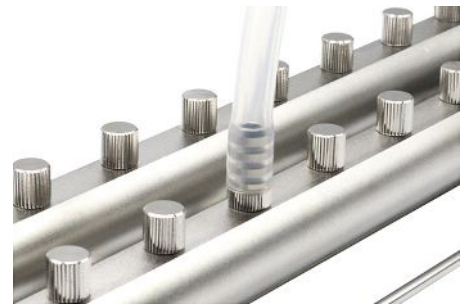

PLEASE NOTE

The hose connection must always be used for faultless function without reduced rinse pressure.

- Replace unused hose connections with a screw plug.

▶ If the connection is not fitted with an instrument, close off the hose connection with a blue silicone closure cap. For further information on use of the silicone closure cap, see [Silicone closure caps](#) [▶ page 111].

Used with

| Category | Article |
|---|---|
| Adapters for transmission instruments | Filter disc housing incl. ceramic filter disc |
| Distributor | Triple distributor |
| | Triple distributor incl. ceramic filter disc |
| Closure elements | Silicone closure cap, blue |
| Hoses and hose connections | Silicone hose (10/6 mm), 2 m |
| See also Components [▶ page 180]. | |

Hose connector (6 mm) with internal thread

The hose connector with internal thread can be used to relocate a connection of the injector rail module through a hose with internal diameter of 6 mm, e.g. if very long hollow bodies are to be reprocessed, for which there is only space in the Flex basket if the bodies are positioned horizontally/lying down.

1. Plug the hose connection (pos. b) onto the free end of the hose.
2. Connect the Adapter (pos. a) to the internal thread.

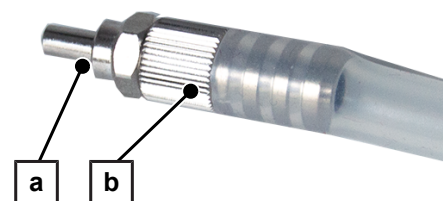

Used with

| Category | Article |
|---|------------------------------|
| Hoses and hose connections | Silicone hose (10/6 mm), 2 m |
| See also Components [▶ page 180]. | |

Silicone hose without/with connections

The **silicone hose without connections** is used to connect connections to instruments or to relocate connections of the injector rail module spatially. Instruments with a hose connection can also be pressed into the hose.

The **silicone hose with connections** enables connections of the injector rail module to be relocated spatially, e.g. If very long hollow bodies are to be reprocessed for which there is only space in a Flex basket if the bodies are lying down/ horizontal. The silicone hose is fitted with one connection with internal and external thread.

1. Cut the hose to the required length. **PLEASE NOTE:** Avoid unnecessarily long hoses.
2. Connect the hose without connections to the matching hose connection.
3. Remove hoses when not in use.

Used with

| Category | Article | |
|---|---|--|
| Hoses and hose connections | Hose connector (6 mm) with external thread | for Silicone hose (10/6 mm), 2 m |
| | Hose connector (6 mm) with internal thread | |
| Stackable holders and baskets (Flex system) | Flex basket 6 | for Silicone hose (10/6 mm) with connectors, 0.5 m |
| Connectors and adapters for instruments | Rinse sleeve incl. 5 inserts | |
| Adapters for transmission instruments | Filter disc housing incl. ceramic filter disc | |
| Distributor | Triple distributor | |
| | Triple distributor incl. ceramic filter disc | |
| See also Components [▶ page 180]. | | |

DIN sieve trolley

The following view is not to scale.

MELAtherm 20
DIN sieve trolley



The DIN sieve trolley enables instruments to be held in DIN sieves for reprocessing in the MELAtherm 20 by means of automated cleaning and thermal disinfection.

The DIN sieve trolley can be fitted with up to eight DIN sieves — two DIN sieves per level, for the reprocessing of thermostable solid instruments.

Application

Inside the washing chamber, on the right-hand side of the rear wall, is the connector for the water inlet of the middle rinse arm on the DIN sieve trolley.

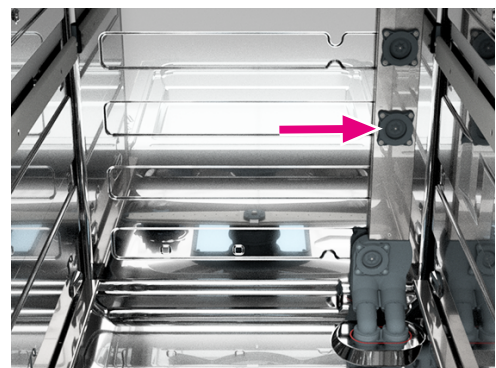

1. Place the empty DIN sieve trolley on the open door so that the handle (pos. b) of the trolley faces the front and the connection fitting is at the rear.
2. Lay the instruments to be reprocessed in the DIN sieves (pos. a).
3. Push the DIN sieves (pos. a) into the trolley from the front.
4. Push the DIN sieve trolley into the washing chamber until the connection fitting of the trolley docks onto the connector.

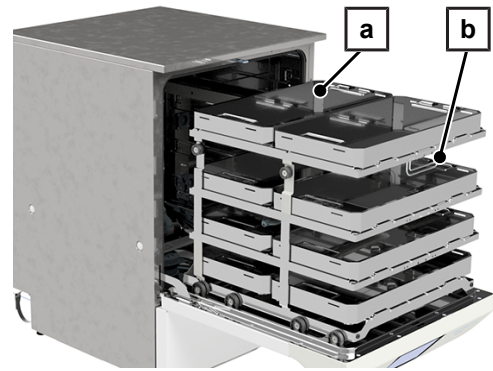

Technical data

| | | |
|---|---|-------------------------|
| DIN sieve trolley | empty weight (without DIN sieves) | approx. 8 kg |
| | max. allowed load | 20 kg |
| | max. allowed total weight ^{*)} | 40 kg |
| DIN sieve | max. dimensions (L x W x H) | 485 mm x 253 mm x 56 mm |
| *) Total weight = DIN sieve trolley + DIN sieves + load | | |

9 Loading the device

Principles of the load configuration

The 8-segment principle

All ▶components for the ▶reprocessing are placed in the upper basket and in the lower basket with or without injector rail module. To use the space optimally, the area is divided into eight segments.

The size of all holders, instrument, washing and Flex baskets corresponds to one or several segments.

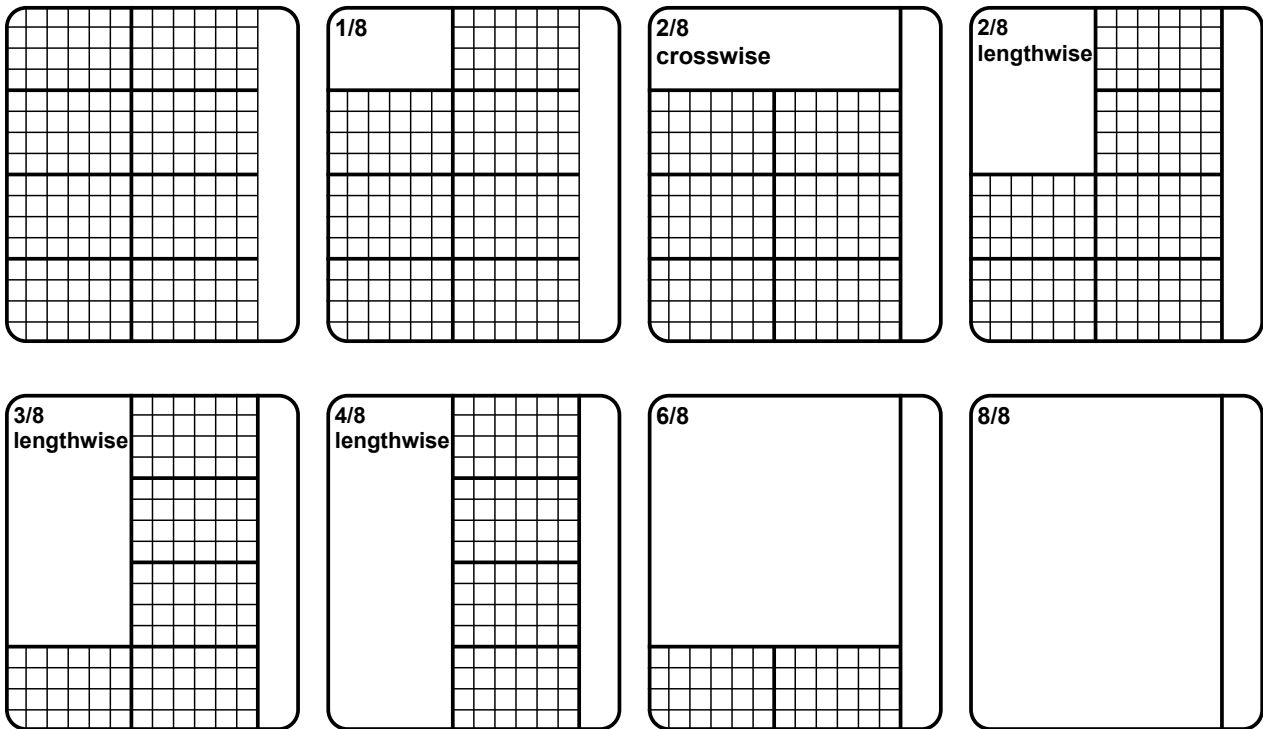

Application

- ▶ Always position the holders, instrument, washing and Flex baskets on the left or right according to the 8-segment principle. MELAG recommends not positioning the components in the middle.

The Flex system

The Flex system consists of instrument baskets of various sizes. The Flex baskets can be combined with each other in variable ways and stacked. This system ensures the optimal use of space in the washing chamber of the washer-disinfector.

▲ WARNING

Warning of unwashed areas

If more than two Flex baskets are stacked on top of each other, unwashed areas can affect cleaning performance.

- Stack no more than a max. of two Flex baskets.

Flex baskets may be stacked with a maximum of two levels. Top frames for stackable Flex baskets can also be used. The example shows one of many possible combinations.

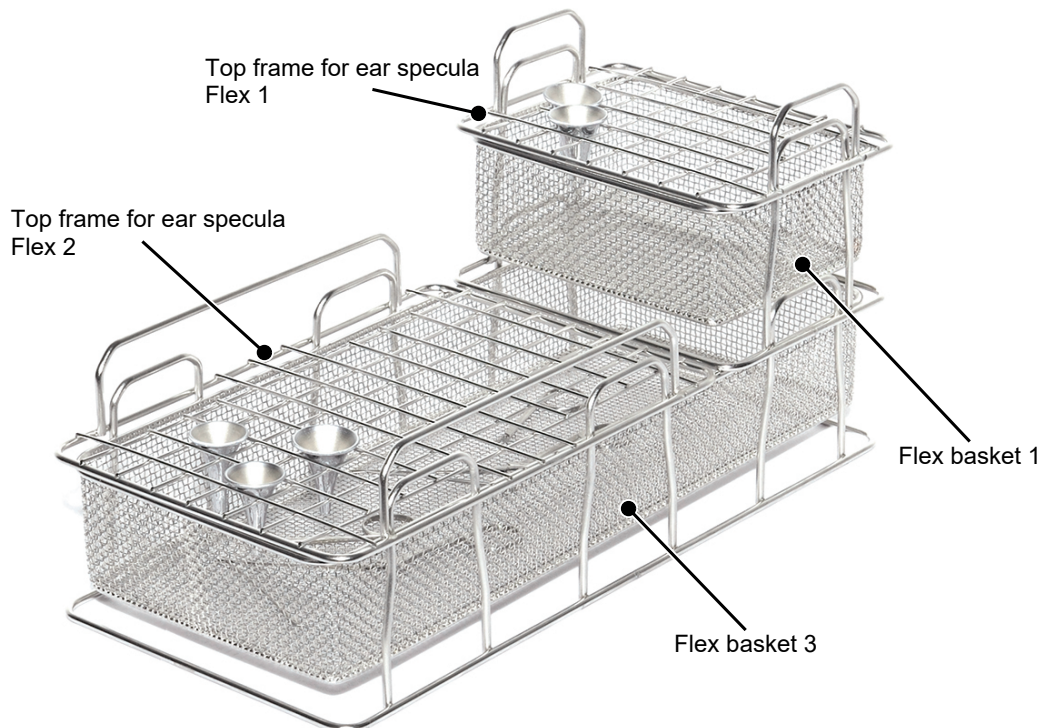

Examples for the basic configuration

Basic configuration for the dental practice

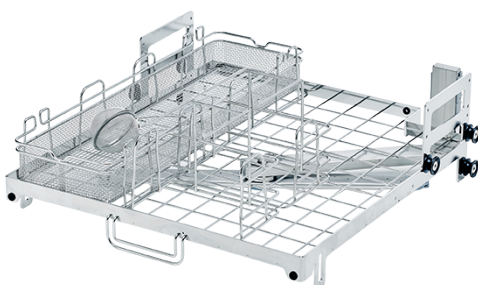

- Upper basket
- Flex basket 4
- Small parts basket Standard
- 2x Holder for impression trays and instruments with joints



- Lower basket
- Injector rail module
- Universal holder Flex 4
- 4x MELAstore Tray 100 (28 x 17.9 x 3.2 cm)
- Instrument basket G

Basic configuration for oral and maxillofacial surgery (OMFS)

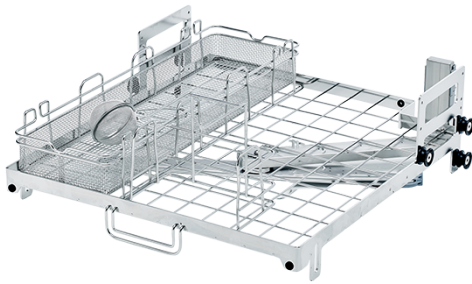

Upper basket
 Holder for impression trays and instruments with joints
 Flex basket 4
 Small parts basket Standard



Lower basket
 Injector rail module
 Universal holder Flex 4
 Universal holder Flex 3
 Instrument basket compact

Basic configuration for the orthodontic practice (KFO)

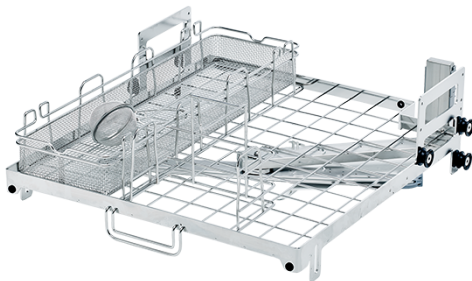

Upper basket
 Holder for impression trays and instruments with joints
 Flex basket 4
 Small parts basket Standard

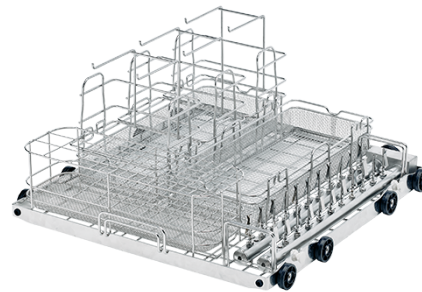

Lower basket
 Injector rail module
 2x Flex basket 3
 3x Holder for impression trays and instruments with joints
 Instrument basket standard

Basic configuration for the ophthalmological practice

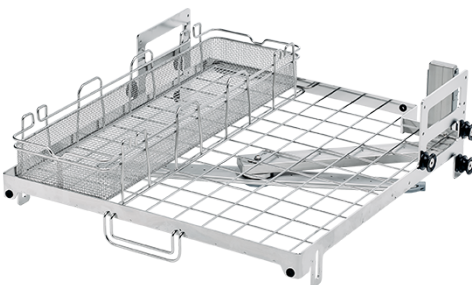

Upper basket
 Flex basket 4



Lower basket
 Injector rail module
 2x Universal holder Flex 4
 8x MELAstare Tray Ophthalmology

Basic configuration for the gynaecological practice

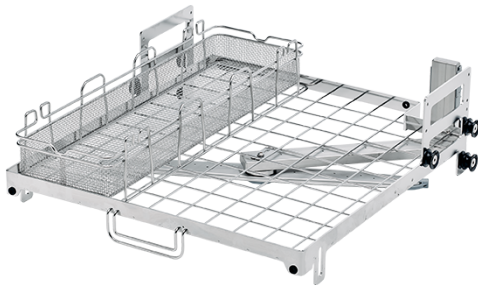

Upper basket
Flex basket 4

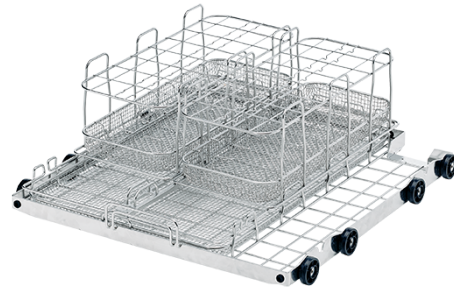

Lower basket
Flex basket 8
Flex basket specula

Basic configuration for the ear, nose and throat (otolaryngology) practice (ENT)

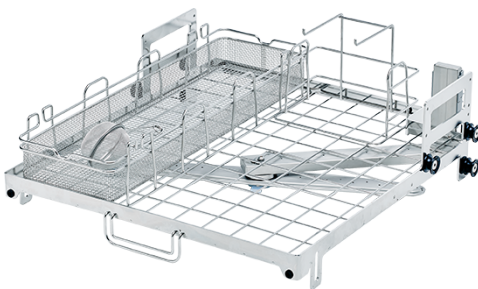

Upper basket
Holder for impression trays and instruments with joints
Flex basket 4
Small parts basket Standard

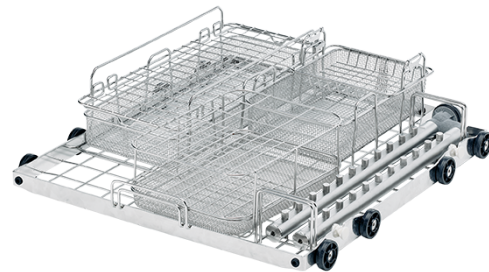

Lower basket
Injector rail module
Flex basket 4
Top frame for nasal specula Flex 1 incl. 2 fixing clamps
Instrument basket G
Flex basket 2
Top frame for ear specula Flex 3 (mesh size 20 mm)

Basic configuration for the general medical practice/surgery

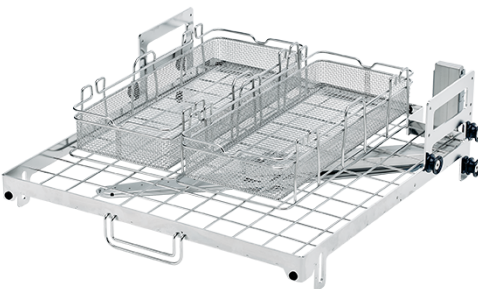

Upper basket
2x Flex basket 3

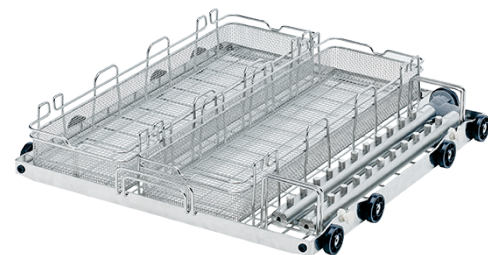

Lower basket
Injector rail module
2x Flex basket 4

Loading instructions

NOTICE**Warning of material damage caused by unsuitable instruments**

Some brands are only authorised for thermal disinfection from a specific year of manufacture.

- Only reprocess instruments designed by their manufacturer for automatic reprocessing in a washer-disinfector.
- Always follow the instructions of the respective instrument manufacturer.

Please note the following:

- Make sure that the load does not cause any unwashed areas. When using third-party wash trays, make sure that the design of the wash trays (e.g. large covered areas) does not cause unwashed areas.
- Open instruments with hinges that cannot be dismantled or instruments that can be closed (e.g. tweezers) for reprocessing.
- Place scratch-sensitive instruments (e.g. dental mirrors) separately with sufficient distance between them. Loose preparation in a wash tray can cause damage (e.g. to the mirror surface).
- If you use third-party components for the reprocessing of instruments in the device, ensure the combinability of these third-party components with the device and instruments.
- Comply with pre-determined loading patterns established within the scope of the validation procedure.

Type of load

When loading the device, note the other information in this manual.

Only use the loading pattern specified and approved within the scope of the validation.

Keep to the maximum allowed quantity for the load. The data include the self-weight of the basis baskets, the instruments and other components.

- Upper basket: max. 15 kg
- Lower basket: max. 20 kg

You can clean and disinfect the following types of load:

- solid instruments,
- hollow-body instrument e. g. aspirator tips, which are fixed onto injector nozzles or
- transmission instruments e. g. handpieces and contra angles by using the adapter

The **reprocessing of certain instruments** may require additional ▶**components** (not available from MELAG). The operator is responsible for validating the procedure in combination with special load components. It is particularly important that feed lines to hollow-body instruments are kink-free and as short as possible.

10 Cleaning and disinfection

Comply with the following for safe handling:



- Only reprocess instruments designed by their manufacturer for automated [▶reprocessing](#) in a washer-disinfector. Comply with the instructions issued by the instrument manufacturer in accordance with [▶EN ISO 17664](#). It is especially important to comply with the specifications from the instrument manufacturer regarding cleaning instruments for the first time after purchasing new instruments.
- Comply with the specifications of the national standards and directives pertaining to the reprocessing of instruments, the instrument manufacturer's reprocessing instructions and those from the [▶AKI](#).
- MELAG recommends that the device not be operated while it is unattended (e.g. over night). If you want to operate the device while it is unattended, then make sure that the automatic door opening is activated and the water stop is installed.
- Note that some condensation can form on the floor during operation. The quantity of condensate is influenced by the ambient conditions (e.g. flooring) and the load (e.g. full load, solid load) in the device.

Instructions for reprocessing and use

PLEASE NOTE

Observe national regulations regarding automatic reprocessing.

Please note the following:

- Clean all filter inserts in the washer-disinfector before using them for the first time for ophthalmology. To do so, run the **Rinsing** service program without a [▶load](#).
- Only use components and instruments made of stainless steel or other non-corroding materials.
- Only reprocess thermostable instruments in the washer-disinfector which have been approved by the manufacturer. As a rule, these instruments are labelled directly or in the reprocessing instructions with the following symbol: 
- Do not reprocess any single-use instruments. Single-use instruments are usually marked with the following symbol: 
- Follow the other instructions in this manual, see [Reprocessing hollow-body instruments](#) [[▶ page 124](#)], [Reprocessing dental transmission instruments](#) [[▶ page 125](#)] and [Reprocessing ophthalmological instruments](#) [[▶ page 125](#)].
- Note that instruments, instrument baskets and washing baskets and other components can still be hot after the reprocessing program.

Routine check after reprocessing

Please note the following:

- The instruments must be completely cleaned and patent (unblocked).
- Check adapters, hoses, connections and instruments for tight fit. Renewed reprocessing is necessary if an adapter, hose, connection or instrument has loosened.
- Check the closure elements (e.g. screw plugs or silicone closure caps) on the connections and adapters for tight fit. If a closure element has loosened, retighten it or insert it correctly, see [Closure elements](#) [[▶ page 111](#)].
- Reprocess the respective instrument if the arrangement of the instruments has changed during reprocessing.

Optimising the cleaning performance

Do not use any preparations (e.g. dishwasher cleaners, household rinse aids or fragrance tabs) developed for commercially available dishwashers or other “home remedies” (e.g. aluminium foil as a stain preventative, vinegar or baking soda to improve odour) in the washer-disinfector. These substances impair the reprocessing process and can cause damage to both the device and the instruments. When metered correctly, the process agents specified by the washer-disinfector achieve the best possible cleaning effects and render superfluous the use of additional agents.

Wet/dry storage

Please note the following:

- Store used instruments in a dry place. Ensure that they are stored protected from light and heat. Keep the storage duration as short as possible.
- Instruments which have organic residue (e.g. blood) after patient treatment can benefit from presoaking in a suitable treatment solution. Check the compatibility of the wet disposal process agents with the [▶process agents](#) of the washer-disinfector. Otherwise, choose dry storage.
- If you carry out presoaking, rinse the instruments thoroughly with running water before [▶reprocessing](#) in the washer-disinfector to prevent the solution from entering the device.
- Instruments may not be soaked overnight in water. Soaking in demineralised/distilled water can also cause damage connected with treatment residue (blood, etc.).

Preparation and pre-cleaning

Please note the following:

- [▶KRINKO/▶BfArM](#) (2012) recommend that instruments of the risk class “Semi-critical B” and “Critical B” are subjected to precleaning directly after use.
- Remove water-insoluble treatment substances (e.g. dental cement, root canal disinfectants, alginates or silicones) directly after use by manual cleaning. Consult the product data sheets of the treatment substances.
- Other substances can also necessitate manual precleaning. These include ultrasound gels and other auxiliary substances.
- If instruments are to be subject to manual preparation for cleaning, ensure that no media or tools/resources are deployed which could damage their surface. Never use any aggressive cleaning agents, wire or brass wire brushes or metal scourers. Information regarding correct instrument reprocessing is available from your instrument manufacturer.
- Check hollow bodies (transmission instruments, cannulas, etc.) for free passage. Observe the department-specific instructions in this manual.
- Disassemble dismountable instruments for reprocessing according to the manufacturer’s instructions.
- Remove corroded or defective instruments. Crusted instruments must be subject to a basic cleaning or repair.
- The complete cleaning and disinfection of surgical aspirators requires manual pre-cleaning of the interior lumen. Subsequent suction (e.g. using the dental unit) of a minimum of 200 ml water through the surgical aspirator immediately or 10 min (at the latest) after treatment will achieve sufficient pre-cleaning. A comparable or more intensive pre-cleaning is permissible.

Process agents

Please note the following:

- To avoid cleaning problems, you may only use the process agents matched with each other that were set by the [▶authorised service technician](#) when setting up the washer-disinfector.
- Information on the set product can be found in the record of installation or on the process agent tag directly on the container.

Arranging the load

The basis baskets including holders, instrument baskets and/or washing baskets must be used to arrange the load. The lower basket with injector rail module is required for the [▶reprocessing](#) of hollow-body instruments.

For other [▶components](#) and explanations on their use such as holders for washing baskets, instrument baskets, etc., see [Components for reprocessing](#) [▶](#) page 56].

Please note the following:

- Empty all residual liquids from containers before arranging them in the device. Rinse off any liquids (e.g. disinfectant solutions) thoroughly.
- Never lay or place individual instruments directly in the basis baskets. Use the instrument baskets or washing baskets (e.g. MELAstore Tray).
- Make sure that instruments do not protrude at the sides of the instrument baskets or the basis baskets. Protruding instruments can damage the gasket and the surface of the door or the side walls of the washing chamber. The instruments can break off.
- Place hollow-body instruments in the device in such a way as to ensure safe rinsing. If necessary, use the components specially developed for the reprocessing of hollow-body instruments, e.g. Injector nozzle, Luer connection, adapter, etc., see [Components for reprocessing](#) [▶](#) page 56].
- Avoid blockages of the rinse arm from instruments protruding upwards or downwards. The rinse arms must be able to rotate freely.
- Ensure the instruments are correctly arranged. Avoid unwashed areas and multiple stacking of the instruments. Use the components for fixing the instruments so that they do not slip during reprocessing.
- Arrange all containers such as kidney dishes, etc. with their opening pointing downwards.
- Position items with openings or recesses at an angle so that water can run off them.

Reprocessing hollow-body instruments

▲ WARNING

Warning of contamination from insufficient disinfection

Residues that prevent patency in the hollow-body instruments can impair the disinfection.

- Check hollow-body instruments for patency before and after reprocessing.

▲ WARNING

Warning of contamination from insufficient disinfection

If using multiple distributors or the injector rail module, all connections must be used. Only then can correct function be ensured.

- Close off unused connections.

▲ WARNING

Warning of contamination from insufficient disinfection

Fine filtering of the rinse liquor is required if hollow-body instruments with an internal diameter ≤ 0.8 mm are to be reprocessed.

- For reprocessing, use a filter insert or the central filter.

Note the following:

- Comply with the specifications of the instrument manufacturer.
- Rinse all hollow-body instruments after use with patients or before automatic reprocessing.
- Only reprocess hollow-body instruments that ensure sufficient and reproducible rinsing. Remove instruments with a recognisably reduced throughflow.
- Only use the MELAG adapters for the injector rail module for the [▶reprocessing](#) of hollow-body instrument. The suitability of a hollow-body instrument for the respective adapters and the sufficient rinsing can only be proven by validation.
- Check the connection between the adapter and the hollow-body instrument for stability both before and after reprocessing. If the connection work has loosened after reprocessing, the instruments must be reprocessed again.

- When using filter inserts, keep to the cleaning and replacement intervals, see [Filter inserts](#) [▶ page 109].
- When reprocessing dental and ophthalmologic transmission instruments, observe and comply with the special reprocessing instructions in [Reprocessing dental transmission instruments](#) [▶ page 125] and [Reprocessing ophthalmological instruments](#) [▶ page 125].

Rule for use of filters or filter discs:

| Diameter of the inner lumen | Use of a filter |
|-----------------------------|--|
| ≤ 0.8 mm | Filter required, e. g. triple distributor incl. ceramic filter disc (art. no. ME73903) |
| > 0.8 mm | No filter required, direct connection of the adapter to the injector rail is possible |

Reprocessing dental transmission instruments

Note the following:

- Comply with the specifications of the instrument manufacturer.
- The exterior surfaces of the handpieces and contra angles should be free of all water-insoluble residue e. g. dental cement.
- The air and spray channels must be entirely clear (unblocked).
- Prevent soiling from drying, especially on and in the handpieces and contra angles.
- Use a citric acid based ▶neutraliser for the ▶reprocessing of dental transmission instruments.
- Reprocess transmission instruments on the adapters provided for this purpose, see [Adapters for transmission instruments](#) [▶ page 93]. Make sure that the adapters are connected correctly.
- Dry the hollow-body instruments after reprocessing using medical compressed air.

Care of the instruments and adapters

1. Immediately after successful cleaning and disinfection, redry the spray, air and water channels using medical compressed air.
2. Carry out maintenance with suitable care products and oils. MELAG recommends the Care Oil Spray.
3. Check the adapters for transmission instruments at regular intervals for possible soiling.
4. If necessary, rinse the individual parts of the adapters under running water.
5. Rub the silicone inserts of the universal adapters with a damp, lint-free cloth.

Reprocessing ophthalmological instruments

Comply with specific national recommendations for the cleaning of ▶medical devices under the aspect of decontamination of infectious prion protein (CJD).

▲ WARNING

Warning of contamination from biological interaction

Devices used to reprocess ophthalmologic instruments may only be used exclusively for this purpose.

- Do not reprocess any instruments which are used for posterior segment surgery (contact with retinal tissue, sub-retinal fluid and the optical nerve).
- Equip the devices with a suitable filter system, e.g. the central filter.

▲ WARNING

Warning of eye damage from rinse aid

Do not use ▶rinse aid for reprocessing ophthalmic instruments!

ⓘ PLEASE NOTE

Use de-ionised water to reprocess ophthalmological instruments.

- To this end, connect a mixed bed resin cartridge.

Suitable program

Reprocess ophthalmological instruments in the **Ophthalm** program. Only this program monitors the **conductivity** of the water during the disinfection phase, which ensures safe residual conductivity for use on the eye.

Note the following:

- Comply with the specifications of the instrument manufacturer.
- Use a mildly-alkaline **cleaning agent** for cleaning and a citric acid-based **neutraliser** for neutralising.
- Rinse all hollow-body instruments after use on patients or before automated reprocessing with **DI water**.
- Only reprocess hollow-body instruments that ensure sufficient and reproducible rinsing. Remove instruments with a recognisably reduced throughflow.
- Connect all hollow bodies properly with the adapters provided.
- Ensure that plugs and/or cables from Phaco handpieces are not able to slip through the basis basket, otherwise the rinse arm can become blocked.
- Try to prevent soiling from drying or encrusting on and in the instruments.
- Dry the ophthalmological instruments after reprocessing using medical compressed air.
- When using rinsing systems, close off individual outlets that are not used, also with suitable **components**.

Instrument care

Follow the instructions of the instrument manufacturer for the care and maintenance of the instruments.

Routine check





Perform a routine check of the **pH value** after reprocessing the hollow-body instruments.

1. Blow through the hollow-body instrument with medical compressed air onto indicator paper (e.g. from Macherey-Nagel: PEHANON pH 4.0-9.0). The measurement accuracy must amount to or exceed 0.5.
2. Compare the value displayed on the indicator paper with the pH value of the final rinse water from the previous performance qualification.
3. In case of deviations, please contact customer service.





Selecting the program

Select the program according to how heavily the load is soiled and which particular requirements apply. Comply with the findings from the validation.

Refer to the following table to find out which load is suitable for which reprocessing program. The operating times given are average values and apply to the recommended running water pressure at a cold water temperature of 15 °C.

| Reprocessing program | Symbol | Type of instruments/degree of soiling | Operating time without drying time ^{*)} |
|----------------------|---|---|--|
| Universal |  | <ul style="list-style-type: none"> • For a normally soiled load with injector rail module and trays (e.g. MELAstore Trays) | 42 min |
| Universal+ |  | <ul style="list-style-type: none"> • For a particularly complex load, e.g. with increased unwashed areas caused by stacked washing baskets (e.g. MELAstore Trays) • Like the Universal program, with additional precleaning and longer cleaning time | 56 min |
| Intensive |  | <ul style="list-style-type: none"> • For a heavily soiled load • Like the Universal+ program, however, with more intensive cleaning and higher amount of metered cleaning agent | 59 min |
| Ophthalm |  | <ul style="list-style-type: none"> • For ophthalmology instruments • Like the Universal+ program, however, with intermediate rinsing twice and without rinse aid | 59 min |

^{*)} under optimal installation and load conditions

| Service program ^{*)} | Symbol | Use | Operating time |
|---|---|--|----------------|
| Rinsing |  | <ul style="list-style-type: none"> For cold precleaning of heavily soiled instruments PLEASE NOTE: Start a reprocessing program soon. For rinsing out the washing chamber after filling the salt container; without process agents, no disinfection | 7 min |
| Draining |  | <ul style="list-style-type: none"> For pumping residual water out of the washing chamber | 1 min |
| Measuring conductivity |  | <ul style="list-style-type: none"> For checking the conductivity of the DI water | 2:30 min |
| Air removal |  | <ul style="list-style-type: none"> For removing air bubbles from the metering system, e.g. after changing the process agents product During decommissioning and commissioning | 13 min |
| Regenerating |  | <ul style="list-style-type: none"> For regenerating the device's internal softening unit PLEASE NOTE: If the water hardness is low, the service program is cancelled with a warning. | 13 min |
| *) There is no reprocessing in the service program. | | | |

Starting and monitoring the program

The following requirements must be met to ensure rinsing performance before every program start:

- ✓ The process agent container and the storage container are sufficiently full.
- ✓ The rinse arms can be turned freely.
- ✓ The nozzles or adapters of the injector rail module are clean.
- ✓ The replacement interval of the filter discs is kept to.
- ✓ The load is arranged correctly in the device.
- ✓ Baskets and inserts are inserted correctly.
- ▶ Start a reprocessing program immediately or change the program options first and then start it.
- ↳ When the program starts, any logged in administrator is logged out automatically.

Start program

1. Select the program as indicated in the Program overview, see [Selecting the program](#) ▶ page 126].
2. Navigate in the menu to the required program.
3. Press **Start**.
PLEASE NOTE: If **start** is not displayed, no program options are set. Press **options** and make a setting.
4. If necessary, enter your user PIN for the authentication.

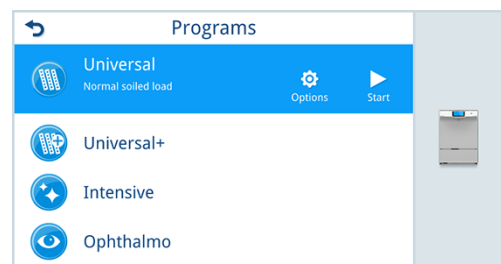

Program options

The setting(s) in the program options are active once for the currently selected program. As soon as the program run is finished, the settings from the **Settings** menu are automatically adopted.

If you want to run a program without upper basket and thus without middle rinse arm, then you must deactivate the **Middle rinse arm monitoring** before each program start.

The following must be fulfilled or present:

- ✓ The **Programs** menu is open.

1. Press the required program and then press **Options**.

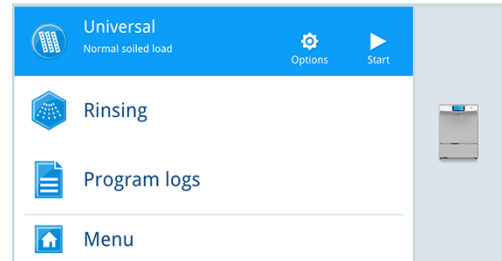

2. Press  if you want to change the monitoring setting for the middle rinse arm.

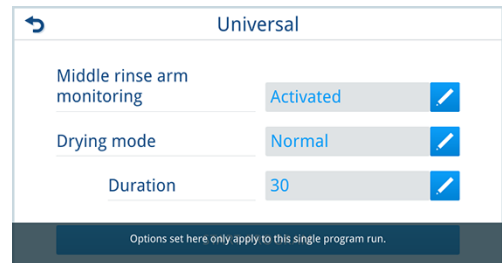

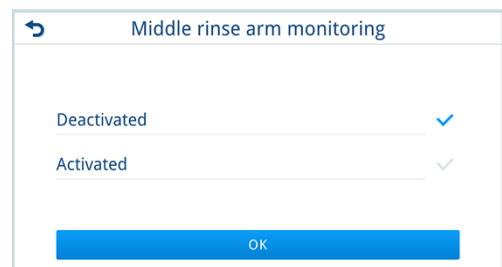

3. Select **Deactivated** (blue checkmark) and press **OK**.



4. If no further settings are to be made, press **START PROGRAM**.

If drying is to be performed differently from the settings in the **Settings** menu, you can change the drying mode and/or the duration of the drying mode for the current program run.

The current settings are shown in the view.

5. Press , to change the **Drying mode**.
6. Press , to change the **Duration** of the drying mode.

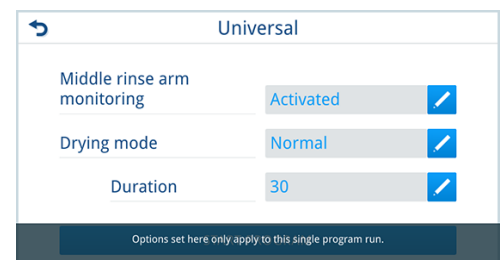

7. Select the drying mode (blue checkmark) and press **OK**.

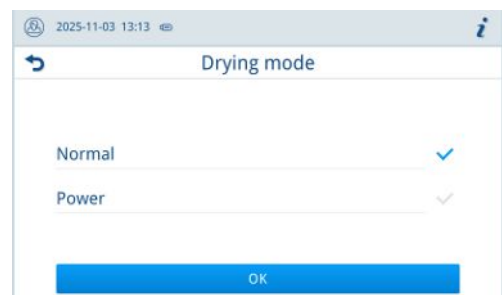

- Select the drying duration using the adjustment wheel and press **OK**. The duration is specified in minutes.

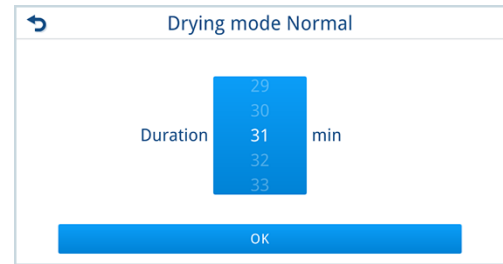

- Press **START PROGRAM**.

Monitoring the program

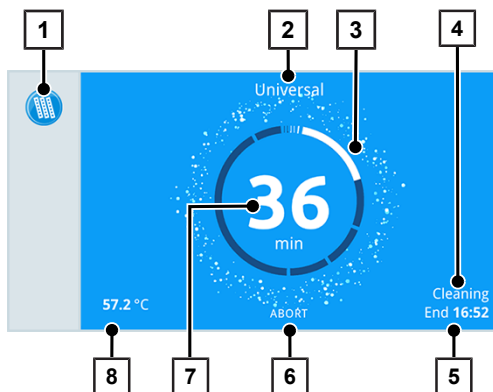

- Function area (minimised display): running program
- Program name
- Busy indicator
- Partial cycle
- Estimated end of the program
- Cancel/Exit button
- Remaining run time (remaining program duration)
- Program parameters (temperature)

If the display is not touched, the display maximises itself and is superimposed on (hides) the function area. Touch the display to show the function area.

Prematurely ending or cancelling the program

⚠ WARNING

Warning of germ formation

If you end or cancel a program prematurely, the consequence is less drying and residual moisture on the instruments.

- Check the instruments and dry them manually if necessary.

⚠ CAUTION

Warning of burns

After a premature program end or cancelled program, the instruments and the washing chamber can still be hot.

- Allow the device to cool before removing the instruments.
- Wear suitable protective gloves.

| Program | Description |
|-----------------|---|
| end prematurely | If reprocessing program is ended after the Drying partial cycle begins, then it is deemed to be successful . |
| cancel | If a reprocessing program is cancelled before the Drying partial cycle begins, then it is deemed to be unsuccessful . |

Ending the program prematurely

A reprocessing program ends automatically after the set drying duration has elapsed, see [Drying mode and duration](#) [▶ page 150].

You can end a reprocessing program prematurely, i.e. before the set temperature for the program end has been reached.

The following must be fulfilled or present:

- ✓ The **Disinfecting** partial cycle has finished.
- 1. Wait until the **Drying** partial cycle appears on the display.
- 2. Press **ABORT** and confirm with **YES**.
- 3. Press **OPEN DOOR** to unlock the door.
 - ↳ Humid air can escape from the washing chamber and dry the load with residual heat.

Cancelling a program

⚠ WARNING

Warning of contamination caused by cancelled program or malfunction

If a program is cancelled before the **Drying** partial cycle begins, then the load is deemed to be not disinfected.

- Wear suitable personal protective equipment (e.g. gloves).
- Reprocess the instruments again.

1. Press **ABORT** and confirm with **YES**.
2. Follow the instructions on the display.
3. Press **OPEN DOOR** to unlock the door.

↳ The program was not completed successfully.

Program result

Program successful

If a program has been completed successfully, an acoustic signal sounds and the status LED of the operating panel is lit green.

In addition to the program name, the program result is also displayed as **successful** and marked with ✓.

Program not successful

If a program was not finished successfully, the status LED of the operating panel is lit red.

In addition to the program name, the program result is also displayed as **not successful** and marked with ✗.

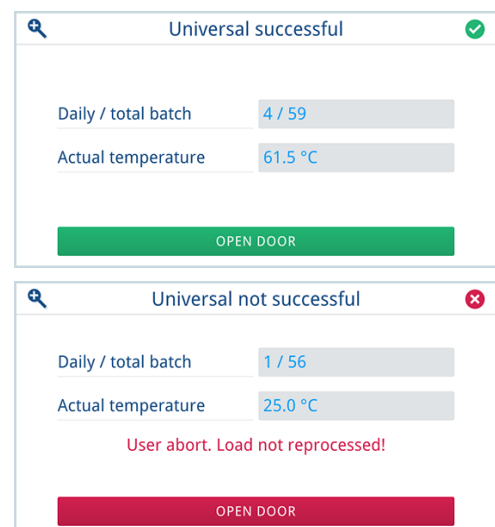

PLEASE NOTE: If the program is displayed as **not successful** or the status LED is not lit green, restart the reprocessing program.

In addition to the program result, the number of the daily batch and the total number of batches and the residual temperature are displayed. Press the magnifying glass on the left next to the program result to display other information on this program. This information helps you to assess the ▶[batch](#) for approval.

Confirming the program result

The program result is confirmed with the opening of the door and differs depending on the setting — door opening, manual or automatic.

Manual door opening

1. Press **OPEN DOOR** to confirm the displayed program result.
 2. If necessary, enter your user PIN for the authentication.
- The door is unlocked.

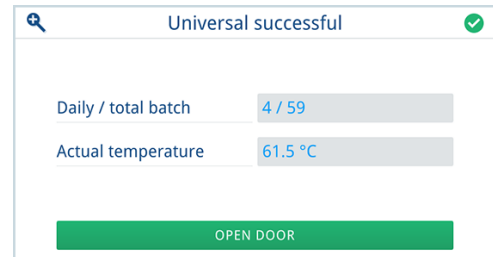

Automatic door opening

1. Wait until the door opens automatically.
2. Press **OK** to confirm the displayed program result.

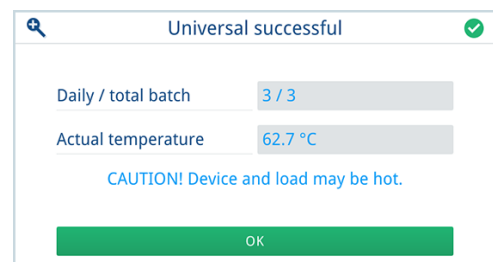

Removing the load and approving the batch

⚠ CAUTION

Warning of burns from hot instruments and surfaces

At the end of a program, instruments and the washing chamber can still be hot.

- Allow the device to cool before removing the instruments.
- Wear suitable protective gloves.

📌 PLEASE NOTE

Open the door immediately after the program has finished or activate automatic door opening to prevent the formation of condensation.

Do not leave any instruments in the washing chamber overnight.

According to [▶RKI](#) "Anforderungen an die Hygiene bei der Aufbereitung von Medizinprodukten" [Hygiene requirements for the reprocessing of medical devices], instrument reprocessing ends with the documented approval of the load. The approval process must be carried out by authorised and [▶competent personnel](#).

Note the following:

- The approval process takes place with the door open. During the process you can neither close the door nor is it locked.
- The scope of the approval process depends on the activated approval options (authentication, indicator assessment, batch approval), see [Authentication](#) [▶ page 156] and [Approval](#) [▶ page 156].
- If at least one approval option is activated, an acoustic signal sounds until the approval process is finished.

The approval process

The complete release process is described in the following, i.e. the indicator assessment and the batch approval are activated. In addition, authentication is activated.

PLEASE NOTE

If the authentication is skipped, the indicator assessment and batch approval are also skipped.

The indicator assessment and the batch approval are shown in the program log as "Skipped".

The approval process starts with confirmation of the program result.

The following must be fulfilled or present:

- ✓ The program result is successful, the status LED on the display is lit green and an acoustic signal sounds.
 - ✓ The program result has been confirmed.
1. Enter your user PIN for the authentication.
 2. Assess the indicator and press **SAVE**.



3. Remove the load while complying with all the hygiene and working safety regulations.
4. Check the load.
 - ➔ The load is completely cleaned.
 - ➔ The hollow-body instruments sit securely on the adapters.
5. Check the hollow-body instruments for potential blockages, at the latest prior to their next use.
6. Press **YES**, if the assessment criteria are met.
Press **NO**, if the assessment criteria are not met.



- ➔ The approval process is finished.
- ➔ The user ID and the result of the approval process are shown in the program log.
- ➔ The log is output automatically if activated.

11 Logging

Batch documentation

The batch documentation serves as proof of the successful conclusion of the program and represents an obligatory part of quality assurance. The device internal log memory saves such data as the program type, [▶batch](#) and process parameters of all the programs completed.

To obtain the batch documentation, you can output the internal log memory and transfer its data to various output media. This can be performed immediately at the end of every program or at a later point, such as at the end of the day.

Capacity of the internal log memory

The device is equipped with an internal log memory. All data of the programs run are stored in it automatically. The capacity of the internal log memory is sufficient for 100 logs. A message appears on the display if the internal log memory is full. Output the logs on at least one output medium. If you continue the program without program output, the oldest log is overwritten.

The number of unused log memory spaces can be found under **Device status > Batch documentation**.

1. Press **i** in the information area of the display.
2. Navigate in the **Device status** menu to **Batch documentation**.
3. Open the submenu.

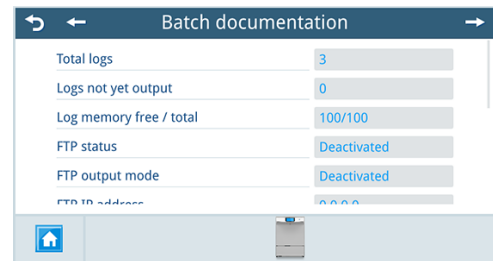

MELAG recommends outputting logs automatically, see [Outputting logs automatically](#) [▶ page 137].

Output media

The following output media are available for the log output.

| Icon | Name | Description |
|------|-----------|---|
| | MELAtrace | Logging with the help of the MELAtrace documentation software |
| | FTP | Logging on a FTP server |
| | USB*) | Logging on a USB stick connected to the device |

*) You can only connect one USB storage medium.

One output medium or several output media can be activated and configured for output of the logs, see [Log output](#) [▶ page 142].

NOTICE

Warning of data loss

Data loss, damage to the USB stick, the device and/or the software is possible if the USB stick is pulled out prematurely or is handled improperly.

- Never remove the USB stick during write and read access of the device.

Finding the logs

PLEASE NOTE

Do not rename the directories, as otherwise logs are stored not only in the renamed directory but also in the device directory generated automatically by the device.

Storage location

If the logs are output onto a USB stick the logs are stored in a different folder of the main directory.

The logs are output onto a computer via the network and using the MELAG ▶FTP server. You define the storage location on your computer in the FTP server program.

For output via ▶TCP and, e.g. MELAtrace, define the storage folder in the program.

Directory

After a log output there is a folder with the serial number of the device on all storage media (USB stick or computer). This folder contains other subfolders with the months of the log generation, e.g. 2024-11 for November 2024. This contains all logs generated by the device this month.

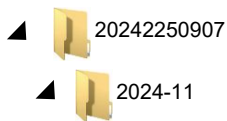

Displaying logs on the computer

The log files are generated in html format and can be displayed and printed on the computer with a web browser or in MELAtrace.

The program, malfunction and status protocols contain a legend entry for each line. The program logs contain graphic data and can be displayed as graphic logs in MELAtrace.

Logs menu

Different log types can be displayed and output via the **Logs** menu.

You can output logs subsequently and independently of the time of a program end.



| Log type | Description |
|-----------------|--|
| Program log | Log of a program |
| Malfunction log | Log with malfunctions that occurred outside a program run |
| Status log | Summary of all important settings and system statuses |
| System log | List of all the malfunctions and changes to the system in order of time (log book) The system log is output in English. |

List of logs

A log list of all logs of the internal log memory is created continuously for program logs and malfunction logs. You can read and manually output individual logs.

With the help of the scroll bar, you can navigate up and down within the log list. You can sort the list by pressing the column headings.

Log list layout

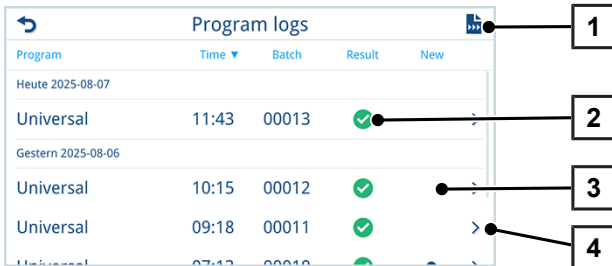

- 1 Button **Log output options**
- 2 Program result:
✔ successful | ✘ not successful
- 3 Output status:
 Dot = log not output
- 4 Open log preview

Outputting logs manually

Logs are output manually via the **Log output options** submenu. You can output individual or multiple logs of the internal log memory.

Outputting program logs or malfunction logs

You can either output one log each or multiple logs simultaneously via the log list of the program logs and malfunction logs.

Outputting multiple logs

1. In the **Logs** menu, select the log type **Program logs** or **Malfunction logs**.

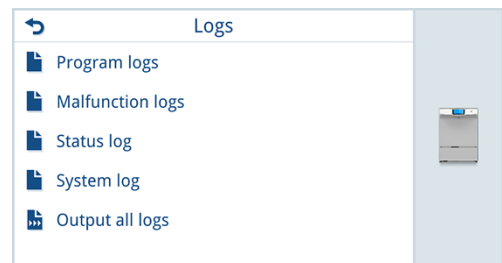

➡ The log list of the selected log type is displayed.

2. Press in the log list.

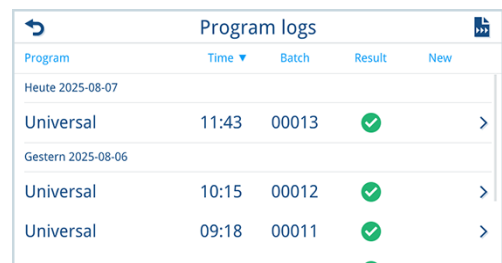

➡ The **Log output options** submenu is displayed.

If you open the **Log output options** submenu from a log list, you can then select the number of logs to be output via the output status.

| Output status | Description |
|---------------|--|
| Not output | Output all logs of the log list not yet outputted |
| Last | Output the last successfully run program from the log list |
| All | Output all logs in the log list |

3. Select the output status.
4. Select at least one output medium.
5. Press **OUTPUT LOGS**.

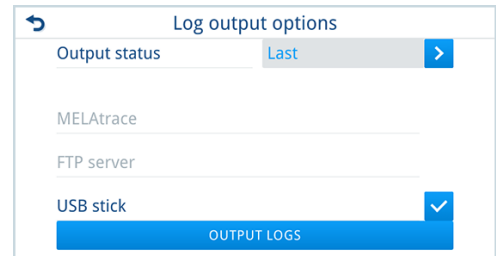

PLEASE NOTE

A greyed-out output medium is not available for log output. If you want to use a greyed-out output medium, activate this medium in the settings, see [Log output](#) [▶ page 142].

Outputting a log in the log list

1. In the **Logs** menu, select the log type **Program logs** or **Malfunction logs**.

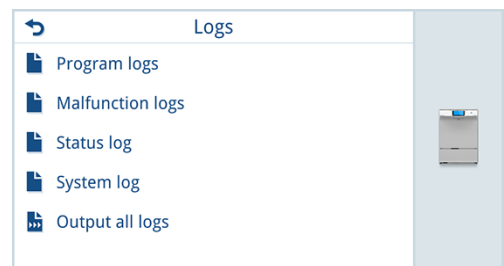

2. In the log list, press > of the required program.

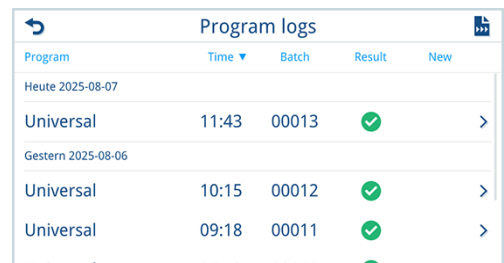

↪ The log preview is displayed.

3. Use the scroll bar to navigate through the log preview and press **OUTPUT LOG** at the end of the log preview.



Outputting status log or system log

1. Select the **Logs** menu, the **Status log** or **System log** log type.



↳ The log preview of the selected log type is displayed.

2. Use the scroll bar to navigate through the log preview and press **OUTPUT LOG** at the end.

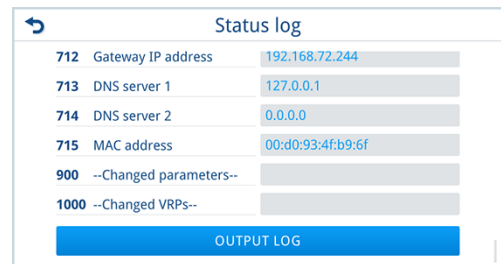

Outputting all logs

- ▶ In the **Logs** menu, select the **Output all logs** function.

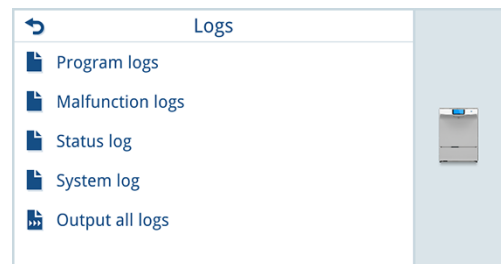

Outputting logs automatically

The following conditions must be met for automatic log output after the end of a program.

- In the **Settings > Log output** menu, at least one output medium is set to **Automatic**, see [Log output](#) [▶ page 142].
- The activated output medium (e.g. USB stick) is connected to the device.

At the end of the program run, the log is output to the selected output medium. At the same time, this log is stored in the internal log memory and is marked there as outputted.

If several output media are activated, all activated output media must be connected to the device. Otherwise the logs are stored in the internal log memory and are deemed to be not outputted.

12 Function checks

Automatic and manual function check

Automatic

The device components are monitored and checked automatically for their functionality and interplay. Should the parameter thresholds be exceeded, the device will issue warning messages or malfunction messages. If necessary, it will abort a program with the relevant notification. The device will also display messages when a program has been completed.

Manual

You can follow the program run on the display and use the log recorded to check the success of a program. Further information is provided in chapter [Logging](#) [▶ page 133].

Measuring conductivity

You can access the water quality of the ▶DI water on the switched-on device's display at any time.

1. Open the **Service programs** menu.
2. Select **Measuring conductivity** and press **Start**.

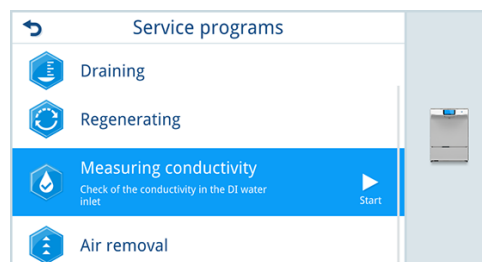

13 General settings

General settings can be changed by any user.

Menu settings

Submenus for general device settings are available in the **Settings** menu.

It is not necessary to enter a user PIN.

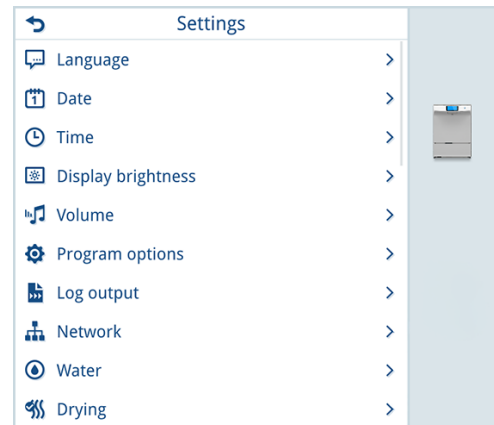

Please note the following:

- The door of the device must be closed to make a setting.
- The setting is finished as soon as a change is confirmed or saved. The view switches back to the higher-level menu.
- It is not necessary to restart the device. Settings are adopted immediately.

Discarding/not discarding settings

↩ If you exit the submenu without saving the setting is discarded. The following confirmation prompt appears.

- ▶ Press **YES**, if you want to discard the setting.
 - ↳ The view switches to the higher-level menu.
 - ↳ The parameters remain unchanged.
- ▶ Press **NO** if you do not want to discard the setting.
 - ↳ The view switches back to the submenu. Settings can be made.

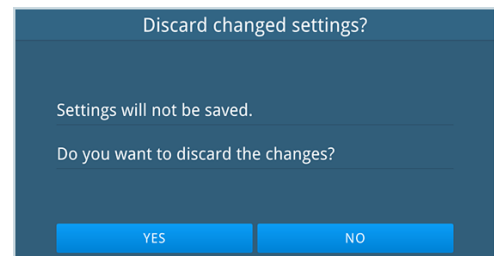

Language

Not all languages are directly available in the menu. These languages can only be activated with the help of an activation code.

Setting a language without activation code

The following must be fulfilled or present:

- ✓ The **Settings > Language** menu is open.
- 1. Use the adjustment wheel to select the language.
 - ↳ The selected language is highlighted with white lettering.
- 2. Press **CONFIRM**.
 - ↳ The selected language is changed immediately.
 - ↳ The selected language is used on the display and in logs.

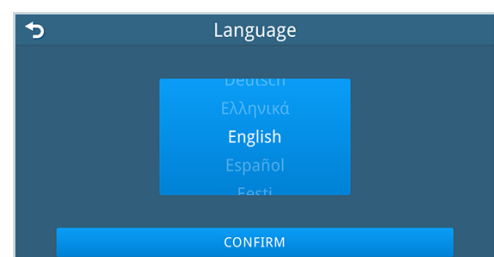

Setting a language with activation code

You can get the activation code from your authorised customer service.

The following must be fulfilled or present:

- ✓ The activation code is available.
- ✓ The **Settings > Language** menu is open.
- 1. Use the adjustment wheel to select the language.
 - ↳ The selected language is highlighted with white lettering.
- 2. Press **UNLOCK**.
- 3. Enter the activation code and confirm it with **OK**.
- 4. Press **CONFIRM**.
 - ↳ The selected language is changed immediately.
 - ↳ The selected language is used on the display and in logs.

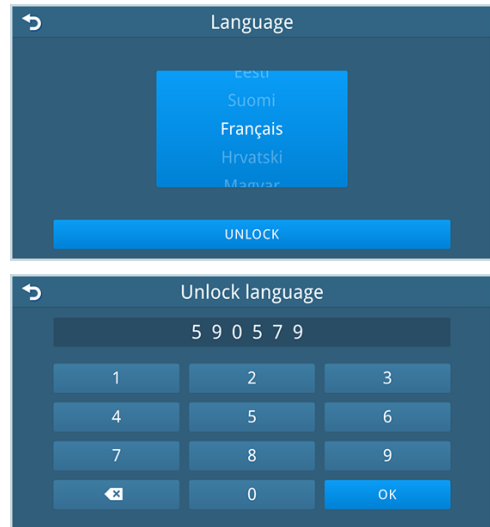

Date and time

Date and time of the device must be correctly set for proper batch documentation. Any daylight saving clock change in the autumn and spring does not take plate automatically.

Date

The following must be fulfilled or present:

- ✓ The **Settings > Date** menu is open.
- 1. Use the adjustment wheels to set the date (year | month | day).
- 2. Press **SAVE**.

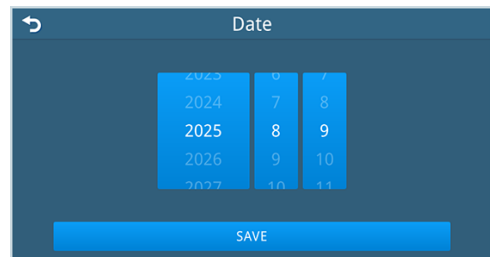

Time

The following must be fulfilled or present:

- ✓ The **Settings > Time** menu is open.
- 1. Use the adjustment wheels to set the time (hour | minutes).
- 2. Press **SAVE**.

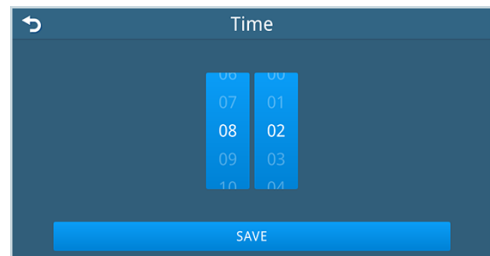

Display brightness

The following must be fulfilled or present:

- ✓ The **Settings > Display brightness** menu is open.
- 1. Move the controller (pos. b) to the left or right. Alternatively, press plus or minus.
 Minus = reduce display brightness
 Plus = increase display brightness
 - ➔ The colour bar (pos. a) gives an impression of the colour contrast.
- 2. Press **SAVE**.

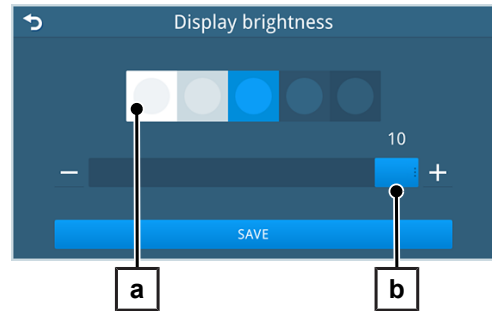

Volume

The following must be fulfilled or present:

- ✓ The **Settings > Volume** menu is open.
- 1. Move the controller (pos. a) to the left or right. Alternatively, press plus or minus.
 Minus = reduce volume (0 = sound off)
 Plus = increase volume
- 2. Press **SAVE**.

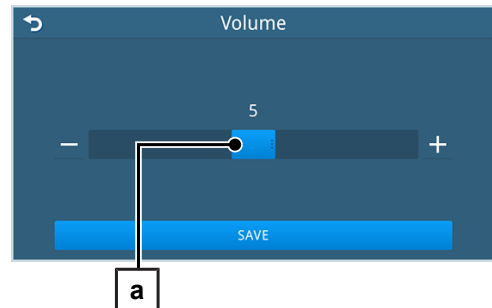

Program options

In the **Program options** submenu you can select the metering pumps of the process agents, which are to be de-aerated during the **Air removal** service program. This setting can be adjusted before the program start if necessary.

By default, all metering pumps are selected for de-aeration.

PLEASE NOTE: The **Air removal** service program cannot be started until at least one metering pump has been selected.

Select the process agents metering pumps for de-aeration

The following example describes the deselection of the rinse aid metering pump.

The following must be fulfilled or present:

- ✓ The **Settings > Program options** menu is open.
- 1. In the **Rinse aid** row, press .

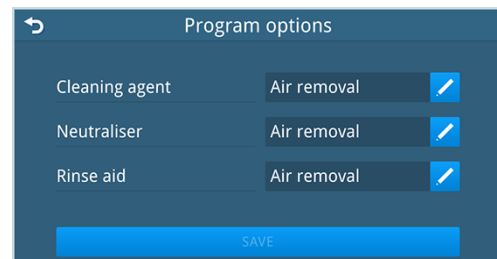

2. Press **Do not remove air** and confirm with **OK**.

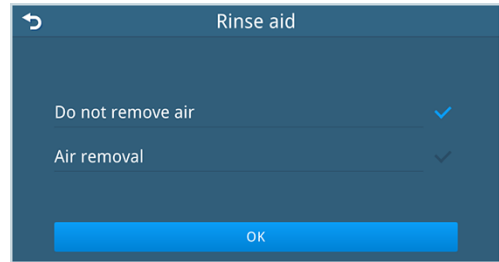

3. Press **SAVE**.

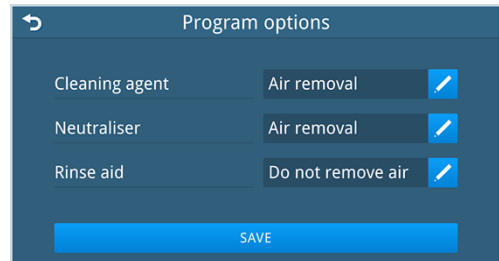

➔ After starting the **Air removal** service program, the metering line of the cleaning agent and the neutraliser are de-aerated one after the other. The metering line of the rinse aid is not de-aerated.

Log output

In the **Log output** submenu, you can select the output media for the logging and the type of logging.

Output media: MELAtrace, FTP server, USB stick



| Type of logging | Description |
|------------------|--|
| Manual | The log is output manually on the selected output medium or the selected output media. |
| Automatic | The log is output automatically, after the end of the program, on the selected output medium or the selected output media. |

MELAtrace

The log output to MELAtrace is deactivated by default.

Activating log output

The following must be fulfilled or present:

- ✓ The **Settings > Log output > MELAtrace** menu is open.

1. In the **Log output** row, press .

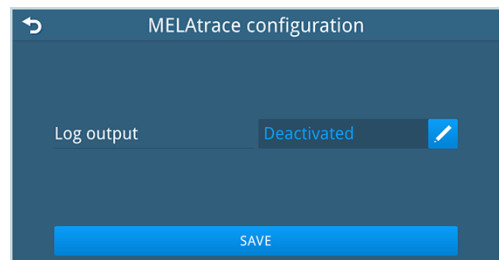

2. Select the type of logging (**Manual** or **Automatic**) and confirm with **OK**.

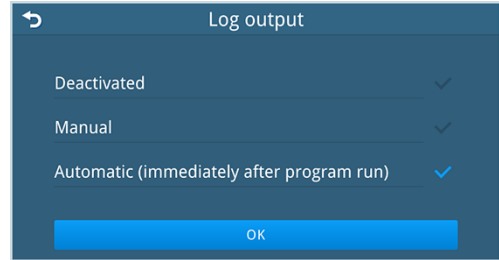

3. Press **SAVE**.

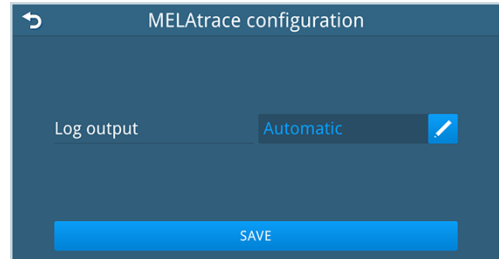

Deactivating log output

1. In the **Log output** row, press .

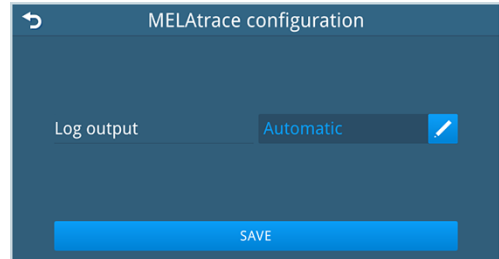

2. Select **Deactivated** and confirm with **OK**.

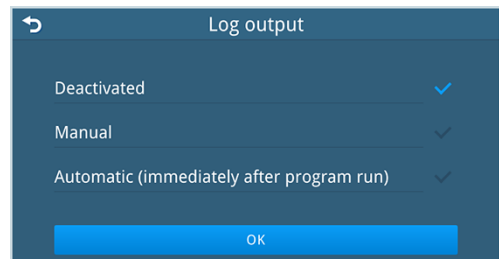

3. Press **SAVE**.

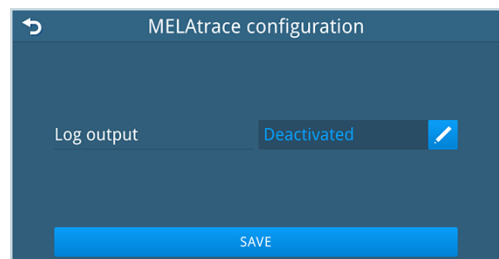

 Log output is not possible, even if MELAttrace is available.

FTP server

Log output to the FTP server is deactivated by default.

The data shown in the following are exemplary for setting up the FTP server.

Setting up the FTP server at the device

The following must be fulfilled or present:

- ✓ The **Settings > Log output > FTP** menu is open.

1. In the **Log output** row, press .

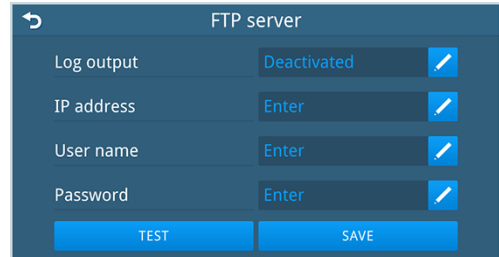

2. Select the type of logging (**Manual** or **Automatic**) and confirm with **OK**.

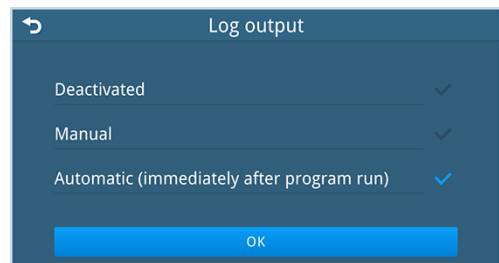

3. In the **IP address** row, press .

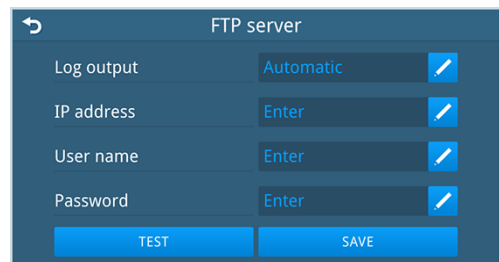

4. Enter the IP address of the FTP server and confirm with **OK**.



5. In the **User name** row, press .

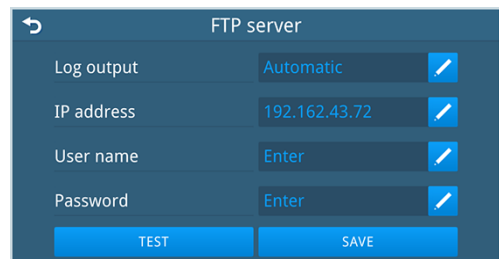

6. Enter the user name of the FTP server and confirm with **OK**.

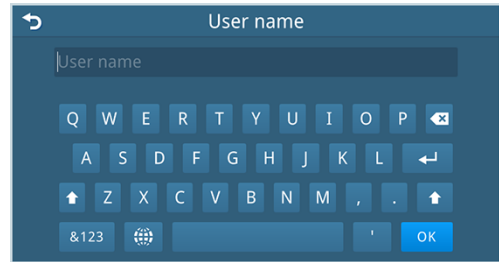

7. In the **Password** row, press .

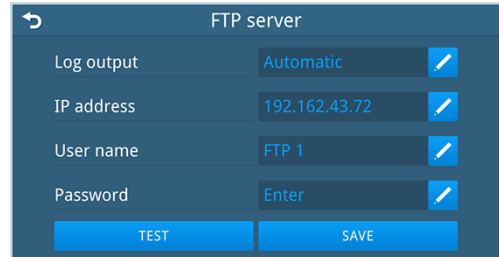

8. Enter the password of the FTP server and confirm with **OK**.

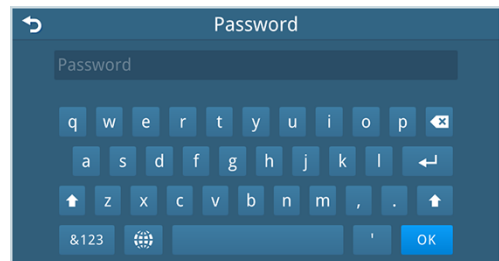

- 9. Press **TEST** to check the connection to the FTP server.
- 10. Press **SAVE** if the test is successful.

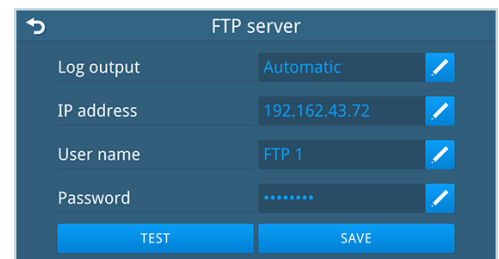

▶ If the test is not successful, check the inputs and test again.

Deactivating log output

1. In the **Log output** row, press .

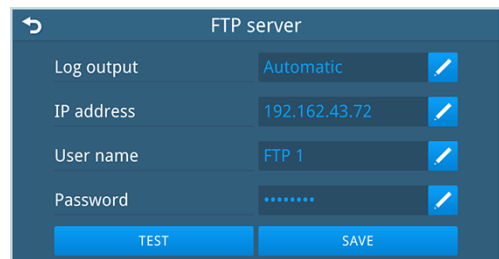

2. Select **Deactivated** and confirm with **OK**.

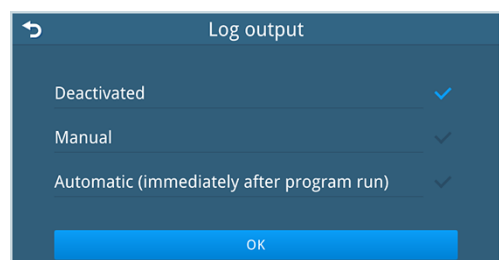

3. Press **SAVE**.

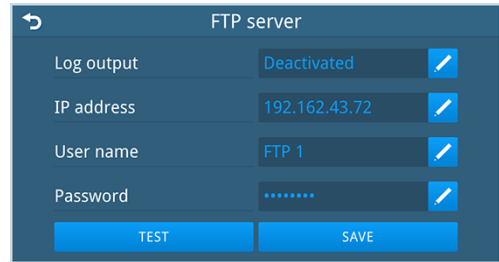

→ Log output is not possible, even if an FTP server is available.

USB stick

Log output onto a USB stick is deactivated by default.

Activating log output

The following must be fulfilled or present:

- ✓ The **Settings > Log output > USB** menu is open.

1. In the **Log output** row, press .

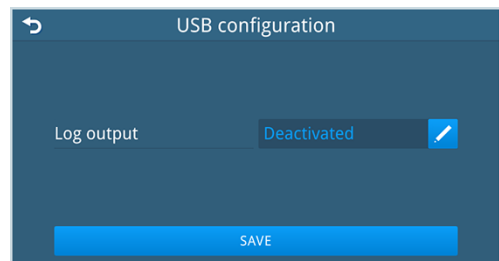

2. Select the type of logging (**Manual** or **Automatic**) and confirm with **OK**.

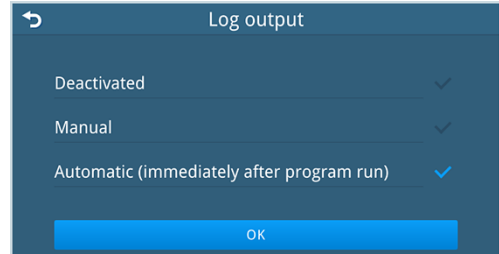

3. Press **SAVE**.

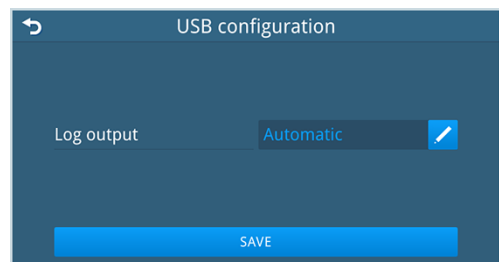

Deactivating log output

1. In the **Log output** row, press .

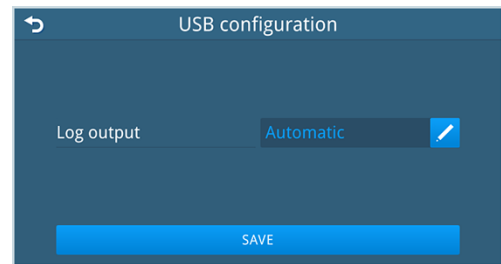

2. Select **Deactivated** and confirm with **OK**.

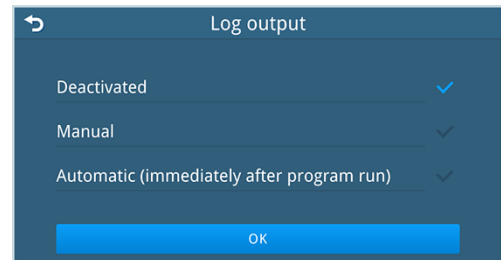

3. Press **SAVE**.

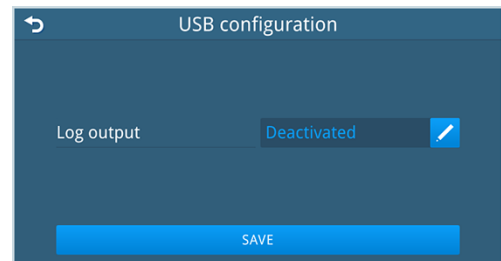

➔ Log output is not possible, even if an USB stick is connected to the device.

Network

NOTICE

Warning of data loss

Deeper knowledge of network technology is necessary for the setting up of the practice network. Errors when handling IP addresses can result in malfunctions and data loss in your practice network.

- Only allow the system administrator of the practice network to set the IP addresses.

In the **Network** submenu you can select automatic configuration via DHCP or enter the data manually. With automatic configuration, all data are added automatically if the device in the practice network is integrated with a DHCP server. If there is no DHCP server, the fields remain empty.

The data shown in the following are given as an example of a network setting.

The following must be fulfilled or present:

- ✓ The **Settings > Network** menu is open.
1. Select **Manual** or **Automatic (DHCP)** for the configuration.
 2. For the manual configuration, press  to enter all network data.
 3. Press **SAVE**.

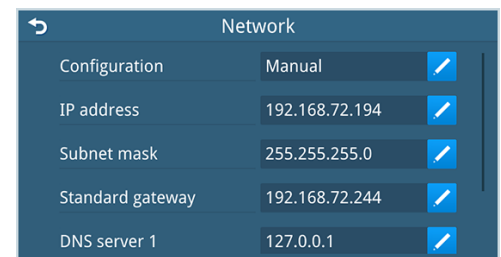

Water

In the **Water** submenu, enter whether **DI water** is used for the reprocessing and the value of the determined water hardness of the cold water.

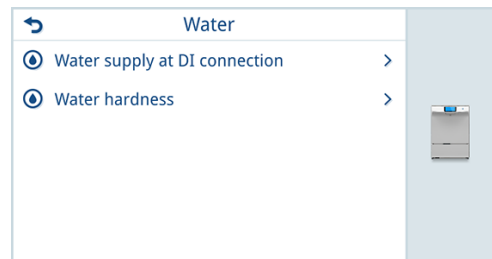

PLEASE NOTE This setting is made by the **authorised technician** during the commissioning of the device.

DI connection water supply

If de-ionised water (**DI water**) is not used for the **reprocessing**, this must be entered in the menu.

Water supply with DI water is selected by default.

PLEASE NOTE In ophthalmology, DI water is mandatory for reprocessing. If the supply with DI water is not selected in the menu, the **OphthAlmo** program cannot be started.

The following must be fulfilled or present:

- ✓ The **Settings > Water > Water supply at DI connection** menu is open.
- 1. Read the notice on DI water.
- 2. Press **OK**.

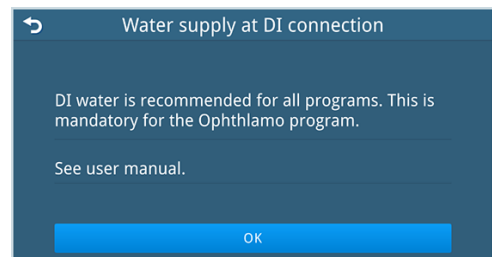

Water supply with DI water

The following must be fulfilled or present:

- ✓ The inlet hose for the DI water is connected to a water treatment unit.
 - ✓ The inlet hose for the cold water is connected to the building's cold water inlet.
 - 1. Select **DI water**.
 - 2. Press **OK**.
- ➔ DI water is supplied via the DI water connection of the device.

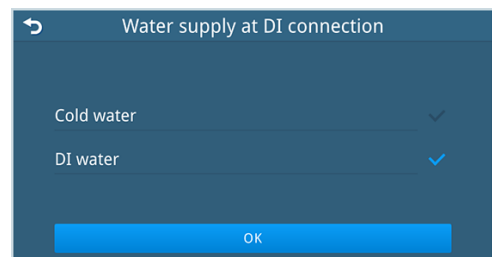

Water supply without DI water

The following must be fulfilled or present:

- ✓ Both water inlet hoses are connected to the building’s cold water inlet.
 - 1. Select **Cold water** if no DI water is supplied.
 - 2. Press **SAVE**.
- ➔ Cold water is supplied via the DI water connection of the device.

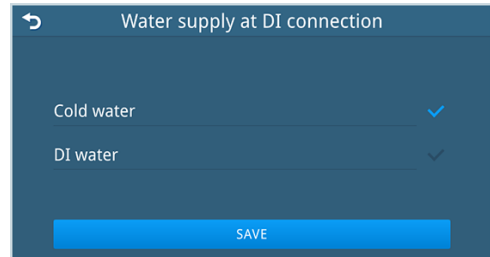

PLEASE NOTE

In the menu **Process relevant parameters**, the **Disinfecting** partial cycle is set to DI water (= ON) by default for all reprocessing programs.

- If cold water is selected under water supply in the settings, have the process-relevant parameters adjusted by an **authorised technician**.

Water hardness

During commissioning of the device, the **authorised technician** determines the water hardness and enters the value in the menu.

The following must be fulfilled or present:

- ✓ The **Settings > Water > Water hardness** menu is open.
- 1. Note the notice on setting the water hardness.
- 2. Press **OK**.
- 3. Use the adjustment wheel to set the determined water hardness.
- 4. Press **SAVE**.

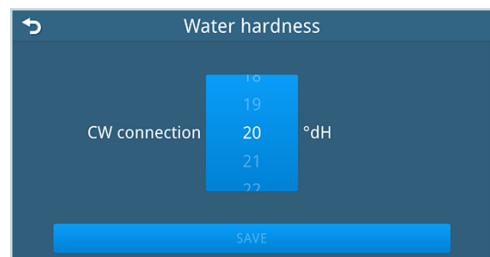
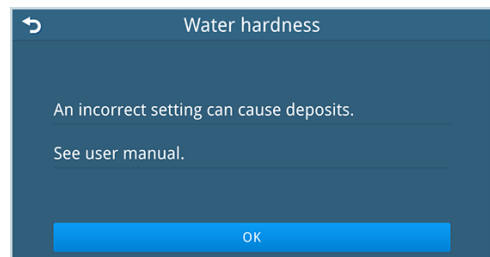

Drying

In the **Drying** submenu, you can set the drying mode and the duration of the drying mode for all reprocessing programs.

You can also set the door-opening mode – automatic or manual.

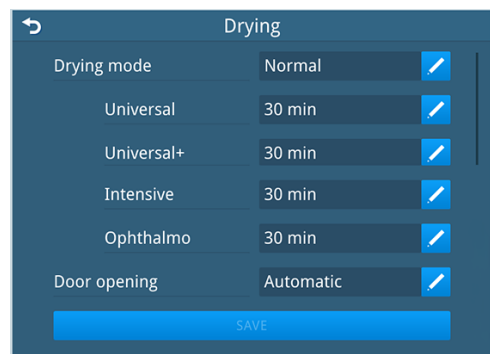

Drying mode and duration

The drying mode determines the drying duration in minutes. The duration can be set individually for each program. In the **Power** drying mode, a higher air flow is generated than in **Normal** mode, reducing the drying time.

Factory setting

- Drying mode **Power**: 15 min
- Drying mode **Normal**: 30 min

Setting the drying mode

The following must be fulfilled or present:

- ✓ The **Settings > Drying** menu is open.

1. In the **Drying mode** row, press .



2. Select the mode **Normal** or **Power** and press **OK**.

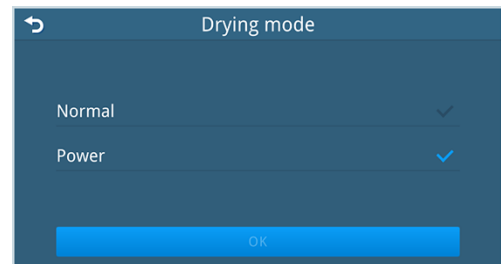

3. Press **SAVE** or set the duration of the selected drying mode.



Setting the duration

1. In the row of the respective program (e.g. **Universal**), press .

2. Select the drying duration using the adjustment wheel and press **OK**.

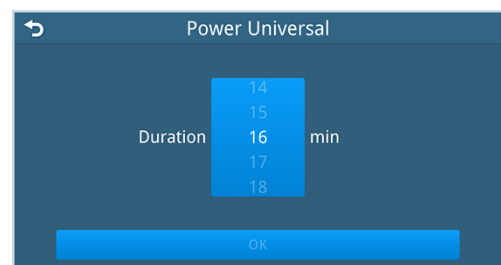

3. Press **SAVE**.

Door opening

| | Description |
|-----------|---|
| Automatic | After a successfully run program, a signal sounds and the door opens after approx. 2 s or after the time shown on the display. This function is activated by default. |
| Manual | After a completed program, an acoustic signal sounds and the door remains closed. The door is opened manually using the OPEN DOOR button. |

The following must be fulfilled or present:

- ✓ The **Settings > Drying** menu is open.

1. In the **Door opening** row, press .

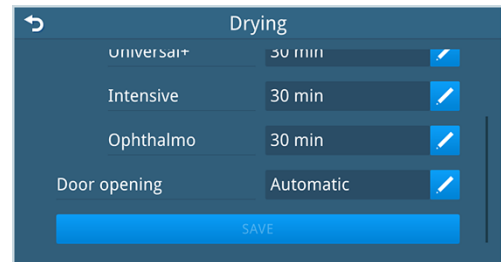

2. Select **Automatic** or **Manual** and press **OK**.

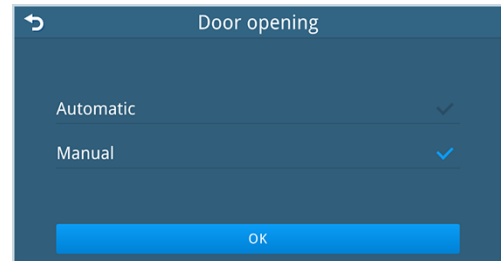

3. Press **SAVE**.

14 Administrative settings

In the **Administration** menu you can only make settings as the logged in administrator or service technician.

When the device is delivered, the admin PIN is set to 1000 by default. MELAG recommends changing the Admin PIN when commissioning the device, see [Changing the administrator PIN](#) [▶ page 156].



Please note the following:

- The door of the device must be closed to make a setting.
- The setting is finished as soon as a change is confirmed or saved. The view switches back to the higher-level menu.
- It is not necessary to restart the device. Settings are adopted immediately.

Discarding/not discarding settings

↩ If you exit the submenu without saving the setting is discarded. The following confirmation prompt appears.

- ▶ Press **YES**, if you want to discard the setting.
 - ➔ The view switches to the higher-level menu.
 - ➔ The parameters remain unchanged.
- ▶ Press **NO** if you do not want to discard the setting.
 - ➔ The view switches back to the submenu. Settings can be made.

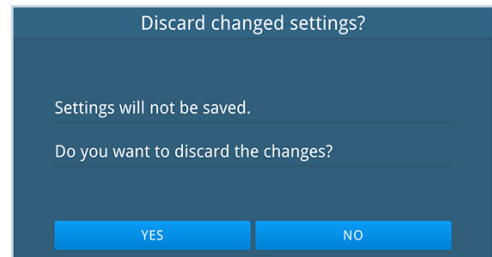

Logging in/out as the administrator

Login

1. Press  in the information area of the display.
2. Select the **Administrator** user role.

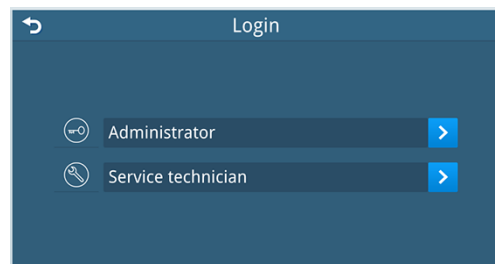

3. Enter the 4-digit admin PIN.



→ The view switches to the main menu.

→ The user role button switches to

Log out

1. Press
2. Press LOGOUT.

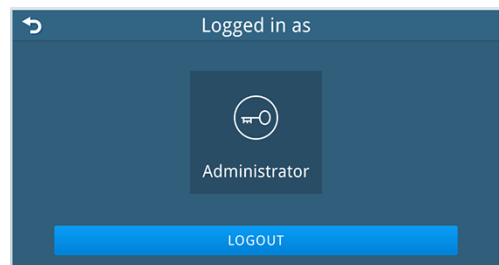

→ The view switches to the main menu.

→ The User role button switches to

Users

The **Users** submenu is used for user administration. User data such as ID, name and PIN can be created, edited or deleted.

These user data are needed for the possibly required authentication and for traceability of the approval process after a program run.

Creating users

The following must be fulfilled or present:

- ✓ The **Administration > Users** menu is open.

1. Press

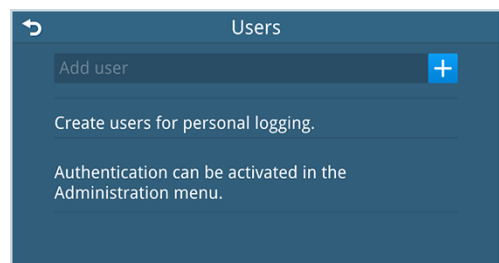

2. Enter a user name and confirm with **OK**.

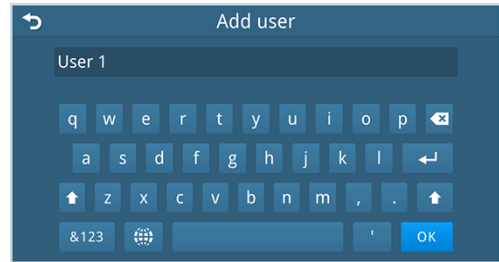

3. Enter a not yet assigned 4-digit user PIN and confirm with **OK**.



4. Check the data. Press  if you want to change data.
PLEASE NOTE: The user ID is issued consecutively automatically and can be changed if needed.



5. Press **SAVE**.

Editing a user

Editing the user PIN is described in the following. The user ID and the user name are edited in the same way.

The following must be fulfilled or present:

- ✓ The **Administration > Users** menu is open.

1. Press  of the user whose data are to be edited.

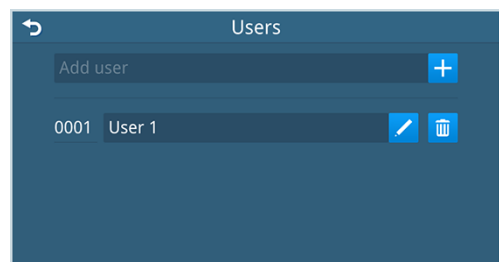

2. In the **PIN** row, press .



- 3. Enter a not yet issued 4-digit PIN and confirm with **OK**. **PLEASE NOTE:** The PIN 1000 is reserved for the administrator and cannot be assigned to another user ID. This also applies if the admin PIN has been changed.

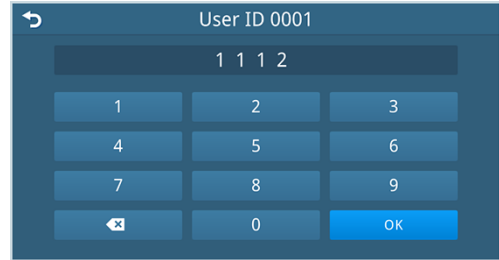

- 4. Check the data. Press  if you want to change data.



- 5. Press **SAVE**.

Delete user

The following must be fulfilled or present:

- ✓ The **Administration > Users** menu is open.

- 1. Press  of the user whose data are to be deleted.

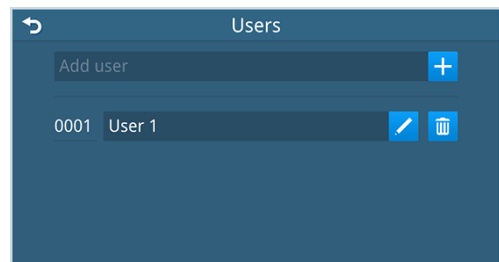

- 2. Press **DELETE**.

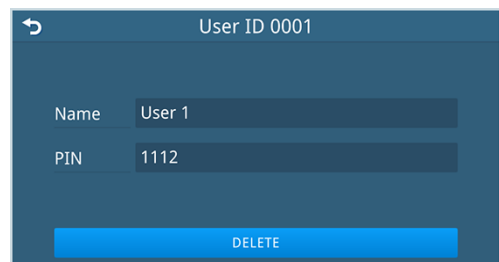

Authentication

Authentication is used for personalised device use at the program start and/or program end. If authentication is activated, you are automatically prompted to enter your user PIN before a program start and/or after a program end. The user ID is shown in the log for **User program start** and/or **User program end**.

Authentication is deactivated by default, i.e. no option is selected in the submenu.

The following must be fulfilled or present:

- ✓ The **Administration > Authentication** menu is open.
- 1. Select the required authentication at the program start and/or program end.
- 2. Press **SAVE**.

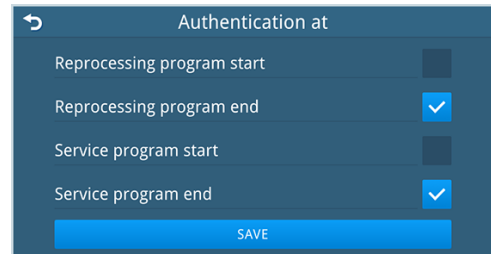

Approval

The scope of the approval process following a successfully run program depends on the settings. The **Batch approval** and **Indicator assessment** approval options are deactivated by default.

At least one approval option must be selected for an activated approval process. If an approval option is not selected, this step in the approval process is skipped automatically.

The following must be fulfilled or present:

- ✓ The **Administration > Approval** menu is open.
- 1. Select the required approval option(s).
- 2. Press **SAVE**.

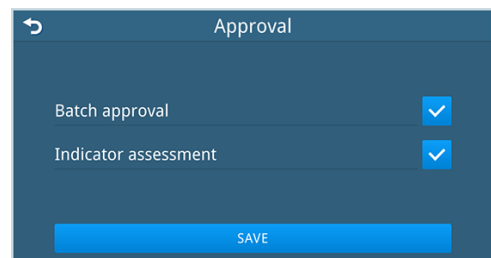

Changing the administrator PIN

PLEASE NOTE

If the changed administrator PIN is lost, contact an [authorised technician](#).

The following must be fulfilled or present:

- ✓ The **Administration > Change administrator PIN** menu is open.
- 1. Enter a not yet issued 4-digit PIN.

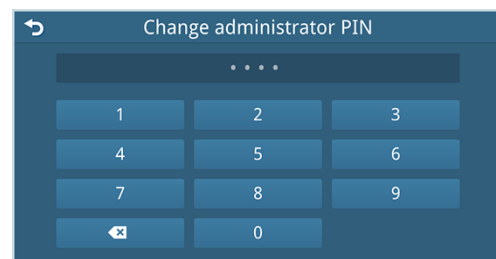

2. Press **SAVE**.

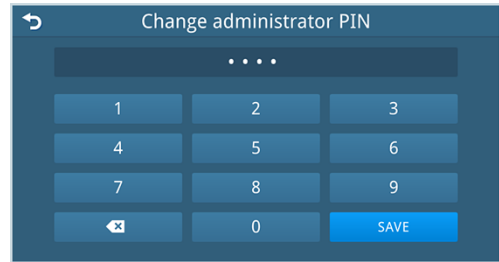

Favorites

For the Favorites menu, quick access to the reprocessing program can be set in position 1. All other functions cannot be changed.

The following must be fulfilled or present:

- ✓ The **Administration > Favorites** menu is open.

1. In the **Position 1** row, press .

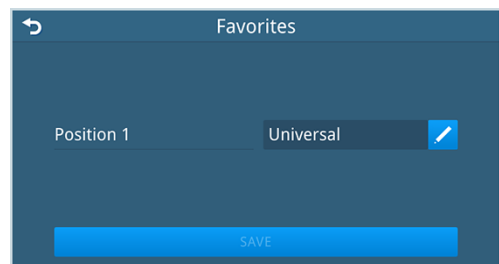

2. Select the reprocessing program (e.g. Ophthalmology) and confirm with **OK**.



3. Press **SAVE**.

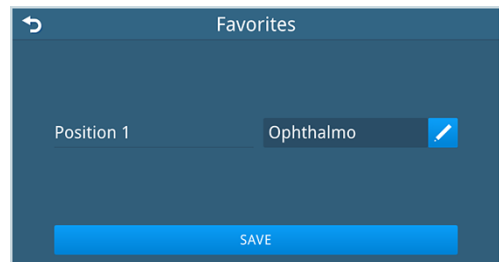

In the Favorites menu, the icon of the selected reprocessing program is displayed in the first position.



Software update

Downloading the current update file

The current file for the software update can be found in the Download centre of the MELAG website (Service > Download centre > MELAtherm 20 > Device software).

1. Download the current update file.
2. Save the current update file on a USB stick.

Carrying out the software update

PLEASE NOTE

During a software update, all logs of the internal log memory that have not yet been outputted are deleted.

- Before a software update, output the logs onto an output medium.

The following must be fulfilled or present:

- ✓ All logs of the internal log memory are output, see [Logging](#) [▶ page 133].
- ✓ The USB stick with the current update file is available.
- ✓ The **Administration > Software update** menu is open.

1. Insert the USB stick with the current update file into the device's USB port and press **NEXT**.

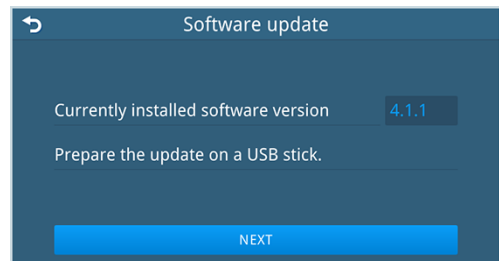

↳ During the loading process your are guided through the menu.

2. Press **YES** to start the update.

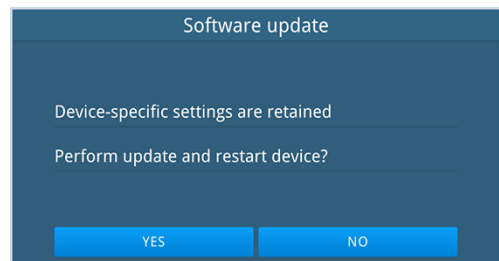

↳ During the software update, the device independently performs one or more restarts.

3. Wait until the start screen appears on the display.
4. In the download centre of the MELAG website, check whether a current user manual is available.

15 Maintenance

▲ WARNING

Warning of contamination

All maintenance work, especially that carried out in the washing chamber may only be carried out after a successfully completed reprocessing program.

- Wear suitable personal protective equipment (e.g. gloves).

Maintenance intervals

Device

| Interval | Measure | Device component |
|---|---|---|
| daily | Check for soiling, deposits or damage | Flat sieve, fine sieve, rinse arms, door gasket |
| monthly | Check for soiling, deposits or damage | Plastic parts, connectors in the washing chamber, sealing bushes, air filter of the E-Box, central filter, MediaGuard Box |
| As required | Check for contamination and deposits | Operating panel, front of the device, washing chamber, pump sump |
| as required (insufficient rinse pressure) | Cleaning | Central filter |
| as required (level of blockage exceeded) | Replacement | HEPA filter |
| after 24 months or 1000 cycles | Maintenance by ▶ authorised technicians | according to maintenance instructions |

Components for reprocessing

| Interval | Measure | Component |
|--|--|---|
| Before every reprocessing | Check for tight fit | Lower basket incl. injector rail module, adapter, hoses, connections |
| | Check for contamination, deposits and damage | all components |
| | Check for patency/blockage | Nozzles and adapters of the injector rail module |
| After each reprocessing | Check for dirt residues | all components |
| | Check for tight fit | Lower basket incl. injector rail module, adapter, hoses, connections |
| Every 2 weeks or after 20 cycles at the latest | Replacement and proper disposal | Ceramic filter disc, see Ceramic filter disc ▶ page 109 |
| | Reprocessing (in the ultrasonic bath) | Metal filter disc, see Metal filter disc ▶ page 110 |
| after reprocessing 20 times | Replacement and proper disposal | Metal filter disc, see Metal filter disc ▶ page 110 |
| As required | Replacement and proper disposal | see Spare parts ▶ page 183 *) |

*) Only use original spare parts from MELAG.

Regular checking and cleaning

NOTICE

Warning of material damage from incorrect cleaning

Incorrect cleaning can damage the surfaces and sealing faces. Scratched or damaged surfaces and leaking sealing surfaces can cause dirt deposits and corrosion in the washing chamber.

- Follow the instructions on cleaning the device components concerned.

Check in the washing chamber

The washing chamber must be cold and empty for the following checks.

Connectors

1. Clean the external sealing surface of the connectors monthly with a damp, lint-free cloth.
2. Check whether the connectors can be pressed in easily and move back to the starting position.

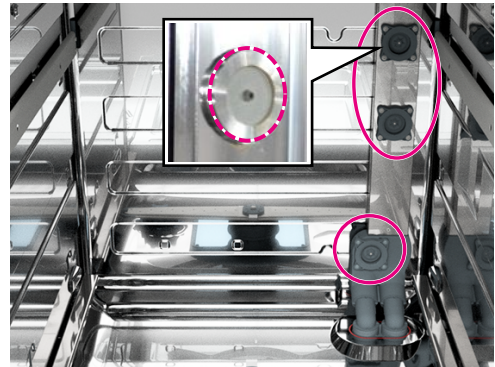

Rinse arms

Over time, dirt particles can clog the nozzles of the rinse arms. Check all rinse arms regularly.

1. Check whether the flat sieve and fine sieve are inserted correctly so that any dirt particles present or fixing parts of the rinse arms do not get into the pump sump.
2. Press the quick-release fastener of the respective rinse arm and remove the rinse arm.

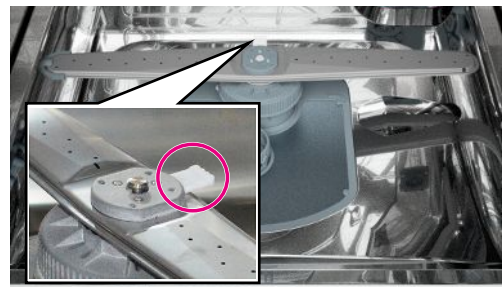

3. If necessary, rinse the nozzles under running water. Clean blocked nozzles with a thin pointed object.

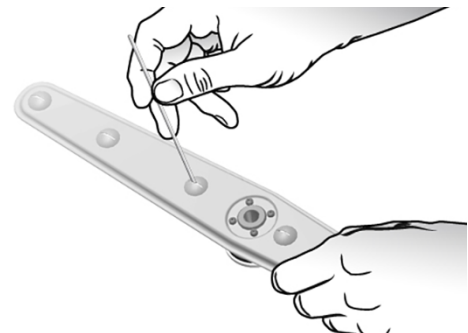

4. Check the magnet holder on all three rinse arms for tight fit.

5. Press the quick-release fastener and re-insert the rinse arm.
PLEASE NOTE: The position (top, middle, bottom) of the rinse arms in the washing chamber is defined. They can only be re-inserted in the correct position.
6. After inserting the rinse arms, check them for free and easy movement.

Central filter

Clean the central filter monthly or if the required rinse pressure is not reached despite correct loading.

1. Press the quick-release fastener (pos. a) of the lower rinse arm (pos. b) and remove the rinse arm.

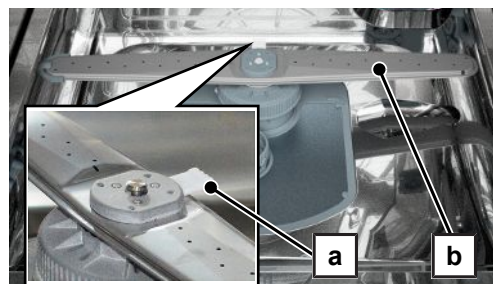

2. Turn the central filter including lid (pos. c) anti-clockwise and remove the filter from above.

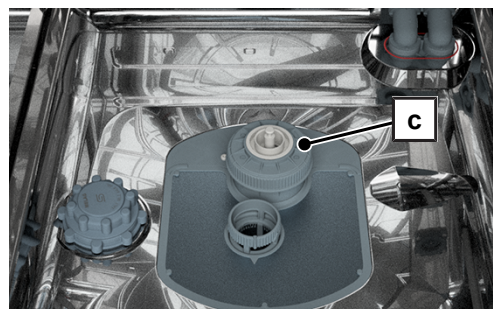

3. Clean the central filter under running water. If necessary, use a soft brush to loosen the dirt in the filter.
4. Insert the cleaned central filter including lid (pos. c) into the pump sump (pos. d). Tightly turn the central filter including lid (pos. c) clockwise.

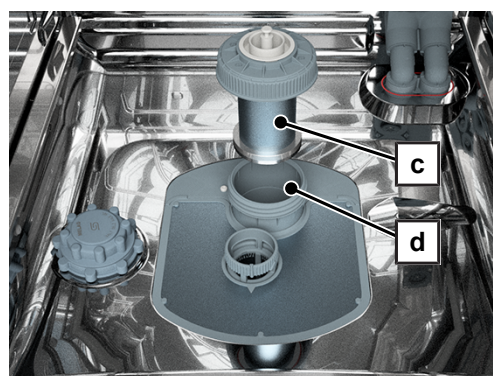

5. Press the quick-release fastener and re-insert the lower rinse arm.
6. After inserting the lower rinse arm, check it for free and easy movement.

Flat sieve and fine sieve

NOTICE

Warning of malfunction

Residues can get into the rinse cycle and impair the function of the device if the flat sieve and the fine sieve are missing or are not inserted correctly.

- Make sure that the flat sieve and the fine sieve are inserted before the program starts.

The sieves are designed to hold back dirt particles or residue e.g. from the instruments. They can become blocked over time.

1. Check the flat sieve (pos. a) and the fine sieve (pos. b) for soiling and fallen in small parts weekly.
2. Remove any small parts that have fallen in.
3. Turn the fine sieve (pos. b) anti-clockwise until it stops and remove it from above.
4. Remove the flat sieve (pos. a).
5. Check the two sieves for contamination.
6. **PLEASE NOTE:** Do not use washing-up liquid. Rinse soiled sieves und running water. Remove any deposits with a soft brush.
7. Insert the flat sieve.
8. Insert the fine sieve and turn the sieve clockwise until it stops. **PLEASE NOTE:** The flat sieve is fixed by the correctly inserted fine sieve.

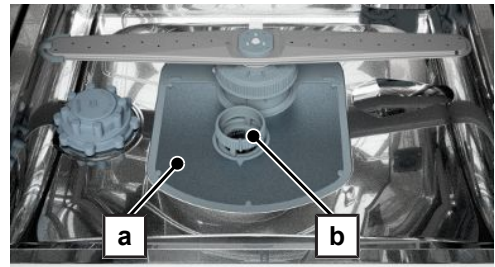

Checking the door gasket

1. Check the door gasket weekly for contamination, deposits and damage.
2. If necessary, clean the door gasket with a moist, lint-free cloth and commercially available neutral liquid cleaning agent.

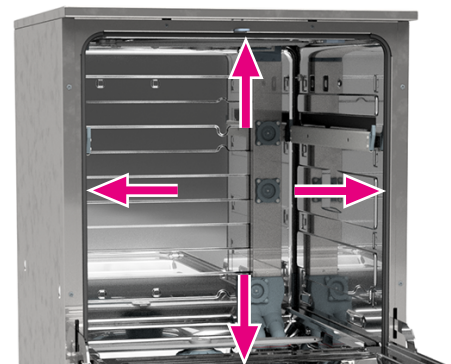

Checking the sealing bushes

The following components are equipped with a sealing bush:

- Upper basket (pos. b)
- Injector rail module (pos. a, if present)
- MELAtherm 20 DIN sieve trolley (if present)

1. Remove the components from the washing chamber.
2. Check the sealing bushes monthly for contamination, deposits and damage.
3. In case of damage, please contact an authorised technician.
4. Clean the sealing bushes with a damp, lint-free cloth.

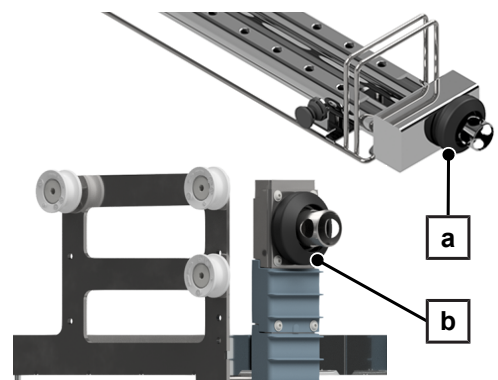

Checking the air filter of the E-Box

Replace the air filter if the temperature monitoring of the E-Box reports an increased temperature.

The following must be fulfilled or present:

- ✓ A corresponding message appears on the display.
- 1. Remove the plinth panel (pos. a) from the front.
- 2. Replace the air filter (pos. b).
- 3. Insert the plinth panel (pos. a).
- 4. Press **OK** on the display to confirm the message.

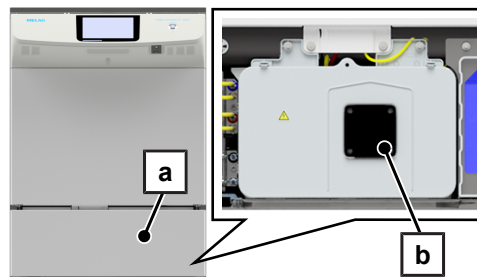

Checking the components for the reprocessing

1. Check the [components](#) used monthly, particularly their plastic parts (e.g. inserts), for damage, deposits and soiling.
2. Note any possibly deviating requirements in the respective sections of the components, see [Components for reprocessing](#) [▶ page 56].

Check for patency of the nozzles and adapters of the injector rail module

1. Check the nozzles and adapters of the injector rail module monthly for patency (no clogging).
2. To test whether the nozzles and adapters of the injector rail module are clogged/blocked, hold the nozzles and adapters vertically under a running stream of water. If the water flows unobstructed out of the nozzles or adapters, these components are clear.

Cleaning on demand

Operating unit and plastic front

Please note the following:

- Use a soft, non-fuzzing cloth.
- Use a chlorine- and vinegar-free cleaning fluid or a plastics cleaning agent.
- Check the material compatibility before application.
- Never use solvents or benzene.
- Use surface disinfectants which are suitable for plastics. Observe the manufacturer's information on the respective surface disinfectant.

Washing chamber

Please note the following:

- The washing chamber is made of high-alloy stainless steel but its surface is easily scratched.
- Clean it with a commercially-available non-abrasive stainless steel cleaning agent (no scouring cream).
- Cleaning agents containing chloride can cause corrosion in the washing chamber.
- Remove any streaks remaining on the surface after cleaning with a commercially-available stainless steel polishing spray.
- Use a soft, lint-free cloth without abrasive elements (not a scouring pad).

Pump sump

1. Remove the flat sieve and the fine sieve.
2. Remove residues and deposits from the pump sump.
3. Reinsert the fine sieve and flat sieve.
4. Start the **Rinsing** service program.
PLEASE NOTE: Avoid long standstill times (> 1 h) according to the **Rinsing** service program.

Avoiding staining

Stains on the instruments or the device can develop from poor water quality. In particular, heavy metals or chloride can result in the development of stains and/or corrosion. To avoid the development of stains and/or corrosion on the instruments or the washing chamber, MELAG recommends a final rinse with demineralised water (DI water). All water-bearing parts of the device consist of non-rusting material. This rules out the development of stains or rust caused by the device. Often, a single instrument which drops rust can suffice to cause the development of rust on other instruments or in the device. Further information is provided in the up-to-date Red Brochure "Instrument Reprocessing - Reprocessing of Instruments to Retain Value" published by the AKI. See chapter "Surface Changes: Deposits, Discoloration, Corrosion, Aging, Swelling and Stress Cracks".

Replacing the HEPA filter of the drying fan

Exceeding the permissible level of blockage can result in a worsened drying outcome. The device automatically monitors the level of blockage. If the threshold is exceeded, a display message appears.

PLEASE NOTE

For hygiene reasons, the **HEPA filter** is replaced as part of maintenance.

1. Remove the plinth panel from the front.



2. Turn the locking device (pos. a) up to the right and pull the HEPA filter (pos. b) forwards to remove it.

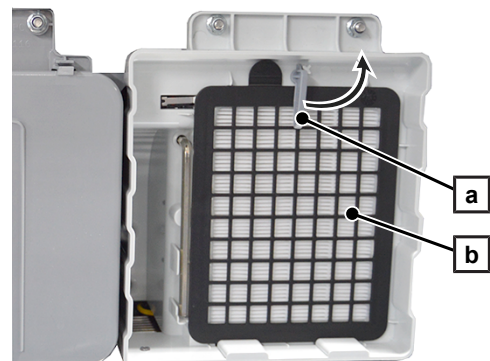

3. Insert the new HEPA filter. When inserting the new filter, ensure it is correctly seated in the grooves (pos. c). Make sure the HEPA filter sits flush (pos. b) and turn the locking device (pos. a) down.



4. Insert the plinth panel.



Maintenance

Comply with the following for safe handling:

- Maintain the specified maintenance intervals. Continuing operation beyond the maintenance interval can result in malfunctions in the device.
- Have maintenance performed only by trained and authorised technicians using the original MELAG maintenance set.
- If components that are not included in the maintenance set have to be replaced during maintenance, only original spare parts from MELAG may be used for the replacement.

Regular maintenance is vital to ensure reliable operation and value retention of the device. All function and safety-relevant components and electrical units are checked during maintenance and replaced where necessary. If a device is freely, the pure maintenance period is approx. 3 h plus trial run and any work extending beyond the normal maintenance plan.

The maintenance must be carried out regularly after 1000 cycles or 24 months at the latest.

(Process) Validation

A reproducible cleaning and disinfection result can only be ensured by proper operation (including using suitable [components](#)). The practice operator is responsible for ensuring reproducibility through the use of batch controls, routine checks and/or periodic inspections (e.g. validation).

This requirement is established in Germany, e.g. by the Medical Devices Operator Ordinance (§ 8 Para. 2 [MPBetreibV](#)), the guidelines of the [DGKH](#), [DGSV](#) and [AKI](#) and the recommendations of the [RKI](#). This requirement is also made in international regulations. This is based on [EN ISO 15883](#), which is also valid in Germany.

Comply with the national regulations and provisions applicable to you. In case of doubt, consult the relevant professional association.

- Only use the loading pattern specified and approved within the scope of the validation. Revalidation is required if loading patterns and/or components are changed.
- The use of [process agents](#) that are not recommended by MELAG (see [Process agents](#) [page 9]) may cause an increased effort for validation / performance requalification.
- We cannot provide a guarantee for non-MELAG components, even if they have been validated.
- On the MELAG Service portal, a "Recommendations for the validation of MELAtherm 20" (doc. ME_001-24) is available for validators and the technical service to download.

16 Pause times

Duration of the operating pauses

| Duration | Measure |
|---|--|
| Pauses which last longer than an hour | <ul style="list-style-type: none"> • Shut down the device |
| Longer pauses, e.g. overnight or at the weekend | <ul style="list-style-type: none"> • Open the device door slightly • Shut down the device • Close the water inlet |
| Longer than two weeks | <ul style="list-style-type: none"> • Take the device out of operation, see Decommissioning [▶ page 166] |

Decommissioning

⚠ CAUTION

Warning of chemical burns from irritant substances

Improper handling of the process agents can lead to chemical burns and health damage.

- Comply with the instructions provided by the manufacturer of the process agents.
- Protect your eyes, hands, clothing and all surfaces from contact with the process agents.

If standstill times exceed two weeks the device must be decommissioned.

The following must be fulfilled or present:

- ✓ Bucket (5 l)
 - ✓ The washing chamber is empty.
1. Fill the bucket with luke warm water.
 2. Remove the suction lances from the process agent containers and place them in the bucket. The suction lances should be immersed by a minimum of 80 %.
 3. Run the **Air removal** service program to rinse the metering system with water.
 4. Open the door and wait until the washing chamber is dry.
 5. Place the suction lances back in the process agent containers and tightly screw them shut.
 6. Make sure that the washing chamber is dry and close the door.
 7. Shut down the device.
 8. Disconnect the power plug from the socket.
 9. Turn off the water inflow.

Preparation for transport

Only allow persons authorised by MELAG to carry out the decommissioning as preparation for transport.

Recommissioning

NOTICE

Warning of malfunction

The metering system must be de-aerated during commissioning or after removal of the suction lances. De-aeration completely removes all air bubbles from the hoses and ensures fault-free metering.

- Before running the first reprocessing program, run the **Air removal** service program.
- Then start your usual reprocessing program without a load.

▶ Refer to chapter [First steps](#) [▶ page 46] for recommissioning details.

Storage and transport

⚠ CAUTION**Warning of injury**

Lifting and carrying the device incorrectly can cause spinal damage, crushing injuries and bruising.

- Carry the device with at least two people.
- Comply with the safety regulations that apply to you.
- Use the carrying handles provided to carry the device.

Comply with the following for safe handling:

- Avoid frost or extreme heat during transport and storage. If this is not ensured, before the installation and commissioning, store the unpacked device at room temperature for at least two hours.
- Avoid strong shocks/vibrations.

Transport

1. Get people authorised by MELAG to decommission the device.
2. Fit the carrying handles for transporting the device.

Recommissioning after relocation

- ▶ Get people authorised by MELAG to recommission the device.

Storage of components and spare parts

Store components for the reprocessing in a dry place, protected from corrosive objects or fluids.

Store spare parts in a dry and dust-protected place, e.g. in the packaging.

17 Malfunctions

Comply with the following for safe handling:



- Should the device issue the same malfunction message repeatedly, turn off the device and if necessary, inform your stockist.
- The device may only be serviced by ►authorised technicians.

Troubleshooting online

All messages with current descriptions can be found in the Troubleshooting portal on the MELAG website (<https://www.melag.com/en/service/troubleshooting>).



Not all notifications on the display are malfunction messages. Warnings and malfunction messages are shown on the display with an event number. This number is used for identification for assistance on the MELAG website and from the authorised technician.

| Type of message | Description |
|--|--|
|  Warning | Warnings contain instructions that help you to ensure smooth operation and to identify undesirable states. Comply with these warnings in good time to avoid malfunctions. The reprocessing result is not affected. You can continue to use the device. |
|  Malfunction message | If safe operation or successful ending of a reprocessing program are not ensured, malfunction messages are displayed. These can appear on the display shortly after starting up the device or while a program is running. If a malfunction occurs during a program run, the program will be cancelled. |

Displaying and reading messages

Minimised display:



Message list:

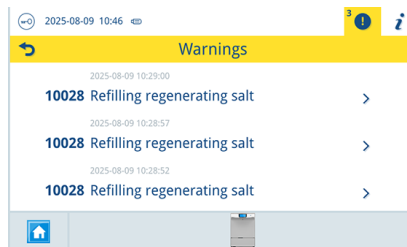

Maximised display:

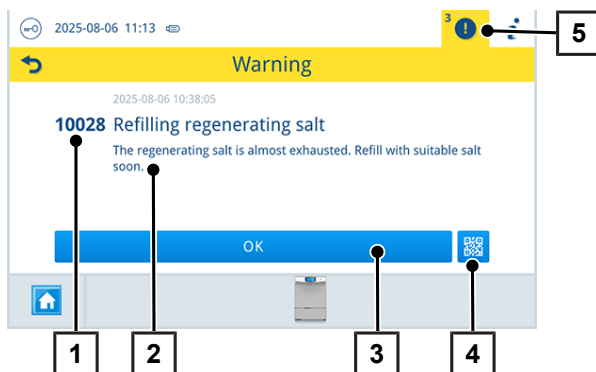
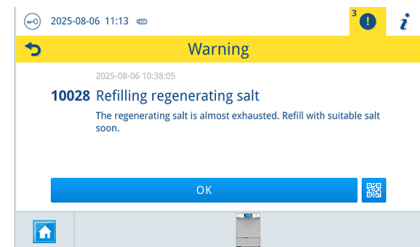



- 1 Event number
- 2 Message including description of the event
- 3 Acknowledge message
- 4 Further information is available on the Troubleshooting portal of the MELAG website
- 5 Button for opening the message list or maximised display of a message

1. In minimised display, press  or  to switch to the maximised display or to open the message list if several messages are queued.

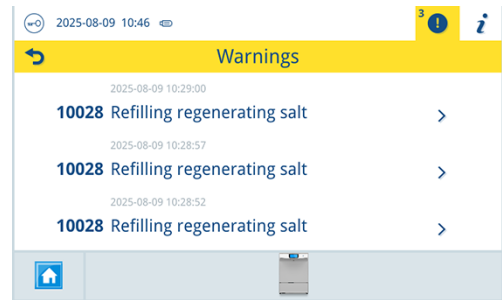

2. Press  in the message list to display the corresponding message.



3. If possible, correct the events.
4. Press  to acknowledge the message.
PLEASE NOTE: Acknowledged messages cannot be displayed again.

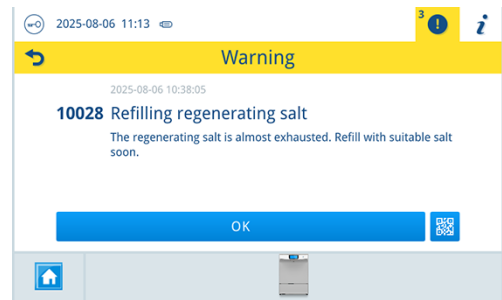

Before you phone the customer service

Follow the instructions that appear on the display in connection with a message.

The following tables indicate possible causes for certain messages/events and the corresponding operating information for their remedy. If the relevant event cannot be found in the tables below or the actions you have taken are not successful, please contact your stockist or the authorised MELAG customer service. Have the following information ready:

- the serial number of the device (see type plate or device status info),
- the event number and/or
- a detailed description of the message.

Malfunction logs

In the **Logs > Malfunction logs** menu you can view malfunction logs and output them onto a USB stick, see [Outputting program logs or malfunction logs](#) [▶ page 135].

Warnings

| Event | Possible causes | What you can do |
|----------------|---|---|
| 10006 | The fine sieve is not inserted correctly. | Insert the fine sieve correctly, see Check in the washing chamber [▶ page 160]. The arrows on the flat sieve and the fine sieve must point in the same direction towards the door. |
| 10009 | The level sensor in the water pocket (S25) indicates a too high value during condensing. The wastewater pipe is blocked, possibly due to a build-up of scale. | Check whether the wastewater pipe is blocked. |
| 10010 | The lowest settable water hardness is 3 °dH. If a water hardness of 3 °dH is set, the Regenerating service program cannot be started. | If necessary, set a higher water hardness, see Water hardness [▶ page 149]. |
| 10019 | The conductivity of the DI water is insufficient (higher than 15 µS/cm). The MELAdem 53/53 C cartridge is exhausted. | Replace the cartridge of the MELAdem 53/53 C, see MELAdem 53/53 C user manual. |
| | The DI water supply delivers insufficient deionised water. | Check the DI water supply. |
| 10021 | The level sensor of the water pocket (S25) indicates a too high value after the permissible drainage period has expired. The wastewater pipe is blocked and possibly encrusted with limescale. | Check whether the wastewater pipe is blocked. |
| 10022 | The water in the washing chamber was not pumped away in the planned time (90 s). The second attempt to pump away the water also failed. | Check whether the wastewater pipe is blocked. |
| 10028 | There is almost no regenerating salt left. | Fill regenerating salt, see Filling the regenerating salt [▶ page 49]. |
| 10029 | The salt storage is used up. No new regeneration can be performed. | Refill regenerating salt, see Filling the regenerating salt [▶ page 49]. A program can be started if the salt has dissolved in the water. After filling the regenerating salt, wait until a signal tone has sounded before starting the program. |
| 10046 | The Ophthalm o program does not start. DI water is not selected in the Settings menu. | <ol style="list-style-type: none"> 1. Connect the DI water. 2. Navigate on the display to the Settings menu > Water > Water supply at DI connection and select DI water. |
| 10047 10048 | The cleaning agent/neutraliser is used up. | <p>WARNING! Warning of contamination Using a mixture of different process agents can impair the reprocessing result. Only use process agents used to date.</p> <ol style="list-style-type: none"> 1. Replace or refill the cleaning agent/neutraliser container in compliance with health and safety regulations. 2. Start the Air removal service program. |
| 10049 | The rinse aid has been used up. | <p>WARNING! Warning of contamination Using a mixture of different process agents can impair the reprocessing result. Only use process agents used to date.</p> <ol style="list-style-type: none"> 1. Refill the storage container for the rinse aid in compliance with the health and safety regulations. 2. Start the Air removal service program. |
| 10053 | The rinse aid suction lance rinse aid sucks in air. | Dip the black suction lance into the rinse aid. |

| Event | Possible causes | What you can do |
|----------------|---|--|
| 10056 | During disinfection in the Ophthalm program, insufficient conductivity (> 15 µS/cm and < 25 µS/cm) was measured in the washing chamber. The cause could be carrying over of process agent, regenerating salt or deposits. The program was ended successfully despite a warning. | <ol style="list-style-type: none"> 1. Close the lid of the salt container correctly. 2. Align the containers with the opening facing downwards in the device. 3. Before reprocessing, check the hollow bodies for patency and correct fit. 4. Clean the filter discs in the connection devices for instruments. 5. Remove and clean the flat sieve and the fine sieve, see Check in the washing chamber [▶ page 160]. |
| 10061 | The water inflow is too low. | <ol style="list-style-type: none"> 1. Check the water inflow of the device. 2. Open the water tap completely. |
| 10070 | The HEPA filter may be blocked. | <p>Replace the HEPA filter, see Replacing the HEPA filter of the drying fan [▶ page 164].</p> <p>If this occurs repeatedly, please contact the technical service.</p> |
| 10072 | Insufficient water inflow. The water tap has not been opened completely. The cold water inlet hose is kinked. | <p>Check the water inflow of the device.</p> <ol style="list-style-type: none"> 1. Open the water tap completely. 2. Check the laying of the cold water inlet hose. |
| | The sieve in the cold water inlet hose is blocked. | Clean the sieve in the cold water inlet hose. |
| | There is a build-up of scale on the water inlet in the water pocket. | The feed water line must be descaled. Please contact technical service. |
| 10086 10091 | The maximum permissible maintenance period (24 months) or the maximum permissible number of cycles (1000 cycles) was reached since commissioning or since the last maintenance. | Arrange a maintenance appointment with an authorised technician. You can continue to start the device. |
| 10229 | The door of the device is not closed correctly. No program can be started. | <ol style="list-style-type: none"> 1. Shut down the device and the start it up again. 2. If necessary, operate the manual door emergency opening, see Manual door emergency opening [▶ page 176]. |
| 11000 | The USB stick does not function properly. The system does not detect a USB stick or cannot read it. | Use a different USB stick. |
| | The er USB stick is not formatted in the FAT32 file system. | Format the USB stick in FAT32 format. |
| 11001 | USB sticks are connected to both USB ports (front and rear of the device). | Remove one USB stick. |
| 11002 | There is no USB stick connected to any USB port (front and rear of the device). | Connect a USB stick to a USB port. |
| 11003 | The USB stick memory is full. No further logs can be saved. | <ol style="list-style-type: none"> 1. Back up the data on the USB stick in the practice network. 2. Delete the logs from the USB stick to create memory space for new logs. |
| 11004 | The system is unable to find a USB stick for the log output. | Connect a USB stick to the device. |
| 11005 | The system is unable to find a TFS client for the log output. | Configure a TFS client for the device. |
| 11006 | The internal log memory of the device is full. All logs have not yet been output. | <p>Output the internally stored logs to a USB stick or to your practice network.</p> <p>The logs can also be output automatically. Set automatic log output in the Settings menu, see Log output [▶ page 142].</p> |

| Event | Possible causes | What you can do |
|-------|---|--|
| 11100 | The log output was cancelled due to a connection error. | Check the connection of the device to the practice network via the network interface on the back of the device. |
| 11200 | The system is unable to find a USB stick for the installation. | Connect a USB stick with the valid installation data to the device. |
| 11201 | The system is unable to find valid installation data on the USB stick. | Connect a USB stick with the valid installation data to the device. |
| 11202 | The system finds multiple installation data on the USB stick. | Connect a USB stick with only one valid installation data set to the device. |
| 11203 | The installation data provided are incompatible or corrupt. | Check the installation data on the USB stick. |
| 13004 | The partial cycle is parameterised with DI water. DI water is not selected in the Settings menu. | <ol style="list-style-type: none"> 1. Connect the DI water. 2. Navigate on the display to the Settings menu > Water > Water supply at DI connection and select DI water. <p>Alternatively, please contact the technical service.</p> |

Malfunction messages

| Event | Possible causes | What you can do |
|-------|--|---|
| 10001 | The rinse arm is mechanically blocked. | Check the rinse arm for freedom of movement. |
| | The drive nozzle of the rinse arm is blocked. | Remove the rinse arm and clean it, see Check in the washing chamber [▶ page 160]. |
| | The basis baskets are not inserted, or not in the correct position. | Insert the basis baskets correctly. If using the injector rail module, it must be docked onto the connector in the washing chamber, see Injector rail module [▶ page 85]. |
| | There are fine deposits in the rinse arm bearing or in the sliding disc. | Remove the rinse arm and clean it, see Check in the washing chamber [▶ page 160]. |
| | There is no magnet in the magnet holder on the rinse arm. | Check the magnets and reinsert them if necessary, see Rinse arms magnet holders [▶ page 177]. |
| 10002 | The rinse arm is mechanically blocked. | Check the rinse arm for freedom of movement. |
| | The drive nozzle of the rinse arm is blocked. | Remove the rinse arm and clean it, see Check in the washing chamber [▶ page 160]. |
| | The basis baskets are not inserted, or not in the correct position. | Insert the basis baskets correctly. If using the injector rail module, it must be docked onto the connector in the washing chamber, see Injector rail module [▶ page 85]. |
| | There are fine deposits in the rinse arm bearing or in the sliding disc. | Remove the rinse arm and clean it, see Check in the washing chamber [▶ page 160]. |
| | There is no magnet in the magnet holder on the rinse arm. | Check the magnets and reinsert them if necessary, see Rinse arms magnet holders [▶ page 177]. |
| | If using the injector rail module, under unfavourable load conditions, the rinse arm can be stopped by water jets. | <ol style="list-style-type: none"> 1. Close off unused injector nozzles with silicone closure caps. 2. Check the alignment of the load, for example, surgical aspirators. |
| | A middle rinse arm is not installed. | Deactivate the program options before starting the Middle rinse arm monitoring program, see Starting and monitoring the program [▶ page 127]. |

| Event | Possible causes | What you can do |
|---|---|---|
| 10005 | The rinse arm is mechanically blocked. | Check the rinse arm for freedom of movement. |
| | The drive nozzle of the rinse arm is blocked. | Remove the rinse arm and clean it, see Check in the washing chamber [▶ page 160]. |
| | The basis baskets are not inserted, or not in the correct position. | Insert the basis baskets correctly. If using the injector rail module, it must be docked onto the connector in the washing chamber, see Injector rail module [▶ page 85]. |
| | There are fine deposits in the rinse arm bearing or in the sliding disc. | Remove the rinse arm and clean it, see Check in the washing chamber [▶ page 160]. |
| | There is no magnet in the magnet holder on the rinse arm. | Check the magnets and reinsert them if necessary, see Rinse arms magnet holders [▶ page 177]. |
| | If using the injector rail module, under unfavourable load conditions, the rinse arm can be stopped by water jets. | <ol style="list-style-type: none"> 1. Close off unused injector nozzles with silicone closure caps. 2. Check the alignment of the load, for example, surgical aspirators. |
| 10007 | The rinse pressure in the washing chamber is too low. | Check the correct position of the upper basket and its contact at the connector in the washing chamber. |
| | The upper basket is not inserted correctly. | |
| | The injector rail module is not inserted correctly. | Insert the injector rail module correctly into the lower basket, see Injector rail module [▶ page 85]. |
| | Too many connections on the injector rail module are unused and unsealed. | Seal the unused connections of the injector rail module with a screw plug. |
| | The flat sieve, the fine sieve or the central filter are contaminated. | Remove and clean the flat sieve, fine sieve and the central filter, see Check in the washing chamber [▶ page 160]. |
| | Large containers with the opening pointing upwards may have been sorted into the device. This diverts water from the rinsing process. | Sort the containers in the device with their openings facing downwards. |
| | Strong foam generation: The instruments have been pre-cleaned with a foam-generating solution and have then been subject to insufficient rinsing. | Rinse the instruments thoroughly before reprocessing. |
| Strong foam generation: Unsuitable process agents (rinse aid or cleaning agent) have been used. | <p>WARNING! Warning of contamination Heavy foaming prevents adequate rinsing of the instruments.</p> <p>Use only those process agents suitable for the device.</p> | |
| 10018 | The door of the device is blocked and cannot be closed correctly. | Check the door area for obstacles. |
| 10020 | The conductivity of the DI water is insufficient (higher than 60 µS/cm). | Replace the cartridge of the MELAdem 53/53 C, see MELAdem 53/53 C user manual. |
| | The MELAdem 53/53 C cartridge is exhausted. | |
| | The DI water supply delivers insufficient deionised water. | Check the DI water supply. |

| Event | Possible causes | What you can do |
|---|---|--|
| 10023 | The rinse pressure in the washing chamber is too low. Insufficient water inflow. | Check the water inflow of the device. Open the water tap completely. 1. Check the water inflow of the device. 2. Open the water tap completely. |
| | The basis baskets are not inserted, or not in the correct position. | Insert the basis baskets correctly. If using the injector rail module, it must be docked onto the connector in the washing chamber, see Injector rail module [▶ page 85]. |
| | Too many connections on the injector rail module are unused and unsealed. | Seal the unused connections of the injector rail module with a screw plug. |
| | The flat sieve or the fine sieve is soiled. | Remove and clean the flat sieve and the fine sieve, see Check in the washing chamber [▶ page 160]. |
| | Large containers with the opening pointing upwards may have been sorted into the device. This diverts water from the rinsing process. | Sort the containers in the device with their openings facing downwards. |
| | Strong foam generation: The instruments have been precleaned with a foam-generating solution and then rinsed insufficiently. | Rinse the instruments thoroughly before reprocessing. |
| | Strong foam generation: The filter disc in the universal adapter for transmission instruments is heavily soiled. | Replace the soiled ceramic filter disc, see Universal adapter incl. 3 inserts and ceramic filter disc [▶ page 103]. Clean the metal filter disc, see Metal filter disc [▶ page 110]. |
| Strong foam generation: Unsuitable process agents (rinse aid or cleaning agent) have been used. | WARNING! Warning of contamination Heavy foaming prevents adequate rinsing of the instruments. Use only those process agents suitable for the device. | |
| 10030 | The temperature during precleaning is too high. | Check the water supply to the device. The device must not be connected to the hot water. |
| 10031 | Liquid was detected in the floor trough of the device. | CAUTION! Warning of chemical burn from irritant substances Contact with liquids in the floor trough can cause chemical burns. 1. Avoid contact with liquids in the floor trough; they can contain process agents. 2. Shut down the device. 3. Close the water tap. 4. Please contact the technical service. |
| 10032 | During a program run, the water level in the washing chamber measured was too high. | 1. Close the water tap. 2. Please contact the technical service. |
| 10043 10044 | No cleaning agent/neutraliser is pumped. The container of the cleaning agent/neutraliser is empty or almost empty. | WARNING! Warning of contamination A mixture of different process agents can impair the reprocessing result. Only use process agents used to date. 1. Replace or refill the cleaning agent/neutraliser container in compliance with health and safety regulations. 2. Start the Air removal service program. |
| | The hose to the suction lance is kinked. | 1. Eliminate any kinks or pinch points on the process agent hoses. 2. Start the Air removal service program. |
| | Air bubbles have developed in the metering system after long standstill times. | Start the Air removal service program. |

| Event | Possible causes | What you can do |
|-------------------------|---|---|
| 10050 | The cleaning agent suction lance sucks in air. | Dip the blue suction lance into the cleaning agent. |
| 10051 | The neutraliser suction lance sucks in air. | Dip the red suction lance into the neutraliser. |
| 10057 | The conductivity of the DI water is insufficient (higher than 60 µS/cm). The MELAdem 53/53 C cartridge is exhausted. | Replace the cartridge of the MELAdem 53/53 C, see MELAdem 53/53 C user manual. |
| | The DI water supply delivers insufficient deionised water. | Check the DI water supply. If this occurs repeatedly, please contact the technical service. |
| 10064 | The USB stick was removed during the update process. | Leave the USB stick in the device for the whole update process. |
| 10098 10099 | WARNING! Warning of contamination The running program was interrupted due to a power failure. The load is deemed not to be disinfected. | 1. Press OK to acknowledge the message. 2. Start the program again. |
| 10121 | After pumping out there is water in the pump sump. The flat sieve or the fine sieve is soiled. | Clean the flat sieve and the fine sieve, see Check in the washing chamber [▶ page 160]. |
| | The outlet hose is kinked or blocked. | Lay the outlet hose without kinks and remove any blockages. |
| 10183 10209 10210 | Software error | Restart the device by pressing the Power button and keeping it pressed for several seconds. If this occurs repeatedly, please contact the technical service. |
| 11010 | The device is operated in an ambient temperature that is too cold. | Note the permissible ambient temperature (5-40 °C), see Technical data. |
| 11014 | The device is operated in an ambient temperature that is too hot. | Note the permissible ambient temperature (5-40 °C), see Technical data. |
| 12004 | A malfunction message was not acknowledged before shutting down the device. | Press OK to acknowledge the queued malfunction message. |
| 12006 | The date and time are invalid. | Check the settings in the Settings menu, see Date and time [▶ page 140]. |
| 13001 13003 | Insufficient water inflow. | Check the water inflow of the device. |
| | The water tap has not been opened completely. | Open the water tap completely. |
| | The sieve in the cold water inlet hose is blocked. | Remove and clean the sieve in the cold water inlet hose. |
| | There is a build-up of scale on the water inlet in the water pocket. | The feed water line must be descaled. Please contact technical services. |
| | The cold water inlet hose is kinked. | Check the laying of the cold water inlet hose. |
| 19999 | Software error | Restart the device by pressing the Power button and keeping it pressed for several seconds. If this occurs repeatedly, please contact the technical service. |

Manual door emergency opening

In the event of a power failure or malfunction, you can open the door manually via the emergency opening.

Comply with the following for safe handling:

- Escaping steam brings the danger of scalding.
- Never operate the door emergency-opening mechanism during an active program.
- If a program is aborted by the emergency door opening, this is classed as not having been completed successfully. The instruments must be reprocessed again.
- Wear suitable personal protective equipment (e. g. gloves and goggles).

Operating the door emergency-opening

1. Shut down the device.
2. Remove the plinth panel from the front.



3. Remove the Allen key (5 mm).

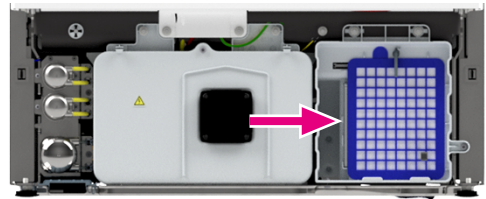

4. Press the Allen key firmly into the opening below the door handle. **PLEASE NOTE:** It is not necessary to turn the Allen key.



5. Place the Allen key back in the plinth and insert the panel.

➡ After an emergency opening, the door cannot be closed again and locked until the device is supplied with power.

Rinse arms magnet holders

The magnetic holders on the rinse arms are used for speed monitoring. If a message concerning reduced speed of a rinse arm appears on the display repeatedly despite action taken to correct the malfunction, the check the magnet holder.

Fit of the magnet holder

Each rinse arm is equipped with a magnet holder including magnet. There are two versions.

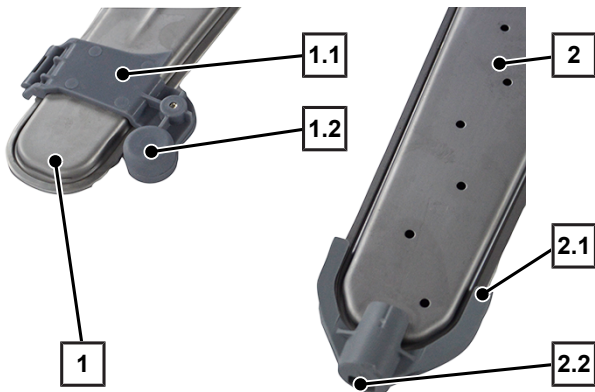

- 1 Upper rinse arm
- 1.1 Magnetic holder
- 1.2 Magnet
- 2 Middle rinse arm, lower rinse arm
- 2.1 Magnetic holder
- 2.2 Magnet

Check the magnet holder on the middle/lower rinse arm

1. Undo the latching lug (pos. a) of the magnet holder and insert the magnet (pos. b) correctly.
2. Reinsert the latching lug (pos. a) of the magnet holder.
3. Check the magnet holder for tight fit.

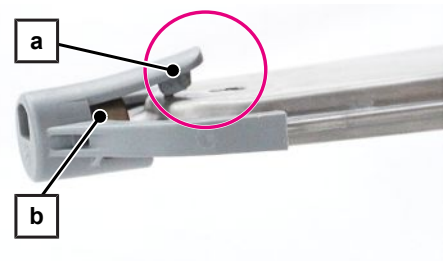

Check the magnet holder on the upper rinse arm

The following must be fulfilled or present:

- ✓ Torx key (TX20)

 1. Undo the screw (pos. a) of the magnet holder (pos. b).
 2. Insert the magnet (pos. c) correctly.
 3. Check the magnet holder (pos. b) for tight fit.

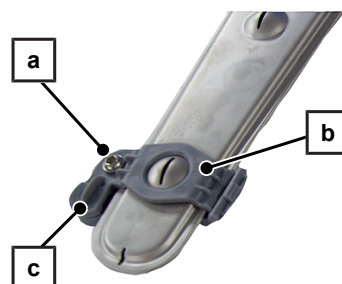

18 Technical data

| Device version | Semi-integrated unit ^{*)} | Free-standing ^{**)} |
|---------------------------------------|------------------------------------|---------------------------------|
| Device dimensions (H x W x D) | 81.8 x 59.8 x 73.0 cm | 83.6 x 59.8 x 73.0 cm |
| Empty weight | 78 kg | 86 kg |
| Operating weight | approx. 129 kg | approx. 137 kg |
| Max. floor loading (normal operation) | approx. 32.3 kg per device foot | approx. 34.3 kg per device foot |

^{*)} without stainless steel cover plate | ^{**)} with stainless steel cover plate

| Device type | MELAtherm 20 (215) |
|--|--|
| Washing chamber | |
| Dimensions (H x W x D) | 51.1 x 50.9 x 53.9 cm ³ |
| Volume of the washing chamber | 160 l |
| Max. load of the door | 40 kg |
| Electrical connection | |
| Power supply | 3N AC 380-415 V (±10 %), 50 Hz |
| Max. voltage range | 360-440 V |
| Electrical power | 9100 W |
| Building fuses | 3x 16 A, separate electric circuit, Type B fusing, additional residual current device type F or higher with 30 mA according to national requirements |
| Overvoltage category | transient overvoltages up to the values of overvoltage category II |
| Long power cable | 2 m |
| Air pollution degree (acc. to EN 61010-1) | Category 2 |
| Ambient conditions | |
| Installation location | interior of a building |
| Max. noise emission (drying) | <73 dB(A) |
| Noise emission (average value) | <66.2 dB(A) |
| Waste heat (with max. solid load) | 1.186 kWh |
| Ambient temperature | 5-40 °C (ideal range 16-26 °C) |
| Air pressure | 750-1060 mbar |
| Relative humidity | max. 80 % at temperatures of up to 31 °C, max. 50 % at 40 °C (decreasing in linear fashion in-between) |
| Degree of protection (acc. to IEC 60529) | IP20 |
| Max. altitude | 2000 m |
| Cold water/DI water | |
| Cold water connection | 3/4" Internal thread (for connection to a standard 3/4" connection with external thread) |
| DI water connection | 3/4" External thread (for connection of a pressure resistant hose with 3/4" internal thread) |
| Cold water quality | Drinking water according to the German Drinking water Ordinance (TrinkwV, Trinkwasserverordnung) or local regulations |
| DI water quality (max. permissible conductivity) | from 15 µS/cm warning, from 60 µS/cm malfunction, Ophthalmo: from 25 µS/cm malfunction |
| Max. water hardness | 30 °dH |
| Min. volume flow | 2 l/min |
| Recommended volume flow | 8 l/min |
| Max. water pressure (static) | 10 bar |
| Cold water temperature | 1-26 °C |

| | |
|-----------------------------|---------------------------------------|
| Device type | MELAtherm 20 (215) |
| Wastewater | |
| Wastewater connection | DN21 |
| Max. wastewater temperature | 93 °C (<1 min, approx. 11 l) |
| Amount of wastewater | approx. 60 l/h (at smaller intervals) |
| Drain pump capacity | 16 l/min |

19 Components, accessories and spare parts

All specified articles are available through specialist dealers.

Components

| Category | Article | Art. no. |
|--|--|----------|
| Basis baskets | Upper basket | ME80820 |
| | Lower basket | ME80830 |
| Injector rail | Injector rail module | ME80840 |
| DIN sieve trolley | MELAtherm 20 DIN sieve trolley | ME80850 |
| Holders | Universal holder Flex 1 incl. 3 brackets | ME80134 |
| | Universal holder Flex 1 (low) incl. 3 brackets | ME80234 |
| | Universal holder Flex 2 incl. 5 brackets | ME80135 |
| | Universal holder Flex 2 (low) incl. 5 brackets | ME80235 |
| | Universal holder Flex 3 incl. 7 brackets | ME80136 |
| | Universal holder Flex 3 (low) incl. 7 brackets | ME80236 |
| | Universal holder Flex 4 incl. 9 brackets | ME80137 |
| | Universal holder Flex 4 (low) incl. 9 brackets | ME80237 |
| | Holder for 5 trays / 10 half trays | ME80590 |
| Instrument baskets | Instrument basket G | ME00131 |
| | Instrument basket standard | ME00184 |
| | Tip protection for instrument basket | ME00186 |
| | Instrument basket compact | ME00195 |
| Small parts basket | Small parts basket Standard | ME00133 |
| | Small parts basket Comfort | ME80001 |
| | Bur holder (for Small parts basket Comfort) | ME80002 |
| Stackable holders and baskets (Flex system) | Flex basket 1 | ME80010 |
| | Flex basket 2 | ME80020 |
| | Flex basket 3 | ME80030 |
| | Flex basket 4 | ME20670 |
| | Flex basket 6 | ME80255 |
| | Flex basket 8 | ME80256 |
| | Flex basket specula | ME80410 |
| | Flex supplementary basket | ME80120 |
| | Holder for impression trays and instruments with joints | ME80110 |
| | Instrument holder for Flex baskets (60 pcs.) | ME80395 |
| Top frames for stackable baskets (Flex system) | Top frame for ear specula Flex 1 (mesh size 14 mm) | ME80070 |
| | Top frame for ear specula Flex 1 (mesh size 20 mm) | ME80080 |
| | Top frame for ear specula Flex 2 (mesh size 20 mm) | ME80090 |
| | Top frame for ear specula Flex 3 (mesh size 20 mm) | ME80100 |
| | Fixing clamp for top frames | ME80420 |
| | Top frame for nasal specula Flex 1 incl. 2 fixing clamps | ME80435 |

| Category | Article | Art. no. | |
|---|---|----------------------------------|---------|
| MELAstore Tray and silicone bars | MELAstore Tray 33 (8.4 x 17.9 x 3.2 cm) | ME01176 | |
| | MELAstore Tray 50 (17.9 x 12.8 x 3.2 cm) | ME01177 | |
| | MELAstore Tray 100 (28 x 17.9 x 3.2 cm) | ME01178 | |
| | MELAstore Tray 200 (28 x 17.9 x 4.3 cm) | ME01179 | |
| | Protective cover MELAstore Tray OTS / Lid OTS light | ME01187 | |
| | MELAstore Tray Ophthalmology light | ME01188 | |
| | MELAstore Tray Ophthalmology | ME01189 | |
| | Mount identification plate for MELAstore Tray | ME01197 | |
| | Silicone bar, yellow, MELAstore Tray Ophthalmology/100/50/33 (2 pcs.) | ME82931 | |
| | Silicone bar, red, MELAstore Tray Ophthalmology/100/50/33 (2 pcs.) | ME82932 | |
| | Silicone bar, purple, MELAstore Tray Ophthalmology/100/50/33 (2 pcs.) | ME82933 | |
| | Silicone bar, green, MELAstore Tray Ophthalmology/100/50/33 (2 pcs.) | ME82934 | |
| | Silicone bar, yellow, MELAstore Tray 200 (2 pcs.) | ME82941 | |
| | Silicone bar, red, MELAstore Tray 200 (2 pcs.) | ME82942 | |
| | Silicone bar, purple, MELAstore Tray 200 (2 pcs.) | ME82943 | |
| | Silicone bar, green, MELAstore Tray 200 (2 pcs.) | ME82944 | |
| | Silicone bar, blue, MELAstore Tray Ophthalmology/100/50/33 (2 pcs.) | ME82990 | |
| | Silicone bar, blue, MELAstore Tray 200 (2 pcs.) | ME82991 | |
| | Connectors and adapters for instruments | Clamp spring for injector nozzle | ME00196 |
| | | Injector nozzle | ME73860 |
| Rinse sleeve incl. 5 inserts | | ME80260 | |
| Luer adapter (male) | | ME73880 | |
| Luer-Lock adapter (male) | | ME74130 | |
| Luer/Luer-Lock adapter (female) | | ME67250 | |
| Adapters for tips and ultrasonic handpieces: | | -- | |
| Adapter for KaVo eScaler | | ME12411 | |
| Adapter M3.0 x 0.5 mm, external thread | | ME80750 | |
| Adapter M3.6 x PH1.5 P0.5, internal thread | | ME80751 | |
| Adapter M3.0 x 0.35 mm, external thread | | ME80752 | |
| Adapter M3.0 x 0.35 mm, internal thread | | ME80753 | |
| Adapter M3.5 x 0.35 mm, internal thread | | ME80755 | |
| Adapter M3.0 x 0.6 mm, external thread | | ME80756 | |
| Adapter M3.0 x 0.6 mm, internal thread | | ME80757 | |
| Adapter M3.5 x 0.6 mm, internal thread | | ME80760 | |
| Adapter M3.5 x 0.6 mm, external thread | | ME80771 | |
| Adapter M3.0 x 0.5 mm, internal thread | | ME80790 | |
| Marking discs for adapters (green, blue and yellow, 6 pcs.) | | ME80769 | |

| Category | Article | Art. no. |
|--|--|--|
| Adapters for transmission instruments | Distance sleeve | ME55120 |
| | Universal adapter incl. 3 inserts and ceramic filter disc | ME73904 |
| | Instrument holder for universal adapter (retaining ring incl. 3 silicone strips) | ME22968 |
| | Filter disc housing incl. ceramic filter disc | ME73905 |
| | Adapter for external spray channels | ME74135 |
| | Adapter for ISO connector (INTRA) | ME80610 |
| | Adapter for turbines NSK connector | ME80612 |
| | Adapter for EMS AIR-FLOW Handy 3.0 | ME80613 |
| | Adapter for EMS AIR-FLOW Prophylaxis Master | ME80614 |
| | Adapter for NSK Prophy Mate Neo (airflow) | ME80616 |
| | Adapter for NSK Varios Combi Pro (airflow) | ME80617 |
| | Adapter for Sirona T1 Classic | ME80620 |
| | Adapter for KaVo/BienAir contra angle heads | ME80630 |
| | Adapter for turbines W&H connector (Roto Quick) | ME80640 |
| | Adapter for turbines Sirona connector | ME80650 |
| | Adapter for turbines KaVo connector (MULTIflex) | ME80660 |
| | Adapter for Sirona Sprayvit nozzle | ME80802 |
| | Adapter for KaVo multifunctional cannula | ME80803 |
| | Adapter for MyLunos powder water jet nozzle | ME80804 |
| | Distributor | Triple distributor (without filter disc) |
| Triple distributor incl. ceramic filter disc | | ME73903 |
| Injector basket Flex 1 | | ME80740 |
| Filter inserts | Ceramic filter disc (10 pcs.) | ME64375 |
| | Metal filter disc | ME80350 |
| | Central filter for MELAtherm 20 | ME84650 |
| Closure elements | Screw plug for injector rail and distributors | ME80140 |
| | Closure (male) for Luer-Lock | ME80170 |
| | Closure (female) for Luer/Luer-Lock | ME80180 |
| | Silicone closure cap, green (10 pcs.) | ME89051 |
| | Silicone closure cap, blue (10 pcs.) | ME89061 |
| | Silicone closure cap, white (10 pcs.) | ME89071 |
| Hoses and hose connections | Hose connector (6 mm) with external thread | ME80150 |
| | Hose connector (6 mm) with internal thread | ME80160 |
| | Silicone hose (10/6 mm), 2 m | ME80190 |
| | Silicone hose (10/6 mm) with connectors, 0.5 m (including one hose connection each with internal thread and external thread) | ME80195 |

Accessories

| Category | Article | Art. no. |
|----------------|---|----------|
| Process agents | MEtherm 51 (mildly-alkaline enzymatic cleaning agent) | ME11630 |
| | MEtherm 55 C (citric acid-based neutraliser) | ME11621 |
| | MEtherm 61 (rinse aid) | ME11627 |

Other equipment

| Category | Article | Art. no. |
|----------------------------------|---|----------|
| Water treatment | MELAdem 53 C with 2 containers (15 l each) | ME01036 |
| | MELAdem 53 with 2 containers (20 l each) | ME01038 |
| | Regenerating salt for MELAtherm | ME80000 |
| | Water inlet dirt trap | ME80050 |
| Test body system | MELAcontrol Wash Check (100 indicators) | ME01072 |
| | Holder Wash Check for external cleaning | ME01073 |
| | Holder Wash Check for internal cleaning | ME01074 |
| Documentation | Network cable, 1.5 m | ME15812 |
| | Network cable, 5 m | ME15814 |
| | Network cable, 10 m | ME15815 |
| | USB stick | ME19901 |
| | USB cable, 1.8 m | ME19902 |
| Instrument care | MELAG Care Oil Spray | ME22935 |
| Process agents | Key for container lid/salt container | ME11906 |
| | MediaGuard Box | ME80232 |
| Installation | Water stop (leakage water detector with shut-off valve and probe) | ME01056 |
| | Extension for water inflow hose (3 m) | ME24933 |
| | Double-chamber siphon | ME26635 |
| | Stainless steel cover plate for MELAtherm 20 (incl. wall mount) | ME65320 |
| | Test set for water hardness | ME71000 |
| | Outlet hose (4 m) | ME76410 |
| MELAstore Tray and silicone bars | Identification plate for MELAstore Tray and Box | ME01195 |
| | Mount identification plate for MELAstore Tray | ME01197 |

Spare parts

| Category | Article | Art. no. |
|--------------------|--|----------|
| Device in general | MELAtherm 20 carrying handle (4 pcs.) | ME23771 |
| | Moisture barrier (adhesive tape) | ME23797 |
| | Hook and loop cable ties (black) (5 pcs.) | ME23800 |
| | Vapour barrier plate | ME23815 |
| | Allen key for door emergency opening | ME36810 |
| | Y-fitting for water supply with seal | ME37315 |
| | HEPA-Filter für MELAtherm / Cooling Box (for MELAtherm 20 activeDRY) | ME51240 |
| | Water outlet hose (2 m) | ME60580 |
| | Rinse aid storage container (1 l) | ME60910 |
| | Funnel for salt container | ME68200 |
| | Indication label for process agent (3 pcs.) | ME80605 |
| | Magnetic pocket for device logbook | ME85600 |
| Holders | Bracket for universal holder | ME80133 |
| | Bracket for Universal holder (low) | ME80233 |
| Small parts basket | Silicone mesh for bur holder (2 pcs) | ME22155 |

| Category | Article | Art. no. |
|--|---|----------|
| MELAstore Tray and silicone bars | Lid handle MELAstore Tray Ophthalmology | ME12423 |
| | Luer connection (male) MELAstore Tray Ophthalmology | ME12431 |
| | Luer connection (female) MELAstore Tray Ophthalmology | ME12432 |
| | Silicone hose (internal) 500 mm MELAstore Tray Ophthalmology | ME12435 |
| | Closure set MELAstore Tray Ophthalmology | ME22999 |
| | Silicone bar for MELAstore Tray 50 ^{*)} | ME82960 |
| | Silicone bar wave profile for MELAstore Tray 50/100 ^{*)} | ME82961 |
| | Silicone bar for MELAstore Tray 100 ^{*)} | ME82970 |
| | Silicone bar downholder for MELAstore Tray 50/100 ^{*)} | ME82971 |
| | Silicone bar for MELAstore Tray 200 ^{*)} | ME82980 |
| ^{*)} Silicone bars only fit MELAstore Trays with long holes | | |
| Connectors and adapters for instruments | Silicone insert for rinse sleeve (2 mm), yellow (5 pcs.) | ME80290 |
| | Silicone insert for rinse sleeve (4 mm), green (5 pcs.) | ME80300 |
| | Silicone insert for rinse sleeve (6 mm), blue (5 pcs.) | ME80310 |
| | Silicone insert for rinse sleeve (8 mm), grey (5 pcs.) | ME80320 |
| | Silicone insert for rinse sleeve (10 mm), red (5 pcs.) | ME80330 |
| Adapters for transmission instruments | Holding sleeve for EMS AIR-FLOW Prophylaxis Master | ME22963 |
| | Seal for EMS AIR-FLOW Prophylaxis Master | ME22964 |
| | Clip and spring for EMS AIR-FLOW adapter | ME22965 |
| | Silicone insert for universal adapter, green (Ø 16 mm) | ME63500 |
| | Silicone insert for universal adapter, blue (Ø 20 mm) | ME63501 |
| | Silicone insert for universal adapter, white (Ø 22 mm) | ME63502 |
| Distributor | Silicone insert for triple distributor, yellow (Ø 19 mm) | ME63503 |

Glossary

A0-value

The A0 value represents a standard for the elimination of microorganisms and the deactivation of viruses in the disinfection procedure with damp heat. The A0 value depends on temperature and time.

Accessory

Accessories are independent articles that are used with one or several medical devices. Accessories specifically and directly assist the intended purpose of the medical device.

AKI

AKI is the abbreviation for "Arbeitskreis Instrumentenaufbereitung" [Instrument Reprocessing Working Group].

Authorised technician

An authorised technician is a person intensively trained and authorised by MELAG who has sufficient specific device and technical knowledge. to perform maintenance and installation work on MELAG devices. Only they may carry out this work.

Batch

The batch is the composition of items which has been subject to the same reprocessing procedure.

BfArM

BfArM is the abbreviation for "Bundesinstitut für Arzneimittel und Medizinprodukte" [Federal Institute for Drugs and Medical Devices] in Germany.

Cleaning agent

A cleaning agent (e.g. MEtherm 50, MEtherm 51) is a substance or mixture of chemical substances that assist in the cleaning of medical devices.

Competent personnel

Trained personnel in accordance with national specifications for the respective area of application (dentistry, medicine, podiatry, veterinary medicine, cosmetics, piercing, tattoo) with the following contents: knowledge of instruments, hygiene and microbiology, risk assessment and classification of medical devices and instrument reprocessing.

Component

A component is a part of a medical device, which is delivered with it but is not permanently connected to it. A component supports or achieves the intended purpose of the medical device for at least one use case. It is not an independent accessory or medical device.

Conductivity

Conductivity is the ability of a conductive chemical substance or mixture of substances to conduct or transfer energy or other substances or particles in space.

DGKH

DGKH is the abbreviation for "Deutsche Gesellschaft für Krankenhaushygiene e.V." [German Society for Hospital Hygiene].

DGSV

DGSV is the abbreviation for "Deutsche Gesellschaft für Sterilgutversorgung" [German Society for Sterile Supply]. The training guidelines of the DGSV are listed in DIN 58946, Part 6 as requirements for personnel.

DI water

Demineralsised water (DI water) is water (H₂O) without the salts found in normal spring and tap water, which are dissolved as anions and cations.

Effectiveness range

The effectiveness of disinfection measures and agents against pathogens is divided by the Robert Koch Institute into microbiological effect ranges. The effective ranges are identified by the letters A, B, C and D, see RKI.

EN 1717

Standard for "Protection against pollution of potable water installations and general requirements of devices to prevent pollution by back flow"

EN ISO 15883

Standard for "Washer-disinfectors"

EN ISO 17664

Standard for "Processing of health care products – Information to be provided by the medical device manufacturer for the processing of medical devices"

Equipment

Equipment is an article that can be used with the medical device, however, it is not necessary for assisting and/or achieving the intended purpose of the medical device. It is not an independent accessory or medical device.

FTP

FTP (File Transfer Protocol) is a data transmission procedure serving to transfer data from the Internet. This data can include programs, files or even information. Special FTP programs (FTP clients) serve to load the data onto a server.

HEPA filter

The HEPA filter is a filter group H filter element (particulate material filter), in accordance with EN 1822-1. This group is sub-divided into two classes, H13 and H14. Filter elements are classified in accordance with their filter capacity. The HEPA filter is used in medical environments to purify the air microbiologically from suspended particles.

IEC 61326-1

Standard for "Electrical equipment for measurement, control and laboratory use - EMC requirements - Part 1: General requirements"

KRINKO

KRINKO is the abbreviation for "Kommission für Krankenhaushygiene und Infektionsprävention" [Commission for Hospital Hygiene and Infection Prevention] at the Robert Koch Institute in Germany.

Load

The load includes products, equipment, or materials that are reprocessed together in one operating cycle.

Medical device

Medical device means any instrument, apparatus, appliance, software, implant, reagent, material or other article intended by the manufacturer to be used, alone or in combination, for human beings for one or more of the specific medical purposes in accordance with Regulation (EU) 2017/745 Article 1, Paragraph 4.

MPBetreibV

MPBetreibV is the abbreviation for "Medizinprodukte-Betreiberverordnung" [Medical Device Operator Ordinance]. This ordinance applies to the installation, operation, use and maintenance of medical devices according to § 3 of the German Medical Devices Act (Medizinproduktegesetz) with the exception of medical devices for clinical investigation or performance evaluation assessment.

Neutraliser

The neutraliser is a citric acid-based (e.g. MEtherm 55) or phosphoric acid-based (e.g. MEtherm 56) acidic medium which can be added to the subsequent rinse water in automatic reprocessing after an alkaline cleaning in order to neutralise the alkalinity in order to assist in the removal of the cleaning agent.

pH Value

The pH value is a measure of the strength of the acid or alkali effect of a watery solution.

Process agent

A process agent is a composition of chemical compounds for designed for reprocessing purposes e.g. of medical instruments. Process agents used in a washer-disinfector consist of a cleaning agent, neutraliser and rinse aid.

Qualified electrician

The qualified electrician has the suitable technical training, knowledge, and experience to recognise and avoid hazards that can be caused by electricity, see IEC 60050 or for Germany VDE 0105-100.

Reprocessing

Reprocessing is a measure to prepare a new or used healthcare device for its intended purpose. Reprocessing includes cleaning, disinfection, sterilization and similar procedures.

Rinse aid

The rinse aid (e.g. MEtherm 61) is a mixture of chemical substances which can be added to the last subsequent rinse water used in an automatic reprocessing process to achieve better and quicker drying. The active agents contained in the subsequent rinse agent reduce the surface tension of the subsequent rinse water, thereby minimising the adherent residual moisture.

Rinse liquor

The rinse liquor is a quantity of liquid, which is formed by a quantity of water (preferably, e.g. fresh water, clean water or wastewater) with added process agent. These various types of quantities of water are used in different, specific program steps (e.g. precleaning, cleaning or intermediate rinsing). Depending on the program step, the rinse liquor can be formed by a certain quantity of water with or without process agent.

RKI

RKI is the abbreviation for "Robert Koch-Institut" [Robert Koch Institute]. The Robert Koch Institute is the central institution for the detection, prevention, and control of diseases, especially infectious diseases.

TCP

TCP (Transmission Control Protocol) designates a standard-protocol for a connection between computers and networks.

VRP

VRP is the abbreviation for "Process-Relevant Parameters" (in German: Verfahrensrelevante-Parameter). Process-relevant parameters (e.g. pressure, metered quantity, water level, temperature, time) determined the behaviour of the system (reprocessing result) depending on the selected parameter.



MELAG Medizintechnik GmbH & Co. KG

Geneststr. 6-10

D-10829 Berlin

Germany

Email: info@melag.com

Web: www.melag.com

Original instructions

Responsible for content: MELAG Medizintechnik GmbH & Co. KG

We reserve the right to technical alterations