

# User manual

## Vacuclave® 550

Steam sterilizer

from software version 4.0.1



EN

Dear customer,

We thank you for your confidence demonstrated by the purchase of this MELAG product. As an owner-run and operated family concern founded in 1951, we have a long history of successful specialization in hygiene products for practice-based use. Our focus on innovation, quality and the highest standards of operational reliability has established MELAG as the world's leading manufacturer in the instrument reprocessing and hygiene field.

You, our customer are justified in your demand for the best products, quality and reliability. Providing **“competence in hygiene”** and **“Quality – made in Germany”**, we guarantee that these demands will be met. Our certified quality management system is subject to close monitoring: one instrument to this end is our annual multi-day audit conducted in accordance with EN ISO 13485. This guarantees that all MELAG products are manufactured and tested in accordance with strict quality criteria.

The MELAG management and team.

CE 0197



# Contents

<b>1 General guidelines .....</b>	<b>5</b>	Network bandwidth/Quality of Service (QoS) .....	25
Symbols used .....	5	<b>6 Setup and installation .....</b>	<b>26</b>
Formatting rules .....	5	Record of installation .....	26
Disposal .....	5	Unpacking the device .....	26
<b>2 Safety .....</b>	<b>6</b>	Connecting the power cable and removing the chamber contents .....	27
<b>3 Performance specifications .....</b>	<b>7</b>	Installation examples .....	28
Intended use .....	7	Example 1 - Automatic water supply and disposal with reverse osmosis unit MELAdem 47 (HD) .....	28
Sterilization procedure .....	7	Example 2 - Automatic water supply and disposal with ion exchanger MELAdem 53/53 C (HD) .....	30
Type of the feed water supply .....	7	Example 3 - Automatic water supply and disposal with ion exchanger MELAdem 53/53 C (EA) .....	32
Program runs .....	8	Example 4 - Use of the filling pump with external storage and wastewater container .....	34
Safety equipment .....	9	Connecting the device to the wastewater .....	35
Performance characteristics of reprocessing programs .....	9	Direct connection to the wastewater .....	35
<b>4 Description of the device .....</b>	<b>10</b>	Mounting the loading slide .....	36
Scope of delivery .....	10	Aligning the device .....	37
Views of the device .....	11	Turning the device .....	38
Symbols on the device .....	13	Checking the software version .....	38
Service hatch .....	14	Checking water supply and disposal .....	38
Power button .....	15	Checking date and time .....	39
Colour touch display .....	15	Checking the display brightness and volume .....	39
LED status bar .....	17	Test runs .....	39
Menu .....	17	Electrical test in accordance with EN 50678 (VDE 0701) or national standard .....	39
Program run .....	17	Resetting the maintenance counter .....	39
Heat recovery .....	18	Instructing the users .....	40
Load mounts .....	18	Service connection .....	40
Basic mount .....	18	Service settings .....	40
Comfort mount .....	19	<b>7 First steps .....</b>	<b>41</b>
Overview of the loading variants .....	19	Starting up the device .....	41
Inserting and removing the mount .....	19	Opening and closing the door .....	41
Loading slide .....	20	Opening the door .....	41
<b>5 Installation requirements .....</b>	<b>21</b>	Closing the door .....	42
Installation location .....	21	Manual door emergency opening .....	42
Electromagnetic environments .....	21	Feed water supply .....	43
Space requirements .....	22	Using of a water treatment unit .....	43
Mains connection .....	23	Using an external storage container .....	43
Water connection .....	24	Using the feed water tank (emergency operation) .....	44
System and network safety .....	24	Disposal of the wastewater .....	44
Operating the device with memory media .....	25	<b>8 Important information for routine operation .....</b>	<b>45</b>
Operating the device in the local network (LAN) .....	25		





<b>9 Sterilization</b> .....	<b>46</b>	Water .....	68
Preparing the load .....	46	Administrative settings .....	69
Reprocessing instruments .....	46	Logging on user role .....	69
Reprocessing textiles .....	46	Logging off a user role .....	69
Loading the steam sterilizer .....	47	Users .....	70
Closed sterile containers .....	47	Authentication .....	71
Soft sterilization packaging .....	47	Batch approval .....	71
Multiple wrapping .....	48	Changing the administrator PIN .....	72
Mixed loads .....	48	Software update .....	72
Load quantities .....	48	<b>13 Maintenance</b> .....	<b>73</b>
Selecting the program .....	48	Servicing intervals .....	73
Options .....	50	Checking and oiling the door lock .....	73
Starting the program .....	50	Cleaning .....	74
Aborting the program manually .....	51	Sterilization chamber, door gasket, mount, trays .....	74
Ending the program prematurely .....	52	Housing parts .....	74
Program is ended .....	52	Feed water tank .....	74
Approval process .....	53	Avoiding staining .....	76
Removing the sterile material .....	54	Replacing the sterile filter .....	76
Storing sterile material .....	54	Changing the dust filter .....	77
<b>10 Logging</b> .....	<b>55</b>	Maintenance .....	77
Batch documentation .....	55	<b>14 Pause times</b> .....	<b>78</b>
Output media .....	55	Duration of the operating pause .....	78
Label printer .....	56	Decommissioning .....	78
Displaying logs on the computer .....	56	Transport .....	79
Saving logs .....	57	Symbols on the packaging .....	79
Logs menu .....	57	On-site transport .....	79
Outputting logs .....	58	Off-site transport .....	79
Log output options .....	58	Installing the carrying system .....	80
Printing a label .....	59	<b>15 Malfunctions</b> .....	<b>81</b>
<b>11 Function checks</b> .....	<b>61</b>	Malfunction logs .....	81
Service programs .....	61	Warning and malfunction messages .....	82
Vacuum test .....	61	<b>16 Technical data</b> .....	<b>90</b>
Bowie & Dick test .....	63	<b>17 Components, accessories and spare parts</b> .....	<b>92</b>
Draining .....	63	<b>18 Technical tables</b> .....	<b>94</b>
<b>12 Settings</b> .....	<b>64</b>	Feed water quality .....	94
General settings .....	64	Precision and drift behaviour .....	94
Language .....	64	Sensors .....	94
Date and time .....	64	Measuring chains .....	94
Display brightness .....	65	After 1 year .....	95
Volume .....	65	After 5 years .....	95
Energy-saving .....	66	Nominal value tolerances .....	95
Program options .....	66	Pressure-time chart .....	97
Log output .....	67	Empty chamber test .....	98
Network .....	67	<b>Glossary</b> .....	<b>99</b>
Label print .....	68		

# 1 General guidelines

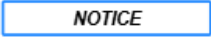

Please read this user manual carefully before commissioning the device. The manual includes important safety instructions. Make sure that you always have access to digital or printed version of the user manual.

Should the manual no longer be legible, is damaged or has been lost, you can download a new copy from MELAG download centre at [www.melag.com](http://www.melag.com).

## Symbols used

Symbol	Description
	Indicates a dangerous situation, which if not avoided, could entail slight to life-threatening injuries.
	Indicates a dangerous situation, which if not avoided, could entail slight to moderate injuries.
	Indicates a dangerous situation, which if not avoided, could result in damage to the instruments, the practice fittings or the device.
	Draws your attention to important information.
	Indicates the section in the document that contains content relevant for the service technician.

## Formatting rules

Example	Description
see <b>Chapter 2</b>	Reference to another text section within this document.
Log	Words or phrases appearing on the display of the device are marked as display text.
	Prerequisites for the following handling instruction.
	Reference to the glossary or another text section.
	Information for safe handling.

## Disposal

MELAG devices are synonymous with long-term quality. When you eventually need to decommission your MELAG device, the required disposal of the device can be carried out by MELAG in Berlin. Simply contact your stockist.

Dispose of ▶components, spare parts, ▶accessories, ▶equipment and consumables that you no longer need properly. Comply with all relevant disposal regulations regarding potentially contaminated waste.

The packaging protects the device against transport damage. The packaging materials have been selected for their environmentally-friendly and recycling properties and can be recycled. Returning the packaging to the material cycle reduces the amount of waste and saves raw materials.

MELAG draws the operator's attention to the fact that they are responsible for deleting personal data on the device to be disposed of.

MELAG draws the operator's attention to the fact that they may be legally obliged (e.g. in Germany according to ElektroG) to remove used batteries and accumulators non-destructively before handing over the device, provided they are not enclosed in the device.

## 2 Safety

---



When operating the device, comply with the following safety instructions as well as those contained in subsequent chapters. Use the device only for the purpose specified in these instructions. Failure to comply with the safety instructions can result in injury and/or damage to the device.

### Qualified personnel

- As with the preceding instrument reprocessing, only [▶competent personnel](#) should undertake sterilization using this steam sterilizer.
- The operator must ensure that the users are regularly trained in the operation and safe handling of the device.

### Power cable and power plug

- Only the power cable included in the scope of delivery may be connected to the device.
- The power cable may only be replaced by an original spare part from MELAG.
- Comply with all legal requirements and locally-specified connection conditions.
- Never operate the device if the plug or power cable are damaged.
- The power cable or plug should only be replaced by [▶authorised technicians](#).
- Never damage or alter the power plug or cable.
- Never bend or twist the power cable excessively.
- Never unplug by pulling on the power cable. Always take a grip on the plug.
- Never place any heavy objects on the power cable.
- Ensure that the power cable does not become jammed in.
- Never lead the cable along a source of heat.
- Never fix the power cable with sharp objects.
- The mains socket must be freely accessible after installation so that the device can be disconnected from the electrical mains at any time if necessary by pulling the mains plug.

### Normal operation

- The door area as well as the cooler and safety valves at the rear of the device may become hot during operation and remain hot for an extended period after switching off.

### Opening the housing

- Never open the device housing. Incorrect opening and repair can compromise electrical safety and pose a danger to the user. The device may only be opened by an [▶authorised technician](#) who must be a [▶qualified electrician](#).

### Notification requirement in the event of serious incidents in the European Economic Area

- Please note that all serious incidents that occur in relation to a [▶medical device](#) (e.g. death or a serious deterioration in a patient's state of health), which were presumably caused by the device must be reported to the manufacturer (MELAG) and the competent authority of the member state in which the user and/or the patient resides.

## 3 Performance specifications

---

### Intended use

The Vacuclave 550 steam sterilizer is mainly intended for use in the medical sector, e.g. in medical and dental practices. The small steam sterilizer is designed according to ▶EN 13060. It uses the fractionated vacuum process to ensure effective steam penetration of the load with saturated steam. It is suitable for ▶reprocessing instruments and materials that may come into contact with blood or body fluids during treatment. The steam sterilizer is not intended for use on patients or in patient environment or for the sterilization of liquids. Typical user groups are doctors, skilled medical personnel and service technicians.

#### **▲ WARNING**

#### **Warning of material damage and injury**

Any attempt to sterilize fluids can result in a ▶delay in boiling. This can cause damage to the device and/or scalding.

- Never use this device to sterilize fluids. It is not licensed for the sterilization of fluids.

### Sterilization procedure

The steam sterilizer sterilizes on the basis of the ▶fractionated vacuum procedure. This guarantees the complete and effective wetting or penetration of the load with saturated steam.

The steam sterilizer uses double jacket technology to generate the sterilization steam, i.e. the steam sterilizer is fitted with a separate steam generator combined with a double-walled sterilization chamber. After heating, steam is held constantly available in the double jacket. This gives the walls of the sterilization chamber a defined temperature and protects the chamber itself from overheating.

This procedure supports the quick ▶evacuation of the air from the sterilization chamber, the sterilization packages and instrument cavities. This allows you to sterilize large quantities of instruments or textiles in a very short time and achieve very good drying results.

### Type of the feed water supply

The device works with a feed water one-way system. It uses fresh ▶feed water in the form of ▶demineralised or ▶distilled water for each sterilization procedure. The quality of the feed water is subject to permanent monitoring via integrated ▶conductivity measurement. If combined with a proper preparation of the instruments, this serves largely to prevent stain accretion on the instruments and soiling of the device.

## Program runs

A reprocessing program runs in three main phases: the air removal and heating up phase, the sterilization phase and the drying phase. After program start, you can follow the program run on the display. It shows the chamber temperature and pressure as well as the time until the end of drying.

### Program phases of a standard reprocessing program

Program phase	Description
1. Air removal and heating up phase	<b>Air removal</b> The air removal phase comprises the conditioning and the fractionating phase. During conditioning, steam is repeatedly injected into and removed from the <a href="#">sterilization chamber</a> . This generates over-pressure and the residual air is removed. Then, during fractionation, the mixture of air and steam is evacuated from the sterilization chamber and steam is injected. This method is also called the fractionated vacuum procedure.
	<b>Heating</b> The continued steam injection into the sterilization chamber leads to an increase in pressure and temperature, which continues until the program-specific sterilization parameters have been reached.
2. Sterilization phase	<b>Sterilizing</b> If the pressure and temperature correspond to the program-dependent nominal values, the sterilization phase begins. The corresponding program parameters (pressure and temperature) are held at sterilization level.
3. Drying phase	<b>Pressure release</b> The sterilization phase is followed by pressure release from the sterilization chamber.
	<b>Drying</b> The sterile material is dried using a vacuum, so-called vacuum drying.
	<b>Ventilation</b> Upon program end, the sterilization chamber is filled with sterile air via the sterile filter and adjusted to the ambient pressure.

### Program phases of the vacuum test

Program phase	Description
1. Evacuation phase	The sterilization chamber is evacuated until the pressure for the vacuum test has been reached.
2. Equilibration time	An equilibration time of 5 min will follow.
3. Measurement time	The measuring time is 10 min. The pressure increase within the sterilization chamber is measured during the measurement time. The evacuation pressure and the equilibration time or measurement time are shown on the display.
4. Ventilation	The sterilization chamber is ventilated after the end of the measuring time.
5. Test end	The display shows the test result, the batch number, the total number of batches and the leakage rate.

## Safety equipment

### Internal process monitoring

A [▶process evaluation system](#) is integrated in the electronics of the device. It compares the process parameters, such as temperature, time and pressure, during a program run. It monitors the parameters in terms of their threshold values and ensures safe and successful reprocessing. A monitoring system checks the device components of the device for their functionality and their plausible interaction. If one or more parameters exceeds pre-determined threshold values, the device issues warning or malfunction messages and if necessary, aborts the program. In the case of a program abort, follow the instructions on the display.

The device works with an electronic parameter control. This serves to optimise the total operating time of a program in dependence on the load.

### Internal logic monitoring

The device's electronics monitor the program run by means of two separate test processes. When a program has been successfully completed, it is shown on the display as a successful program. In addition, the status LED below the display illuminates green.

### Door mechanism

The device constantly checks pressure and temperature in the sterilization chamber and prevents the door from being opened during the program run and when over-pressure has built up. The motor-driven automatic door locking mechanism opens the door slowly by turning the locking spindle. This also holds the door whilst it opens. Even if pressure differences exist, the pressure equalisation takes place until the door is completely open.

### Quantity and quality of the feed water

The quantity and quality of the [▶feed water](#) is automatically checked before every program start.

## Performance characteristics of reprocessing programs

The results in this table show which inspections were performed on the steam sterilizer. The marked fields demonstrate compliance with all the applicable sections of the standard [▶EN 13060](#).

Type tests	Universal-B	Quick-S	Gentle-B	Prion-B
Program type in accordance with <a href="#">▶EN 13060</a>	Type B	Type S	Type B	Type B
<a href="#">▶Dynamic pressure test</a> of the sterilization chamber	X	X	X	X
<a href="#">▶Air leakage</a>	X	X	X	X
<a href="#">▶Empty chamber test</a>	X	X	X	X
<a href="#">▶Solid load</a>	X	X	X	X
<a href="#">▶Porous partial load</a>	X	--	X	X
<a href="#">▶Porous full load</a>	X	--	X	X
<a href="#">▶Simple hollow bodies</a>	X	X	X	X
<a href="#">▶Product with narrow lumen</a>	X	--	X	X
<a href="#">▶Single wrapping</a>	X	--	X	X
<a href="#">▶Multiple wrapping</a>	X	--	X	X
Drying <a href="#">▶solid load</a>	X	X	X	X
Drying <a href="#">▶porous load</a>	X	--	X	X
Sterilization temperature	134 °C	134 °C	121 °C	134 °C
Sterilization pressure	2.1 bar	2.1 bar	1.1 bar	2.1 bar
Plateau period	5:30 min	3:30 min	20:30 min	20:30 min
X = complies with all applicable sections of the standard EN 13060				

## 4 Description of the device

---

### Scope of delivery

Please check the scope of delivery before setting up and connecting the device.

- Vacuclave 550
- User manual
- User manual Accessories for small steam sterilizers
- Manufacturer's inspection report and declaration of conformity
- Warranty certificate
- Record of installation
- 2x Tray lifter
- MELAG USB stick
- Drain hose
- Power cable
- Carrying system
- Allen key for door emergency opening
- Level increase, tank overflow
- Test gauge TR20 for door lock nut
- MELAG oil for door lock nut
- Installation material

For other components that can be used with the device, see --- FEHLENDER LINK ---.

## Views of the device

View from the front

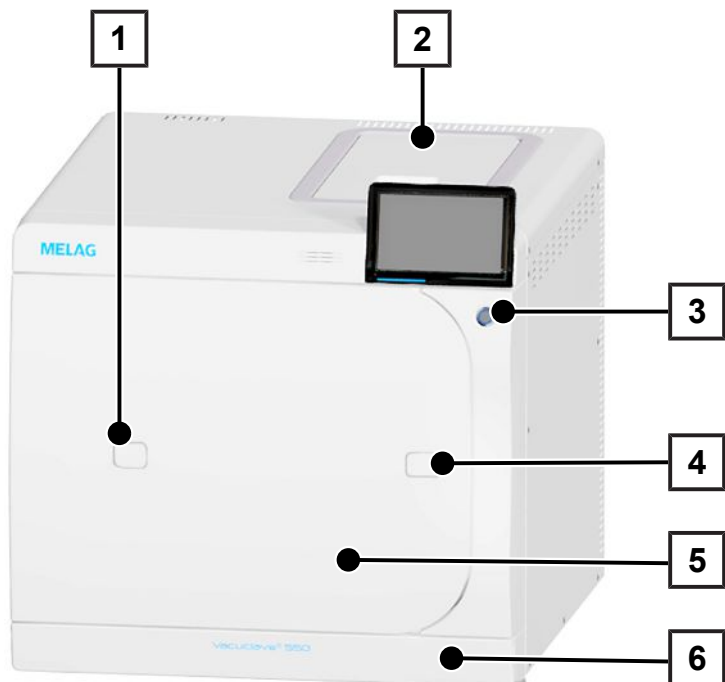

- 1 Access to the validation fitting
- 2 Feed water tank cover
- 3 Power button
- 4 Opening for door opening in an emergency
- 5 Door
- 6 Service hatch

View from the front, with open service hatch

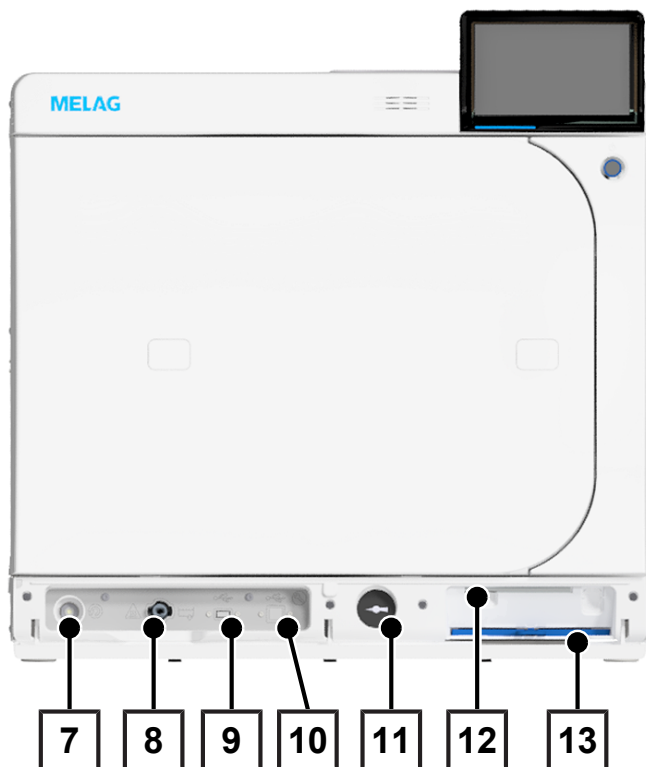

- 7 Overheat protection reset button
- 8 Feed water tank drain valve
- 9 USB port
- 10 Service connection
- 11 Manometer (double jacket steam generator)
- 12 Allen key with which to open the door in an emergency
- 13 Dust filter

*View from the front, with open door*

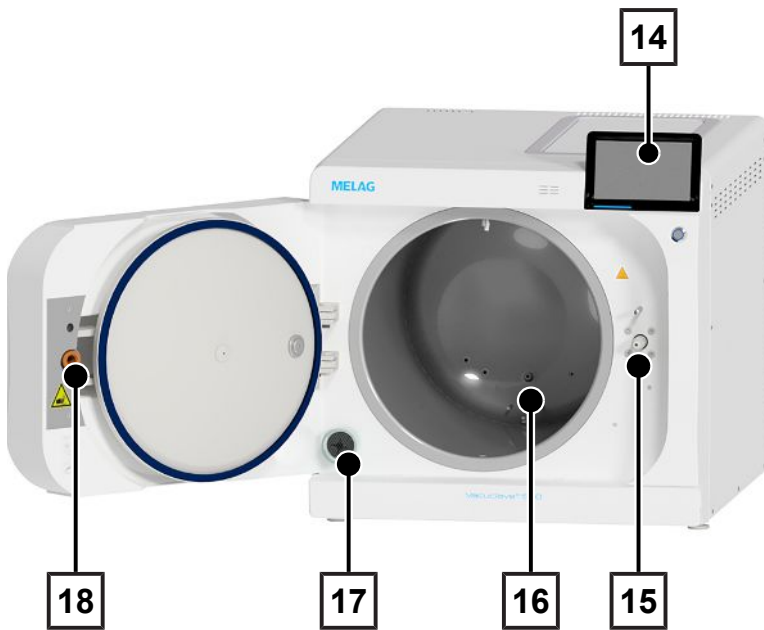

- 14 Colour touch display
- 15 Locking spindle
- 16 Pressure release filter
- 17 Sterile filter
- 18 Lock nut

*View from the rear*

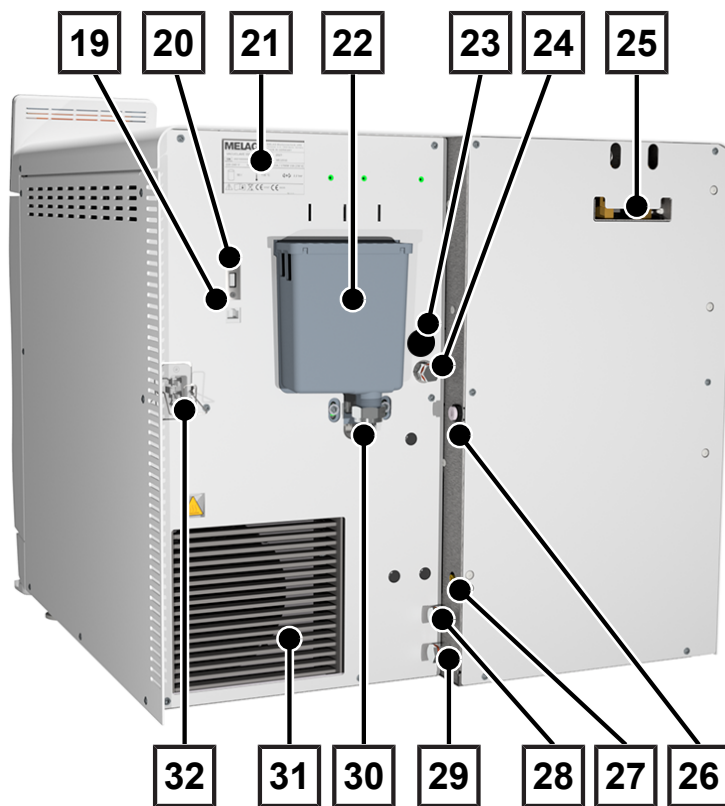

- 19 Ethernet connection
- 20 USB port
- 21 Type plate
- 22 Overflow funnel
- 23 Electrical connection of the filling pump (optional)
- 24 Feed water connection of the filling pump
- 25 Spring loaded safety valves
- 26 Direct drain (optional)
- 27 Connection for level sensor for external wastewater container
- 28 Feed water connection, water treatment unit
- 29 Wastewater connection, water treatment unit
- 30 Wastewater connection
- 31 Cooler
- 32 Power cable connection

*Interior view of feed water tank*

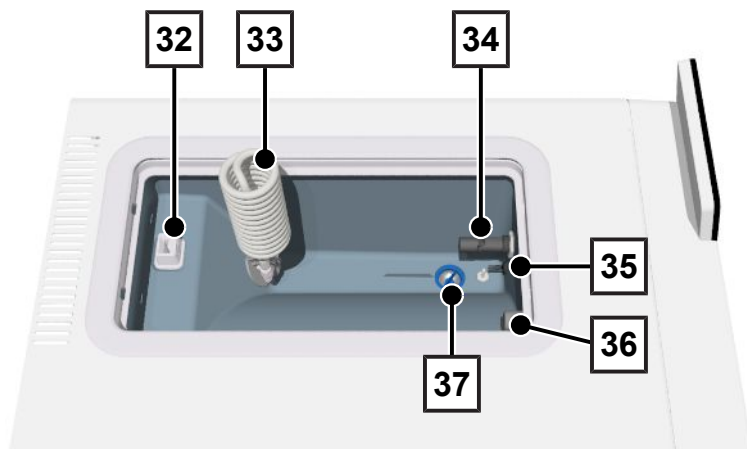

- 32 Level increase, tank overflow
- 33 Heat exchanger
- 34 Float switch
- 35 Conductivity sensor
- 36 Feed water inlet
- 37 Tank filter

**Symbols on the device**

*Type plate*



Manufacturer of the product



Date of manufacture of the product



Label as medical device



Article number of the product



Serial number of the product



Observe user manual or electronic user manual



Do not dispose of product in household waste



CE marking



Identification number of the notified body responsible for conformity assessment according to Pressure Equipment Directive 2014/68/EU



Identification number of the notified body responsible for conformity assessment according to Regulation (EU) 2017/745 on medical devices



Volume of the sterilization chamber



Working overpressure in sterilization chamber



Operating temperature in sterilization chamber



Electrical connection of the product: Alternating current (AC)

**Warning symbols**







The marked area becomes hot during operation. Contact with it during or shortly after operation can pose the danger of burns.







This symbol draws attention to an increased danger of crushing resulting from the improper closure of the door. Comply with the instructions outlined in the corresponding chapter.

**Device symbols - front**

Symbol	Description	Symbol	Description
	Feed water drain connection		Overheat protection reset button
	USB connection		Service connection

**Device symbols - rear**

Symbol	Description	Symbol	Description
<b>De-ionised water</b> 	Feed water connection, water treatment unit	<b>Osmosis drain</b> 	Wastewater connection, water treatment unit
<b>De-ionised water pump</b> 	Feed water connection of the filling pump	<b>Sensor drain</b> 	Sensor of the wastewater container
<b>Pump power</b> 	Electrical connection of the filling pump (optional)	--	--

**Service hatch**

The service hatch is magnetic and is opened by pulling on any side.



## Power button

**PLEASE NOTE**

The device cannot be shut down during a running program.

Press the power button to open the shutdown dialog.

Press the power button again to restart the device.

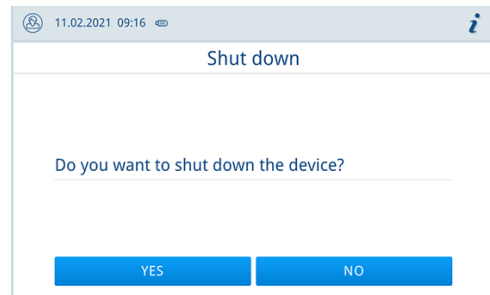

The illumination of the power button indicates the status of the device.

State	Description
illuminated	The device is shut down.
not illuminated	The device is in standby or a program is running.
pulsing	The device is starting up.

## Colour touch display



The user interface consists of a colour 7-inch touch display.

The selected menu item is highlighted in colour.

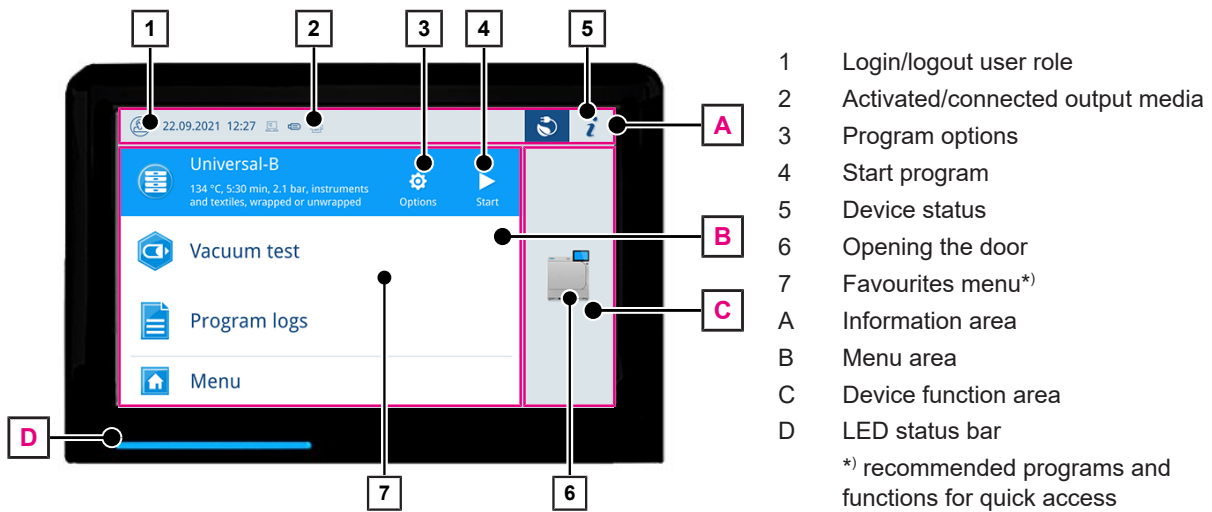



The display of the areas (A, B, C) is dynamic and can change depending on the device status. Due to the dynamic display, the display and position of the buttons on the device may differ from the illustrations shown.







**User role symbols**

Symbol	User role	Description
	Practice employee	Operating the device, making general settings
	Administrator	Operating the device, making administrative settings
	Service technician	Operating the device, making administrative settings and service settings



**Symbols of the output media**

Symbol	Output media	Description
	MELAt race	Output to MELAt race
	FTP	Output to an FTP server
	USB flash drive	Output to a USB stick connected to the USB port
	MELAp rint 60 <sup>1)</sup> /80	Output to a connected label printer

**Buttons in the information area**

Button	Description
	Show or hide <b>Device status</b>
	Malfunction message present Show or hide malfunction message
	Warning message present Show or hide warning message
	Energy-saving activated Show or hide energy-saving dialog

**Buttons in the program selection**

Button	Description
	Starting the program
	Select program options and start program
	Aborting/ending the program

<sup>1)</sup>from model BTP-580II

### LED status bar

The LED status bar on the lowest edge of the display indicates different situations with various colours.

Colour	Description
Blue	Device is in operation, no program active, program running
Green	Program successfully completed, drying in progress
Red	Malfunction message, program abort in progress, program not completed successfully
Yellow	Warning message

### Menu

The **Menu** gives you access to the programs available in the device mode, to various settings and to the log output.

The **Support** menu item contains service contact details and the **License information**.

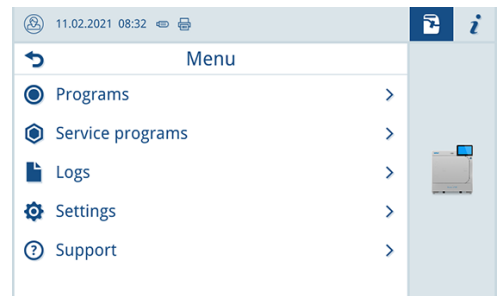

### Program run

During a program run, all important information is shown on the display.

If no input is made on the display, the program display maximises and overlays the menu. Touch the display to show the menu.

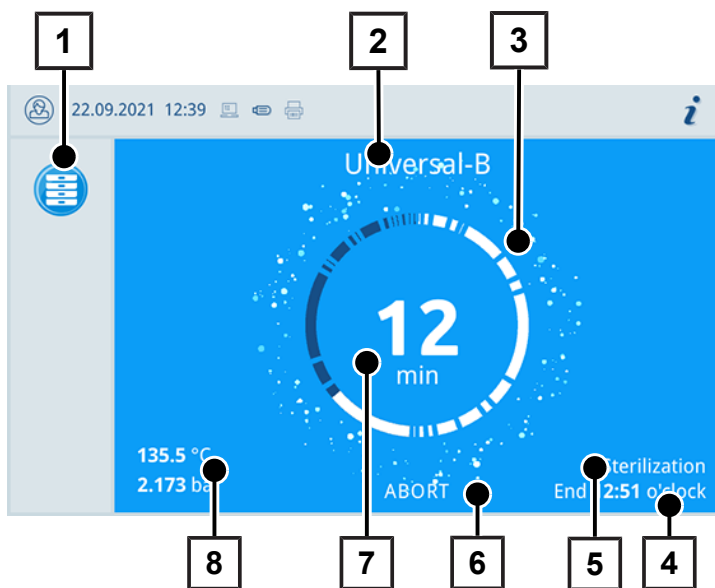

- 1 Running program
- 2 Program name
- 3 Busy indicator
- 4 Estimated end of the program
- 5 Program phase
- 6 Cancel/Exit button
- 7 Remaining run time (remaining program duration)
- 8 Program parameters (temperature/pressure)

The display indicates whether the sterilization phase has been completed successfully. The busy indicator and the LED status bar both change from blue to green as soon as the drying phase is initiated.

## Heat recovery

The **Recovery** symbol indicates active heat recovery.

The heat of the wastewater is used to heat the feed water. This means that the feed water has to be heated less. By recovering this heat, electricity consumption is reduced.

The power recovered through heat recovery is shown in green.

The energy saved over time is displayed in the **Status log**.

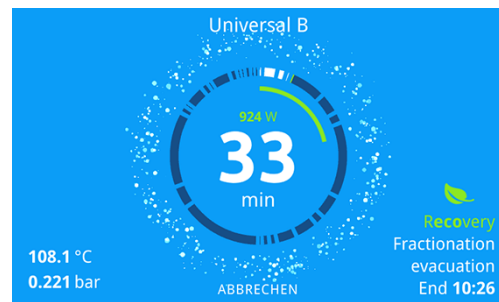

## Load mounts

The mount is used to hold trays, the MELAstore Box or sterilization containers. A mount is not absolutely necessary for the sterilization of sterilization containers or MELAstore Box.

When removing the mount, e.g. for cleaning, first remove all trays and sterilization containers, then the mount itself.

For more information on the articles, see [Components, accessories and spare parts](#) [▶ page 92].

### Basic mount

**NOTICE**

**Warning of material damage from incorrect use**

As the mount has no slide clips, shifting may cause scratches in the sterilization chamber.

- Leave the mount in the sterilization chamber during loading and unloading.

For an overview of the configuration options see [Overview of the loading variants](#) [▶ page 19].

The following illustrations show examples of configuration options:

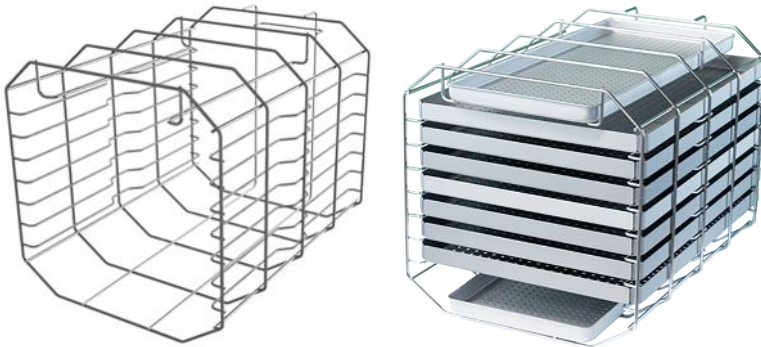

for max. 7 trays (41 x 29 cm) and 2 long trays or  
for max. 14 short trays and 2 long trays

### Comfort mount

**PLEASE NOTE**

The mount can only be used together with the loading slide, see [Loading slide](#) [▶ page 20].

For an overview of the configuration options see [Overview of the loading variants](#) [▶ page 19].

The following illustrations show examples of configuration options:

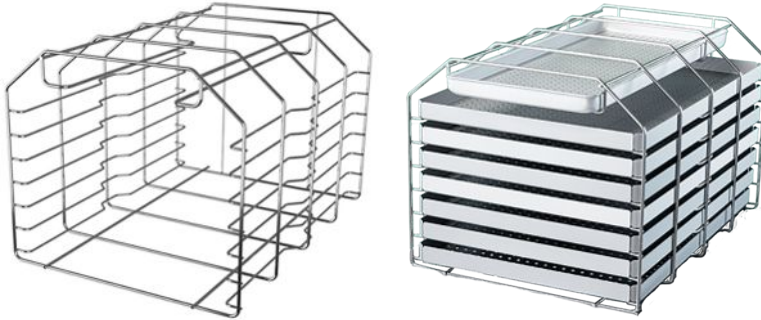

for max. 7 trays (41 x 29 cm) and 1 long tray or  
for max. 14 short trays and 1 long tray

### Overview of the loading variants

In the following overview, you can see which loading variants are possible with the respective mount.

Always adhere to the maximum load quantities, see [Selecting the program](#) [▶ page 48].

	Tray (41 x 29 cm)	Tray		Sterilization container											MELAstore Box	
	short	long		15K	15M	15G	17K	17M	17G	23M	23G	28M	28G	100	200	
Basic mount	7	14	2+14 <sup>2)</sup>	—	—	—	—	—	—	—	—	—	—	—	—	
Comfort mount <sup>1)</sup>	7	14	2+14 <sup>2)</sup>	—	—	—	—	—	—	—	—	—	—	—	—	
Loading slide (without Comfort mount)	—	—	1	10	10	5	10	9	4	4	2	6	3	10	7+1 <sup>3)</sup>	

<sup>1)</sup> Can only be used in combination with the loading slide.

<sup>2)</sup> This mount can additionally accommodate 14 short trays.

<sup>3)</sup> This loading drawer can additionally accommodate a MELAstore Box 100.

### Inserting and removing the mount

The mount has no sliding clips and should **not** be removed from the sterilization chamber regularly.

Note the following when inserting and removing the mount:

- Slide the mount into the sterilization chamber to its fullest extent.
  - ➡ The mount is fixed in the device and remains in the sterilization chamber during loading and unloading.
- To remove the mount, pull it out of the sterilization chamber.

## Loading slide

The loading slide allows convenient loading and unloading of the sterile material. Depending on the load, the slide can be used alone or in combination with the Comfort mount. For an overview of the configuration options see [Overview of the loading variants](#) [▶ page 19].

The slide can be pulled out of the chamber with a tray lifter or heat protection gloves.

The following illustrations show examples of configuration options:

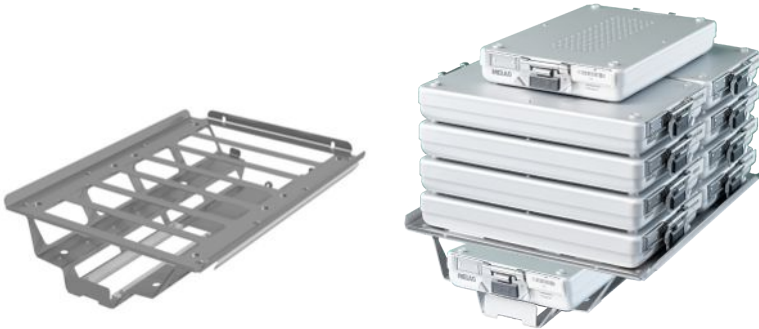

for max. 10 MELAstore Box 100 or for 7 MELAstore Box 200 and 1 MELAstore Box 100

### Loading slide with Comfort mount

The loading slide can be extended with the Comfort mount when the user switches between tray and container loading.



for max. 7 trays (41 x 29 cm) and 2 long trays or for max. 14 short trays and 2 long trays



For max. 7 trays (41 x 29 cm), 1 long tray and 1 MELAstore Box 100 or for 14 short trays, 1 long tray and 1 MELAstore Box 100

### Loading without mounts or loading slide

For loading with containers or MELAstore Box without using the Basic mount or the loading slide, you can position two inverted trays in the sterilization chamber as shown to ensure a better hold.





## 5 Installation requirements

---

**▲ WARNING****Warning of material damage and injury**

Failure to comply with the setup conditions can cause damage to the device and/or injuries.

- The device should only be setup, installed and commissioned by MELAG authorised persons.
- The device is not suitable for operation in explosive atmospheres.
- The device is intended for use outside the patient treatment area. The device should be located a minimum of 1.5 m radius away from the treatment area.

### Installation location

Steam egress can occur during operation. Do not set up the device in the immediate proximity of a smoke detector. Maintain clearance from materials which could suffer damage from steam.

Make sure that the ambient conditions meet the requirements, see [technical data](#) [▶ page 90].

### Electromagnetic environments

When assessing the electromagnetic compatibility (EMC) of this device, the emission limits for Class B devices and the immunity for operation in a basic electromagnetic environment are based on [IEC 61326-1](#). The device is thus suitable for operation in all facilities including those in residential areas and those that are directly connected to a public mains supply that also supplies buildings used for residential purposes. The floor should be made of wood or concrete or be tiled with ceramic tiling. If the floor is fitted with synthetic material, the relative humidity must be at least 30 %. Humidity reduces the development of electrostatic discharges.



Space requirements

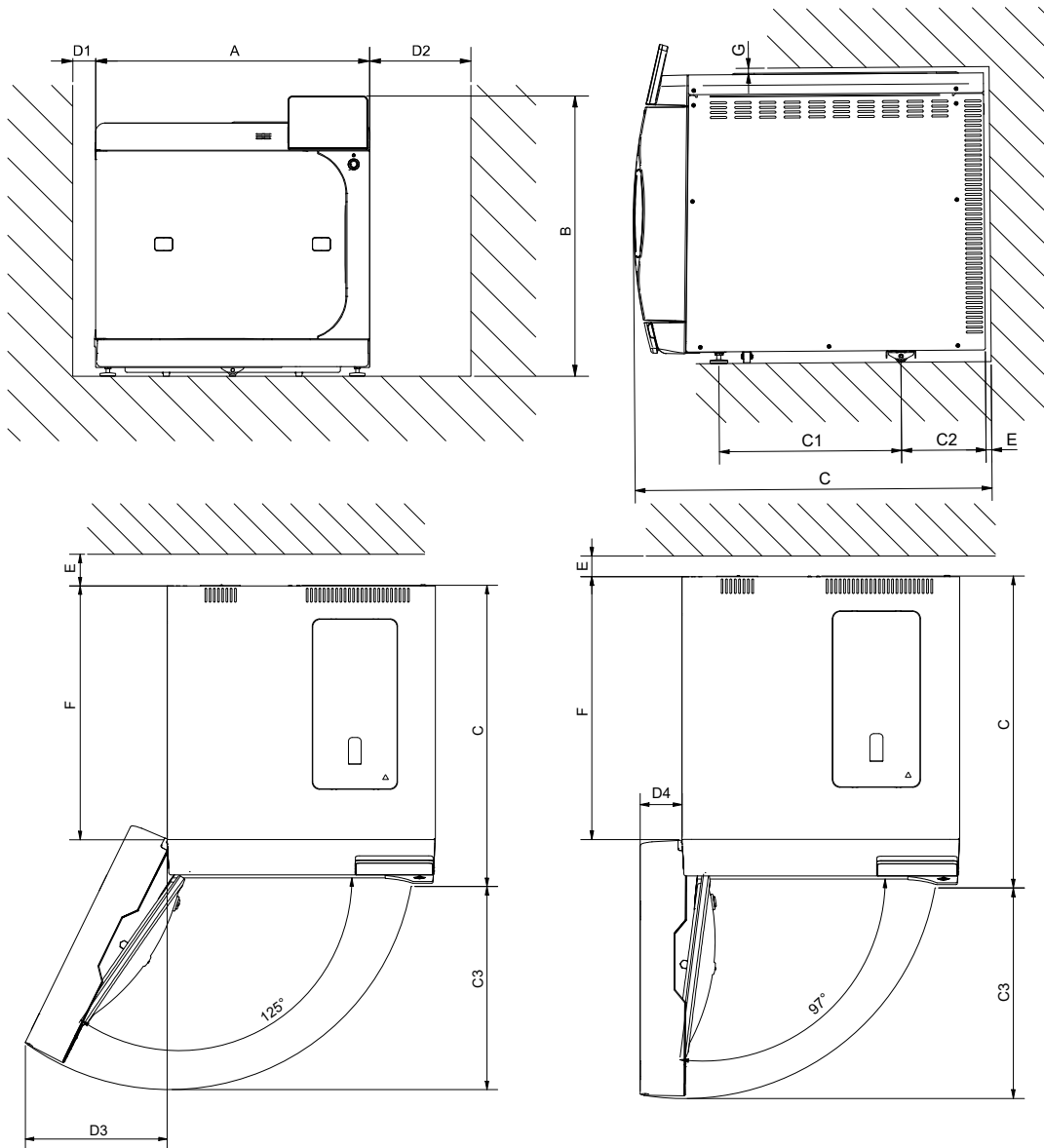

Dimensions		Vacuclave 550
Width	A	63.6 cm
Height	B	65 cm
Depth	C	71.5 cm
Clearance between the device feet	C1	37.1 cm
Clearance from rear device foot up to the rear panel	C2	17.3 cm
Max. swivel distance with open door	C3	48.2 cm
Min. clearance to left side (heat emission)	D1	5 cm
Min. clearance to right side (heat emission)	D2	20 cm
Distance to the door hinge side 125°	D3	34.1 cm
Distance to the door hinge side 97°	D4	9.6 cm
Min. clearance to the rear	E	1 cm
Clearance when door fully open	F	57 cm
Min. clearance to the top	G	1 cm (wall cupboard 60 cm above worktop)



**Additional space requirement for the feed water supply**

If the device is operated with a water treatment unit or filling pump with storage tank, additional space is required. It is necessary to ensure free access to the hoses and cables of the device leading to the water treatment unit.

Dimensions	MELAdem 47	
	Osmosis module	Pressure tank
Height	46 cm	40 cm
Width	40 cm	--
Depth	18 cm	--
Diameter	--	Ø 28 cm

Space is required above the MELAdem 53 / MELAdem 53 C for free access to the hose connections.

Dimensions	MELAdem 53	MELAdem 53 C
Diameter	24 cm (26 cm incl. water inlet hose)	24 cm (26 cm incl. water inlet hose)
Height of the unit incl. connecting parts	57 cm (approx. 62 cm incl. connection kit)	45 cm (approx. 49.5 cm incl. connection kit)

**Requirements for incorporating the device**

If the incorporation of the device is absolutely necessary, ensure that the device can be removed for maintenance and operation (pos. a). In addition, implement one of the following measures:

- In the installation space, there must be an exhaust shaft in the rear area that discharges the warm air upwards (pos. b).
- There must be an exhaust shaft in the rear area of the installation space that actively discharges the warm air to the rear (pos. c).

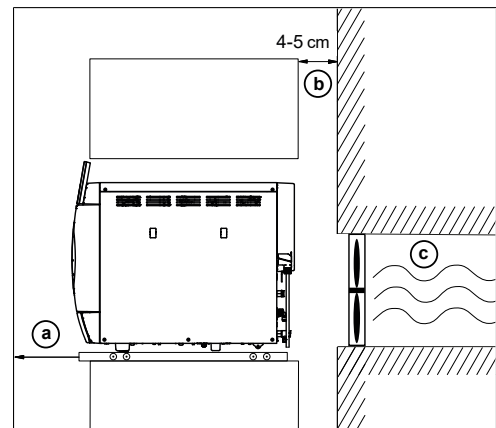

**Mains connection**

Make sure that the electrical connection meets the requirements on site, see [Technical data](#) [▶ page 90].



## Water connection

	Feed water	Wastewater
Connection in the practice	<ul style="list-style-type: none"> <li>water treatment unit, e.g. MELAdem 47</li> <li>optional: external storage container</li> </ul>	<ul style="list-style-type: none"> <li>wall outlet (nominal diameter DN 40) or U-trap (flush outflow)</li> <li>optional: manual disposal via the external wastewater container</li> </ul>
Installation height	--	min. 30 cm below the device
Measures for protecting the drinking water	<p>The device has an internal free fall section (safety combination AB) to protect the drinking water.</p> <p>To protect the MELAdem 47, MELAdem 53 and MELAdem 53 C water treatment units, MELAG recommends the installation of a safety combination according to EN 1717.</p> <p>Further country specific measures may be required for protecting the drinking water.</p>	

### Connection of a water treatment unit

	MELAdem 47	MELAdem 53/53 C
Permissible hydraulic pressure	2-6 bar	1.5-10 bar
Water stop	It is necessary to install a water stop with shut-off valve for the connection of a water treatment unit.	

## System and network safety

The device is fitted with multiple external interfaces. Comply with the following information pertaining to the use of these interfaces to ensure safe operation of the device, especially to ensure incorporation in the local network (LAN).

### Interfaces and connections

Comply with the following for safe handling:

- Only connect the hardware to the device which is listed in the following table.
- Only use the software which has been intended for the purpose and approved by the manufacturer.
- When performing a device software update, use only the update data authorised by MELAG for the corresponding device type.

Interface	Type	Hardware	Software/purpose
USB	Type-B	USB type-A socket (via USB type-B to type-A cable)	MELAview Service Saving log data, querying device data using diagnostics mode
USB	Type-A	MELAG USB flash drive with FAT32 file system	Saving log data
		MELAG USB flash drive with FAT32 file system and software update container	Device software update
		MELAprint 60/80	Label print
Ethernet	Ethernet IEEE 802.3	Switch port (Practical network)	MELAtrace saving log data, querying device data
			FTP server save log data
			Label printing via MELAprint 60



## Operating the device with memory media

To prevent data loss, only use memory media to save the log data with the following characteristics:

- functional (without malware, etc.)
- writeable
- formatted with a correct file system (FAT32)

Perform regular data backup. Restrict access to the device and systems with access authorisation to the necessary circle of persons.

Only use MELAG USB sticks.

## Operating the device in the local network (LAN)

An Ethernet/IP-based network connection (LAN) is required to operate the device in a local network. In its delivery state, the device is configured to obtain the IP address automatically from a DHCP server operated in a LAN.

Comply with the following for safe handling:

- To avoid security vulnerabilities, do not connect the device to a public network (e.g. the internet).
- Check the IP address carefully during the conversion for a manual configuration before connecting the device to the LAN. An incorrectly-entered IP address can cause IP conflicts in the network and thus disturb another device in your network.

In the LAN with a firewall, only permit connections to and from the device which correspond to the intended use of the device. All ports not used are blocked on the device side.

The device is able to make the following connections as standard:

Log	Source port	Destination port	Direction	Purpose
TCP	63000 - 64000	21	Outgoing	FTP control
TCP	any	63000 - 64000	Listening/ Incoming	FTP (passive) data transfer (device set to FTP logging)
UDP	68	67	Outgoing	Communication to DHCP server - requests to the DHCP server
UDP	67	68	Listening/ Incoming	Answers from DHCP server(s)
TCP	any	3333	Listening/ Incoming	Data transfer log data (device set to TCP logging)
UDP	62000	3000	Outgoing	Broadcast search printer
UDP	3000	62000	Listening/ Incoming	Search answers printer
TCP	≥ 1025	9100	Outgoing	Data transfer to the printer

## Network bandwidth/Quality of Service (QoS)

The device does not place any requirements on the LAN bandwidth for data transfer, that exceed the standard time-out times of the respective logs.

Process	Volume max.	Volume normal
Program log	1 MB	200 kB
Malfunction log	64 kB	10 kB
Status log	64 kB	20 kB
System log	40 MB	--



## 6 Setup and installation

### ⚠ WARNING

#### Warning of material damage and injury

Improper installation can cause a short-circuit, fire, water damage or an electric shock. Serious injuries and/or damage to the device can result.

- The device should only be setup, installed and commissioned by MELAG authorised persons.

Comply with the following for safe handling:

- Do not install or operate the device in potentially explosive areas.
- Install and operate the device in a frost-free environment.
- Have the electrical connection and the water supply and waste water connections installed only by trained personnel.
- For the initial commissioning, observe all instructions described in the user manual.
- Position the device in such a way that the faultless functioning of the spring loaded safety valve is guaranteed. The spring loaded safety valve must be able to move freely and not become stuck or blocked.

### Record of installation

The record of installation must be completed by an [authorised technician](#), as evidence of proper setup, installation and initial commissioning and for warranty claims, and a copy sent to MELAG.

### Unpacking the device

### ⚠ CAUTION

#### Warning of injury

Lifting and carrying the device incorrectly can cause spinal damage, crushing injuries and bruising.

- Carry the device with at least two people.
- Use the carrying system to carry the device.

1. Use the carrying system to lift the device out of the box.
2. Check the device after unpacking for any damage suffered during transport.
3. To remove the carrying system, undo the three bottom housing screws.

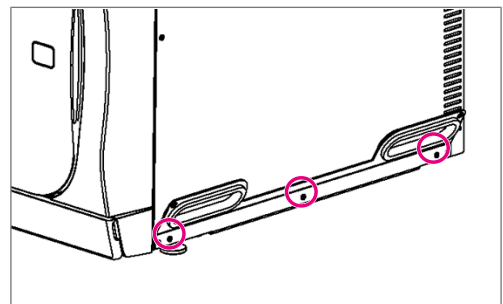



- Unhook the carrying aid from the baseplate from below.

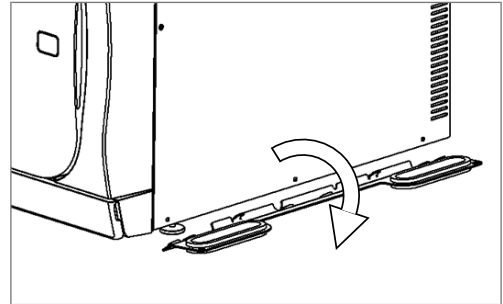

- Tighten the housing screws again.
- Keep the carrying system.

## Connecting the power cable and removing the chamber contents

### NOTICE

#### Warning of material damage from incorrect temperature

Operating the device outside the specified ambient temperature (5-40 °C) can lead to damage to individual device components (e.g. circuit boards, vacuum pump, etc.).

- Allow the device to acclimatise to the required ambient temperature (5-40 °C) before switching it on for the first time.

- Connect the power cable to the rear of the device and fold down the safety latch.

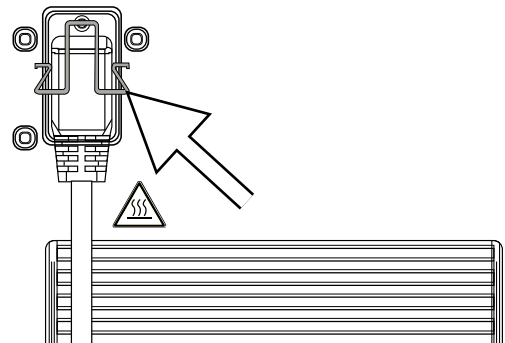

- Connect the device power plug to the mains socket.
- Power up the device by pressing the power button. The start screen appears on the display.
  - After a short waiting time, the favourites menu is displayed.
- Press the **OPEN DOOR** button to open the door.
- Remove all components, accessories and equipment parts from the sterilization chamber.
- Close the door.
- Press the power button to shut down the device.
- Remove the mains plug to disconnect the device from the power supply.



## Installation examples

On the following pages you will find examples for the recommended types of installation for the supply of feed water and the disposal of wastewater.

**PLEASE NOTE**

For detailed information on the cold water connection of the water treatment unit, see the user manual of the unit.

### Example 1 - Automatic water supply and disposal with reverse osmosis unit MELAdem 47 (HD)

Always install an automatic water disposal for an automatic water supply. To do so, use the installation material included in the scope of delivery and the installation set of the water treatment unit. The direct connection of the water treatment unit to the domestic water supply also requires the installation of a water stop.

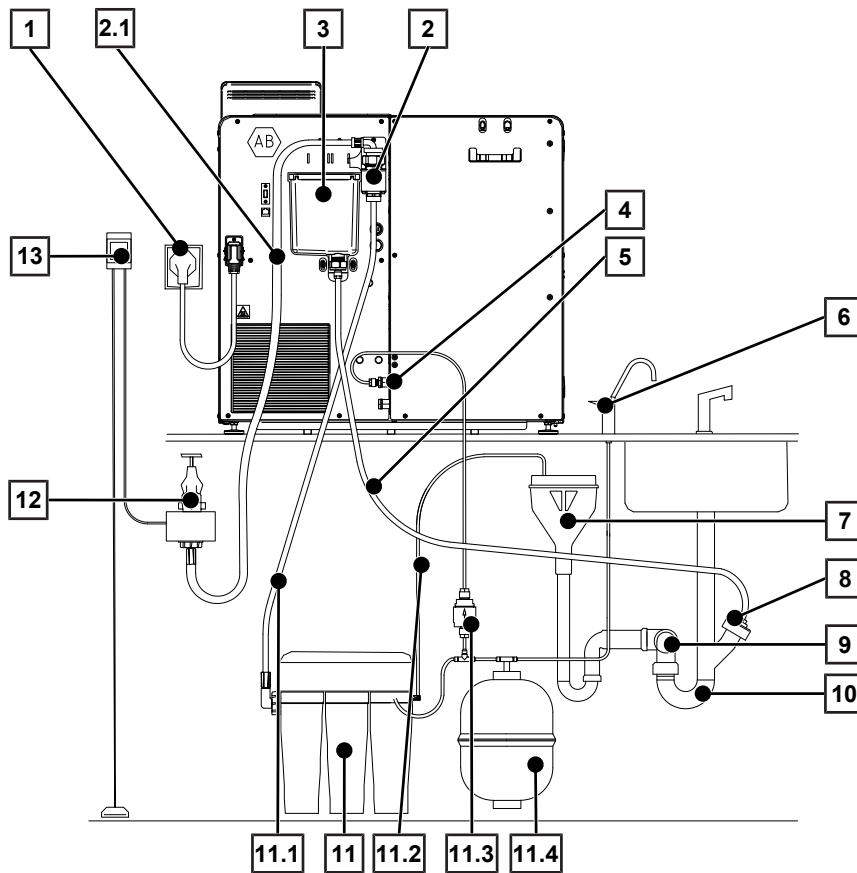

Position	Description	Art. no.	Note
1	Mains connection	--	on-site
2	<b>Safety combination HD with wall mount</b>	ME70686	--
2.1	Water inlet hose EN 1717 (2.5 m)	ME24930	included in ME70686
3	Overflow funnel	--	present on device-side
4	<b>Feed water connection, water treatment unit</b>	--	present on device-side
4.1	Copper seal for 1/4" external thread	ME32050	included in the scope of delivery
4.2	Screw-in fitting 1/4" on hose 6/4 mm	ME53450	included in the scope of delivery



Position	Description	Art. no.	Note
5	PTFE hose, 8/6 mm (2.5 m)	--	included in the scope of delivery
6	Water tap for MELAdem	ME91900	included in ME01047
7	on-site protection (air gap to EN 1717)	--	on-site
<b>8</b>	<b>Double hose nozzle connection</b>	--	--
8.1	Copper seal for 1/4" external thread	ME32050	included in the scope of delivery
8.2	Screw-in fitting 1/4" OT on hose 8/6 mm	ME38710	included in the scope of delivery
8.3	Wastewater adapter (G1/4" internal thread)	ME56930	included in the scope of delivery
9	Wall outlet DN 40	--	on-site
10	Wastewater connection vented to the top (washing machine connection)	--	on-site
<b>11</b>	<b>MELAdem 47 reverse osmosis unit</b>	ME01047	--
11.1	Water inlet hose	ME37220	included in ME01047
11.2	Outlet hose for concentrate	ME37458	included in ME01047
11.3	Filter for MELAdem	ME48240	included in ME01047
11.4	Pressure tank MELAdem 47 (with shut-off valve and hose)	ME57065	included in ME01047
12	Water tap 3/4" with safety combination	--	on-site
13	Water stop (leakage water detector with shut-off valve and probe)	ME01056	--
<b>Optionally available:</b>			
--	PUR hose 6/4 mm (10 m, black)	ME28820	--

**NOTICE**

**Warning of material damage from improper installation**

There is a risk of water damage if the water connection is installed improperly.

- Check all water connections and joints.

1. Connect the outlet hose to the existing U-trap of the building's water system, see [Connection to the wastewater](#) [▶ page 35].
2. Fasten the safety combination HD to the wall. When doing so, pay attention to the flow direction indicated on the safety combination. Observe the minimum distance of the fall section (25 cm) above the following maximum liquid level.  
**PLEASE NOTE:** An EN 1717 compliant installation to the drinking water system requires a water tap with safety combination.
3. Install the water stop.
4. Install the MELAdem 47 as described in the relevant installation instructions.  
**PLEASE NOTE:** Discharge the concentrate of the reverse osmosis unit into a building drain with air gap. The continuous discharge of the concentrate must be ensured by means of a type AA device for separation from the wastewater disposal in accordance with EN 1717.
5. Connect the power cable to the device.
6. Press the power button to switch on the device.
7. Check whether the water supply and disposal is set to **Automatic**, see [Checking the water supply and disposal](#) [▶ page 38].



### Example 2 - Automatic water supply and disposal with ion exchanger MELAdem 53/53 C (HD)

Always install an automatic water disposal for an automatic water supply. To do so, use the installation material included in the scope of delivery and the installation set of the water treatment unit. The direct connection of the water treatment unit to the domestic water supply also requires the installation of a water stop.

The MELAdem 53/53 C water treatment unit is either connected to the device's feed water connection either via a water branch or by means of a water distributor.

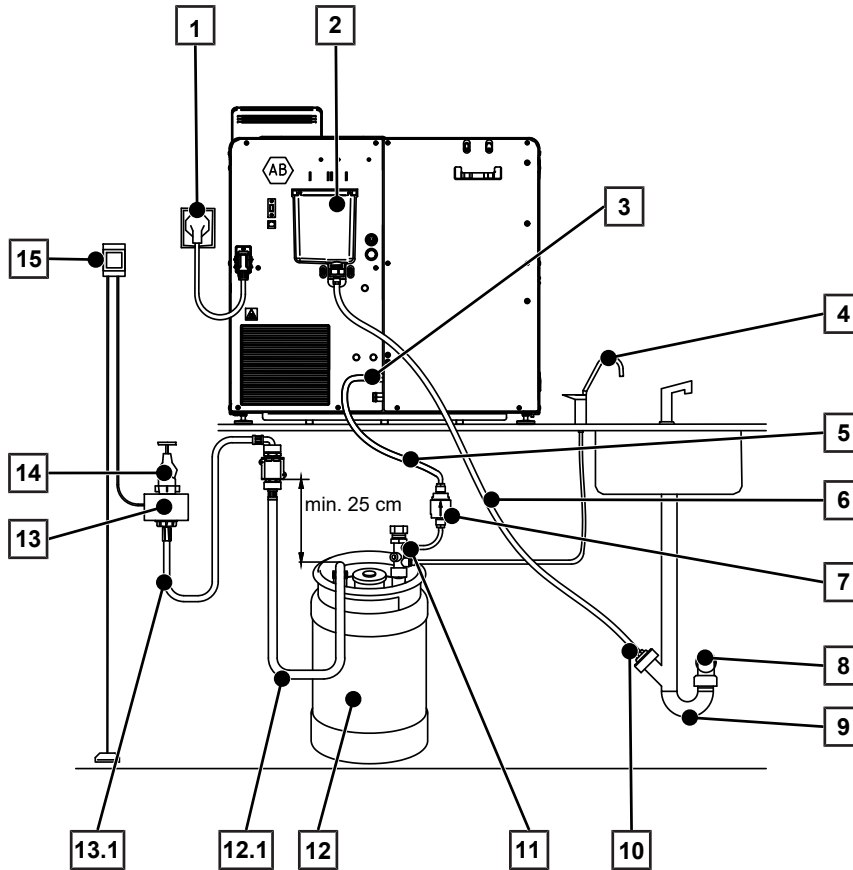

Position	Description	Art. no.	Note
1	Mains connection	--	on-site
2	Overflow funnel	--	present on device-side
<b>3</b>	<b>Feed water connection, water treatment unit</b>	--	--
3.1	Copper seal for 1/4" external thread	ME32050	included in the scope of delivery
3.2	Screw-in fitting 1/4" on hose 6/4 mm	ME53450	included in the scope of delivery
4	Water tap for MELAdem	ME91900	--
5	PUR hose (black) 6/4 mm	--	included in the scope of delivery
6	PTFE hose, 8/6 mm (2.5 m)	--	included in the scope of delivery
7	Filter for MELAdem	ME48240	--
8	Wall outlet DN 40	--	on-site
9	Wastewater connection vented to the top (washing machine connection)	--	on-site



Position	Description	Art. no.	Note
<b>10</b>	<b>Connection to siphon</b>	--	--
10.1	Copper seal for 1/4" external thread	ME32050	included in the scope of delivery
10.2	Screw-in fitting 1/4" OT on hose 8/6 mm	ME38710	included in the scope of delivery
10.3	Wastewater adapter G1/4" internal thread	ME56930	included in the scope of delivery
11	Water distributor for MELAdem 53 for connecting several devices	ME69005	--
<b>12</b>	<b>MELAdem 53/53 C</b>	ME01038/ ME01036	--
12.1	Connection hose (2.5 m)	ME70904	included in ME01038/ ME01036
<b>13</b>	<b>Safety combination HD with wall mount</b>	ME70686	--
13.1	Water inlet hose EN 1717 (2.5 m)	ME24930	included in ME70686
14	Water tap 3/4" with safety combination	--	on-site
15	Water stop (leakage water detector with shut-off valve and probe)	ME01056	--

**NOTICE**

**Warning of material damage from improper installation**

There is a risk of water damage if the water connection is installed improperly.

- Check all water connections and joints.

1. Connect the outlet hose to the existing U-trap of the building's water system, see [Connection to the wastewater](#) [▶ page 35].
2. Fasten the safety combination HD to the wall. When doing so, pay attention to the flow direction indicated on the safety combination. Observe the minimum distance of the fall section (25 cm) above the following maximum liquid level.  
**PLEASE NOTE:** An EN 1717 compliant installation to the drinking water system requires a water tap with safety combination.
3. Install the water stop.
4. Install the MELAdem 53/53 C as described in the relevant installation instructions.  
**PLEASE NOTE:** Discharge the concentrate of the reverse osmosis unit into a building drain with air gap. The continuous discharge of the concentrate must be ensured by means of a type AA device for separation from the wastewater disposal in accordance with EN 1717.
5. Connect the power cable to the device.
6. Press the power button to switch on the device.
7. Check whether the water supply and disposal is set to **Automatic**, see [Checking the water supply and disposal](#) [▶ page 38].





Position	Description	Art. no.	Note
<b>9</b>	<b>Connection to siphon</b>	--	--
9.1	Copper seal for 1/4" external thread	ME32050	included in the scope of delivery
9.2	Screw-in fitting 1/4" OT on hose 8/6 mm	ME38710	included in the scope of delivery
9.3	Wastewater adapter G1/4" internal thread	ME56930	included in the scope of delivery
10	Water distributor for MELAdem 53 for connecting several devices	ME69005	--
<b>11</b>	<b>MELAdem 53/53 C</b>	ME01038/ ME01036	--
11.1	Connection hose (2.5 m)	ME70904	included in ME01038/ ME01036
12	Non return (check) valve type EA	ME75300	--
13	Water tap 3/4" with safety combination	--	on-site
14	Water stop (leakage water detector with shut-off valve and probe)	ME01056	--

**NOTICE**

**Warning of material damage from improper installation**

There is a risk of water damage if the water connection is installed improperly.

- Check all water connections and joints.

1. Connect the outlet hose to the existing U-trap of the building's water system, see [Connection to the wastewater](#) [▶ page 35].
2. Fasten the safety combination HD to the wall. When doing so, pay attention to the flow direction indicated on the safety combination. Observe the minimum distance of the fall section (25 cm) above the following maximum liquid level.  
**PLEASE NOTE:** An EN 1717 compliant installation to the drinking water system requires a water tap with safety combination.
3. Install the water stop.
4. Install the MELAdem 53/53 C as described in the relevant installation instructions.  
**PLEASE NOTE:** Discharge the concentrate of the reverse osmosis unit into a building drain with air gap. The continuous discharge of the concentrate must be ensured by means of a type AA device for separation from the wastewater disposal in accordance with EN 1717.
5. Connect the power cable to the device.
6. Press the power button to switch on the device.
7. Check whether the water supply and disposal is set to **Automatic**, see [Checking the water supply and disposal](#) [▶ page 38].



### Example 4 - Use of the filling pump with external storage and wastewater container

The device is supplied with feed water from the storage container via the filling pump. The maximum suction lift is 1.2 m. The wastewater is fed into the wastewater container via the drain hose. The filling level of the wastewater container is monitored by the device with a level sensor.

**PLEASE NOTE** Note the separate instructions for installation of the filling pump (doc. ZBA\_P10).

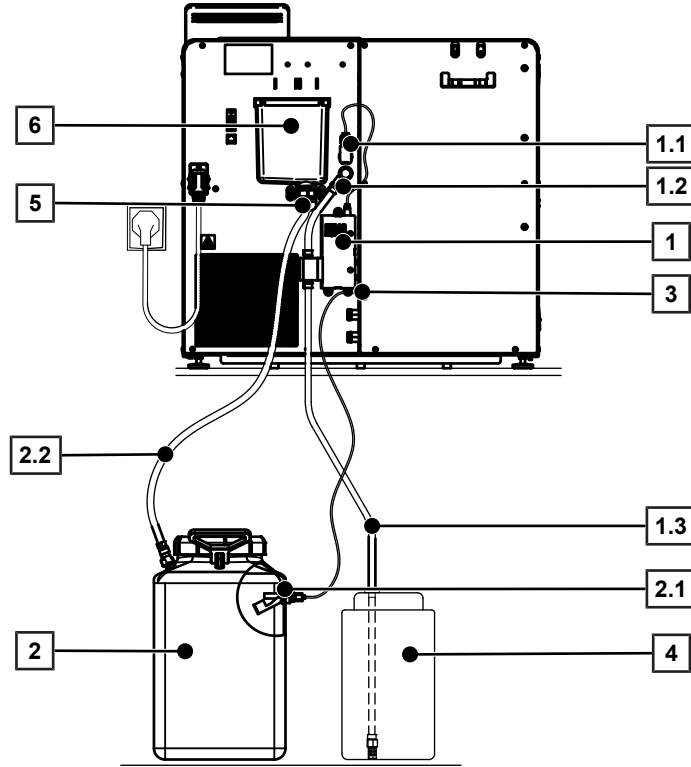

Position	Description	Art. no.	Note
1	Filling pump	ME65010	--
1.1	Electrical connection of the filling pump	--	present on device-side
1.2	Inlet hose	--	included in ME65010
1.3	Suction hose with suction hose storage container	--	included in ME65010
2	<b>Wastewater container</b>	ME65020	--
2.1	Sensor for external wastewater container	--	included in ME65020
2.2	Wastewater container outlet hose	--	included in ME65020
3	Connection for sensor for external wastewater container	--	present on device-side
4	Storage container for feed water	--	--
5	Wastewater connection	--	present on device-side
6	Overflow funnel	--	present on device-side



**NOTICE**

**Warning of material damage from improper installation**

There is a risk of water damage if the water connection is installed improperly.

- Check all water connections and joints.

1. Connect the outlet hose to the external wastewater container (doc. ZBA\_ABW).
2. Install the filling pump as described in the separate installation instructions (doc. ZBA\_P10).
3. Connect the power cable to the device.
4. Press the power button to switch on the device.
5. In the **Settings > Water** menu, set the wastewater disposal to **Manual**, see [Water](#) [▶ page 68].

**Connecting the device to the wastewater**

To ensure safe operation of the device, the wastewater must be able to flow freely and unobstructed to the wall outlet. Comply with the following:

- The outlet hose should be kept as short as possible (maximum 2.5 m).
- The outlet hose must be laid with a continuous fall and kink-free.
- The wall outlet should be located at least 30 cm under the device.
- The U-trap used must be ventilated (not a double-chamber U-trap)

1. Cut the outlet hose supplied (PTFE hose) to the required length.
2. Depending on the installation variant, connect the overflow funnel to the existing U-trap or to the external wastewater container, see [Installation examples](#) [▶ page 28].
3. Perform a drain test, see [Test runs](#) [▶ page 39].

**Direct connection to the wastewater**

If one of the requirements for the wastewater connection cannot be met or a display message indicates poorly discharging wastewater (e.g. message 10101; see [Malfunctions](#) [▶ page 81]), you can connect the steam sterilizer directly to the wastewater.

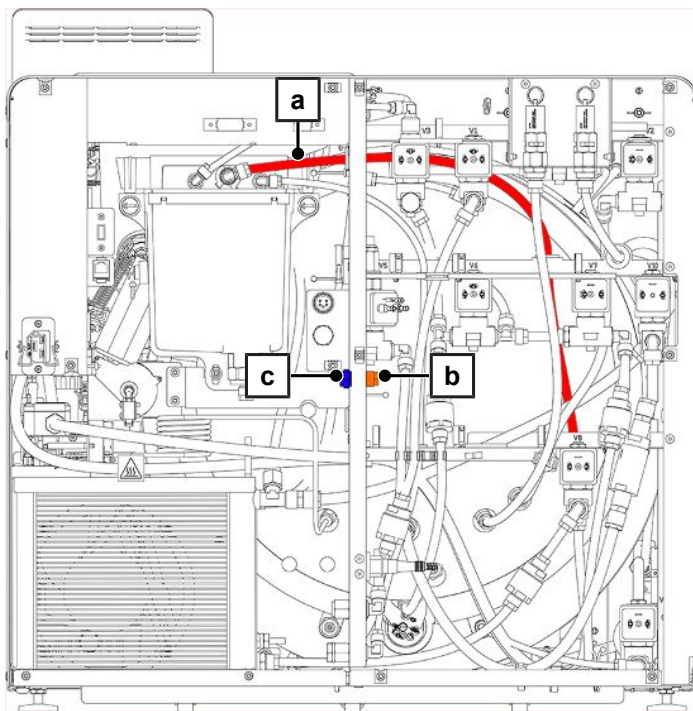



Description	Art. no.
Wastewater via pressure release conversion set	ME09044
Double-chamber siphon*)	ME26635
*) recommended for noise insulation, if not already available on site	

1. Undo the screws (TX20) in the rear device cover and remove the cover.
2. Dismantle the wastewater hose (pos. a) from the overflow funnel.
3. Shorten the wastewater hose and use the internal connection socket to connect it to the direct outlet (pos. b).
4. Remove the external screw plug of the direct outlet (pos. c) to the opposite side.
5. Connect the direct outlet to the buildings' wastewater connection. To do so, use the material from the table.
6. Mount the rear device cover.
7. Connect the overflow funnel to the wastewater, see [Connecting the device to the wastewater](#) [▶ page 35].

### Mounting the loading slide

1. Place the fixing plate (pos. a) from behind into the loading slide (pos. b).

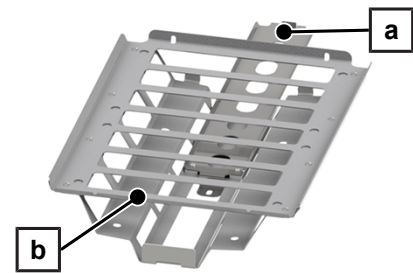

2. Fold the sliding film on the loading slide down.

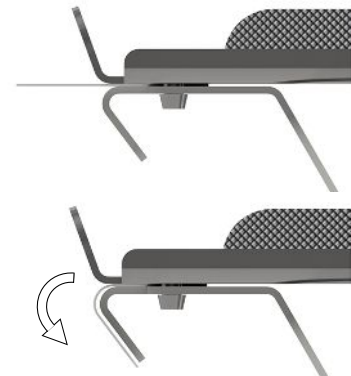

3. **NOTICE! Warning of material damage. A misaligned sliding film can cause scratches in the sterilization chamber. Make sure the sliding film remains folded down.**

Place the loading slide together with the fixing plate in the sterilization chamber.

4. Align the fixing plate so that the thread of the pressure release filter protrudes through the rear lug of the fixing plate.

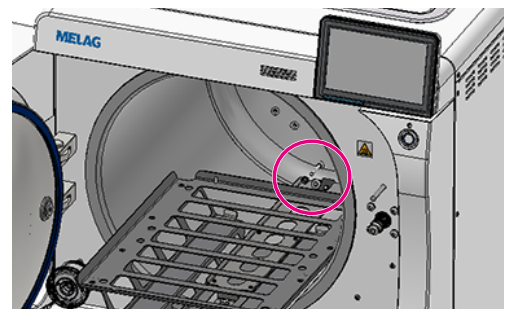

5. Pull the loading slide out slightly to better access the pressure release filter (pos. c).



6. Mount the loading slide to the rear of the pressure release filter using a locking edge washer and the hex nut.

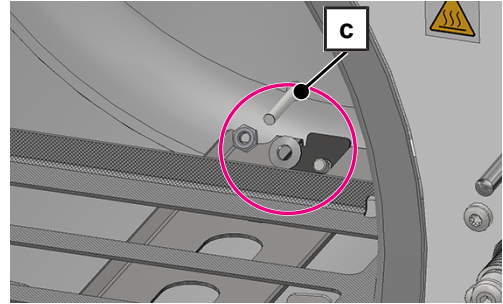

7. Slide the loading slide fully into the device.

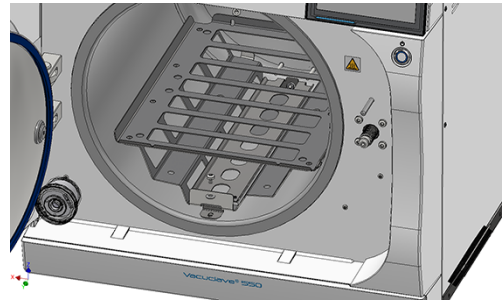

8. Mount the loading slide at the front with a locking edge washer and flat-head screw.

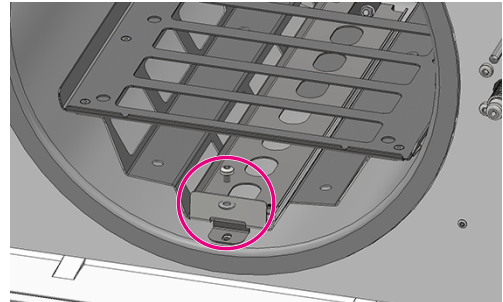

9. If the loading slide is difficult to move after assembly, check the sliding ability again after the test run in the **Universal-B** program.

**PLEASE NOTE**

If the loading slide is still difficult to move even after the trial run, the contact for of the fixing plate on the loading slide is too high.

- Dismantle the loading slide and unscrew the pressure release filter by half a turn or one turn.

**Aligning the device**

For fault-free operation, the device must be aligned, so that the condensate from the sterilization chamber can drain.

1. Unscrew the two device feet (approx. 1 cm).
2. Position a spirit level on the top cover plate and align the device horizontally.
3. Fix the feet of the device with the lock nut (AF 13).



## Turning the device

To make it easier to reach the components installed on the device sides when working (e.g. maintenance), the device can be turned as follows.

1. Close the door so that it does not swing open unintentionally.
2. Switch off the device.
3. Remove the power cable.
4. Remove the outlet hose on the drain side and, if applicable, any other connections.
5. Lift the device slightly and carefully pull it forward on the worktop until the two front device feet (pos. a) are no longer on the worktop.

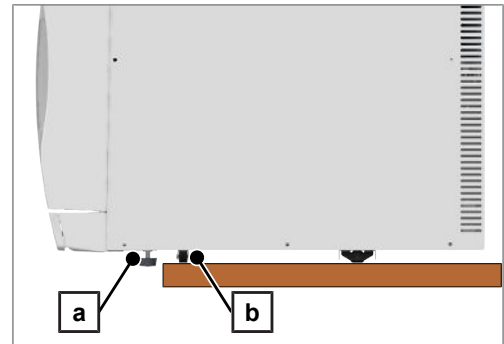

↳ The middle caster (pos. b) remains on the worktop.

6. Loosen the hexagon nuts (AF 13) on the device feet.
7. Unscrew the hexagon nuts until they touch the device feet.
8. Screw in the device feet completely.
9. Turn the device on the worktop in the desired direction.  
↳ The device does not need to be lifted.
10. Carry out the necessary work on the device.
11. Turn back the device.

## Checking the software version

1. Open the status of the device with **i** in the header of the display.
2. Check the software version.
3. Update the software if necessary, see [Software update](#) [▶ page 72].

## Checking water supply and disposal

1. Check the water supply and disposal in the **Settings > Water** menu.
2. If necessary, set the water supply and disposal according to the installation variant, see [Installation examples](#) [▶ page 28].



## Checking date and time

Date and time of the device must be correctly set for proper batch documentation. Ensure that you take into account any clock change, as this is not adjusted automatically.

1. Check the date and time in the header of the display.
2. If necessary, set the date and time in the **Settings** menu, see [Date and time](#) [▶ page 64].

## Checking the display brightness and volume

1. If necessary, adjust the brightness of the display in the **Settings** > **Brightness** menu, see [Display brightness](#) [▶ page 65].
2. If necessary, adjust the volume in the **Settings** > **Volume** menu, see [Volume](#) [▶ page 65].

## Test runs

Carry out the following test runs after the installation and record the results in the installation log.

### **Drain test**

Carry out a drain test after installing the water supply/disposal.

**PLEASE NOTE:** In case of parallel operation of multiple devices, include the wastewater quantity of all devices and perform the test while the other devices are in operation.

- ▶ Pour 500 ml into the overflow funnel.
  - ↳ The overflow funnel must empty within 30 s.

### **Vacuum test with cold sterilization chamber**

Carry out a **vacuum test** with an empty, cold sterilization chamber.

### **Universal-B program**

If the vacuum test was successful, run the **Universal-B** program with 1.5 kg load (instruments).

### **Check for leaks**

After the **Universal-B** program, check the installed hose connections for leaks.

## Electrical test in accordance with EN 50678 (VDE 0701) or national standard

This check is only necessary if the housing has been opened.

## Resetting the maintenance counter

The maintenance counter runs even in device not yet in operation.

- ▶ Reset the maintenance counter, see separate instructions "Resetting the maintenance counter" (doc. AS\_001-21).



## Instructing the users

Explain all user-typical properties for the documentation and setting options for the user in accordance with the record of installation.

The documents included in the scope of delivery (e.g. works test certificate) must be kept by the operator. The declaration of conformity of the Pressure Equipment Directive and the Medical Devices Regulation are included in the manufacturer's inspection report.

## Service connection

### PLEASE NOTE

While using the service connection with MELAtrace, no other activities may be carried out at the device.

The service connection enables the diagnosis of the device and the control of valves via the MELAtrace software.

## Service settings

To make service settings, such as a **Software reinstallation**, you must log in as a **Service technician**, see [Logging on user role](#) [▶ page 69]. Only **authorised technicians** have access to the further service documents required for this purpose.

## 7 First steps

### Starting up the device

The following must be fulfilled or present:

- ✓ The device is connected to the power supply.
  - ✓ The feed water supply is secured, see [Feed water supply](#) [▶ page 43].
  - ✓ The wastewater disposal is secured.
1. Start up the device by pressing the power button, see [Device views](#) [▶ page 11].
    - ➔ The start screen appears on the display.
    - ➔ The double jacket steam generator is preheated after filling.

#### PLEASE NOTE

In the case of automatic feed water supply, the device may attempt to supply feed water into the feed water tank after start-up.

If no feed water is available yet, a malfunction message is displayed, see [Malfunctions](#) [▶ page 81].

2. Wait until the favourites menu is displayed.  
**PLEASE NOTE:** You can start a program immediately without waiting for the ▶preheating time.

Within the first 30 s after the device is started, switch to the **Vacuum test** to prevent automatic preheating.

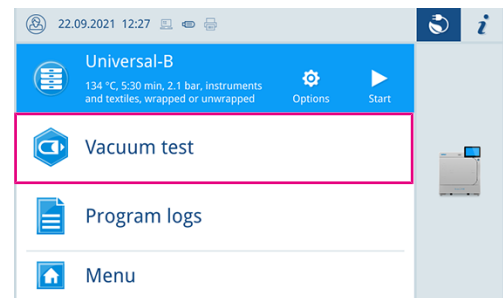

### Opening and closing the door

The device has a motor-driven, automatic door locking mechanism with a threaded spindle.

#### Opening the door

#### PLEASE NOTE

The door is to be left open only whilst loading and unloading the device. Keeping the door closed saves energy.

Please observe the following when opening the door:

- Never use force to open the door.

The following must be fulfilled or present:

- ✓ The device is switched on and booted up.
- ▶ Open the door by pressing **OPEN DOOR**.  
The button is displayed when the menu area is minimised.

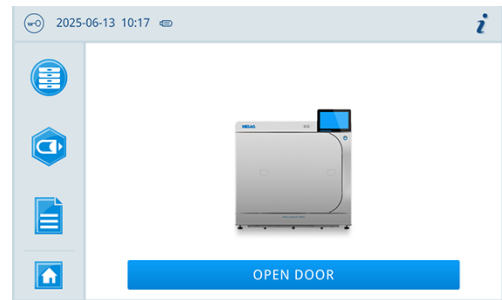

↳ The door unlocks automatically.

### Closing the door

When closing the door, comply with the following instructions to guarantee faultless operation of the door locking mechanism:

- Do not slam the door.
  - Keep pressing the door closed until the door lock engages.
1. Press the door firmly for at least 3 s.
    - ↳ The door locks automatically.
    - ↳ After the door has been closed, the display returns to the default view.
    - ↳ The door is locked pressure-tight upon program start.

### Manual door emergency opening

The door can be opened manually via the emergency opening following a power failure or malfunction.

1. Switch off the device and remove the power plug from the socket.
2. Remove the cover cap (pos. a) in order to enable the emergency door opening by pressing the cover cap in on one side.

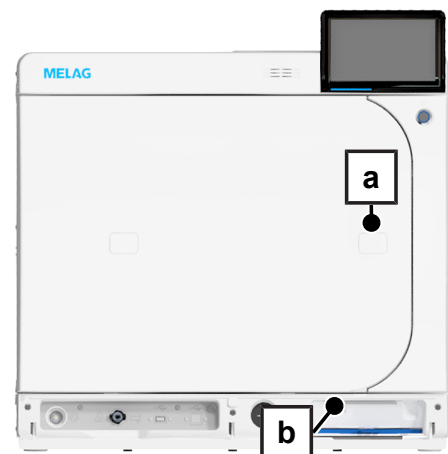

3. Insert the Allen key (5 mm) included in the scope of delivery into the opening. The Allen key can be stored in the specially designed bracket behind the service hatch (pos. b).

**⚠ CAUTION****Warning of scalding**

When opening the door in an emergency, hot steam may escape and there may be hot water in the sterilization chamber. This could result in scalding.

- Never touch the loading slide, the load, the sterilization chamber, the mount or the inside of the door with bare hands.
- Use a tray lifter or heat protection gloves to remove the load.

4. Tighten the Allen key clockwise.
  - ↳ The door opens a crack.
5. Remove the Allen key.
6. Open the door and return the cover cap.

## Feed water supply

Steam sterilization requires the use of ▶distilled or ▶demineralised water, known as ▶feed water. Annex C of ▶EN 13060 specifies the guideline values to be observed.

The feed water is either supplied via a separate water treatment unit (e.g. MELAdem 47), a filling pump with external storage container or, in emergency mode, via the internal storage tank.

The steam sterilizer requires approx. 5 l of feed water for the first filling of the steam generating system.

## Using of a water treatment unit

To protect the drinking water system, a water treatment unit is connected via a safety device by an ▶authorised technician in accordance with the national ordinance. The respective system is selected in accordance with the number of sterilization runs per day and the type of the load.

**ⓘ PLEASE NOTE**

Should you wish to use a water treatment unit from another manufacturer, consult MELAG.

## Using an external storage container

**⚠ WARNING****Warning of contamination**

Algae growth contaminates the feed water in the storage container.

- To prevent algae from forming, do not expose the storage container to sunlight.

For the feed water supply via an external storage container, the feed water is pumped into the device via a filling pump. For a storage container with a capacity of 25 l, the quantity of feed water is sufficient for at least 12 sterilizations.

1. Fill the storage container with a sufficient quantity of demineralised water.
2. Before each program start, check the condition and level of the feed water in the storage container.

## Using the feed water tank (emergency operation)

The manual filling of the internal feed water tank is only used for emergency operation (e.g. failure of the water treatment unit). The feed water tank holds a maximum of 4.2 l. This volume of feed water is sufficient for one sterilization.

1. Open the cover of the feed water tank.
2. Fill the tank up to the MAX mark of the level increase with fresh [feed water](#).
3. Switch the water supply to **Manual**, see [Water](#) [▶ page 68].

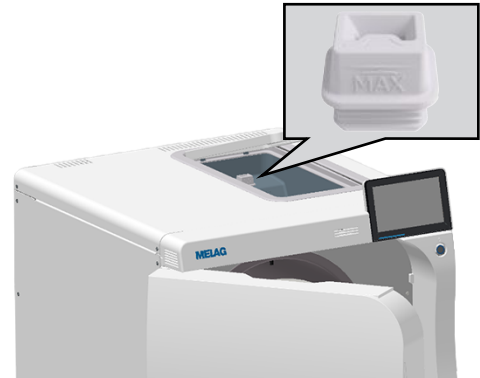

## Disposal of the wastewater

The Vacuclave 550 has an internal wastewater tank.

The wastewater is either drained automatically via the overflow funnel or it is collected in an external wastewater container and is drained manually.

**NOTICE****Water damage due to overflowing wastewater container**

- When draining manually, check the level in the wastewater container regularly.

# 8 Important information for routine operation

Comply with the recommendations issued by the Robert Koch Institute (▶[RKI](#)) and the information contained in ▶[DIN 58946-7](#).

**Manufacturer’s recommendation for the routine operation of type B steam sterilizers<sup>2)</sup>**

When is it necessary to make checks?	How should the checks be made?
Once per working day	<ul style="list-style-type: none"> <li>• Visual check of the door gasket and the door lock for damage</li> <li>• Check the operating media (electricity, ▶<a href="#">feed water</a> and water connection if necessary)</li> <li>• Check the documentation media (printer paper, computer, network)</li> </ul> <p>MELAG recommends performing the steam penetration test with MELAcontrol Helix/MELAcontrol Pro in the Universal-Program.</p>
Once a week	<ul style="list-style-type: none"> <li>• Vacuum test</li> <li>• <b>Tip:</b> In the morning, before starting work – the steam sterilizer must be cold and dry</li> </ul>
Batch-related tests	<p>With “Critical B” instruments:</p> <ul style="list-style-type: none"> <li>• MELAcontrol Helix/MELAcontrol Pro must be used as ▶<a href="#">batch</a> control with every sterilization cycle.</li> </ul> <p>With “Critical A” instruments:</p> <ul style="list-style-type: none"> <li>• The process indicator (type 5 in accordance with ▶<a href="#">EN ISO 11140</a>) must be used as batch control with every sterilization cycle.</li> </ul> <p>With “Critical A + B” instruments:</p> <ul style="list-style-type: none"> <li>• MELAcontrol Helix/MELAcontrol Pro must be used as batch control with every sterilization cycle.</li> </ul> <p>This simplifies the working procedure and increases security. You can omit the daily steam penetration test with MELAcontrol Helix/MELAcontrol Pro (see above). The use of another test system is possible. The number of the available test systems means that MELAG is not able to provide technical support when using a different system.</p>

**PLEASE NOTE**

Document the results of the tests. The test strips used need not be stored.

<sup>2)</sup>in accordance with the current recommendations from the Robert Koch Institute

## 9 Sterilization

---

### Preparing the load

Always clean and disinfect properly before sterilization. Only in this way is it possible to guarantee the subsequent sterilization of the [▶load](#). The materials used, cleaning agents and reprocessing procedure are of decisive significance.

Comply with the following for safe handling:

- Only ever use packaging material and systems which have been cleared by their manufacturer for steam sterilization.
- Only use original MELAG articles or third-party articles approved by MELAG. No warranty can be provided for non-approved third-party articles, even if validation has been successfully carried out.

### Reprocessing instruments

Unwrapped sterile material loses its sterility on contact with ambient air. If you intend to store your instruments sterilely, wrap them in suitable packaging before sterilization.

When [▶reprocessing](#) used and brand-new instruments, comply with the following:

- Always observe both the instrument manufacturer's reprocessing instructions and the relevant standards, guidelines and directives (in Germany, for example, from [▶RKI](#), [▶DGSV](#) and [▶DGUV Regulation 1](#)).
- Clean the instruments exceptionally thoroughly e.g. using an ultrasonic device or washer-disinfector.
- Rinse the instruments after washing and disinfecting, where possible with demineralised or distilled water, and then dry the instruments thoroughly with a clean, non-fuzzing cloth.
- Re-dry the spray, air and water channels using medical compressed air.
- Use only those care agents suitable for steam sterilization. Consult the manufacturer of the care agents. Do not use any water repellent agents or oils impermeable to steam. MELAG recommends the use of MELAG Care Oil Spray.
- When using ultrasound devices, care equipment for handpieces and washer-disinfectors, comply with the manufacturer's reprocessing instructions.
- Remove any residual disinfection and cleaning fluids to avoid corrosion. Otherwise, this could result in increased maintenance requirements and a restriction of the device function.

### Reprocessing textiles

The incorrect reprocessing of textiles, e.g. a textile package can prevent steam penetration or produce poor drying results. This may result in the textiles **not** being sterile.

Comply with the following points when [▶reprocessing](#) textiles and placing the textiles in sterile containers:

- Comply with both the reprocessing instructions of the textile manufacturer the relevant standards, guidelines and directives (in Germany e.g. of the [▶RKI](#) and [▶DGSV](#)).
- Arrange the folds in the textiles parallel to each other.
- Stack textiles vertically wherever possible and not too closely together in the sterile container. This enables the development of flow channels.
- If textile packages do not remain together, wrap the textiles in sterilization paper.
- Only ever sterilize dry textiles.
- The textiles may not be permitted to come into direct contact with the sterilization chamber; otherwise they will become saturated with [▶condensate](#).

## Loading the steam sterilizer

Effective sterilization and good drying is only possible if the steam sterilizer has been loaded correctly.

Ensure the following during loading:

- Insert trays in the chamber only with their appropriate mount.

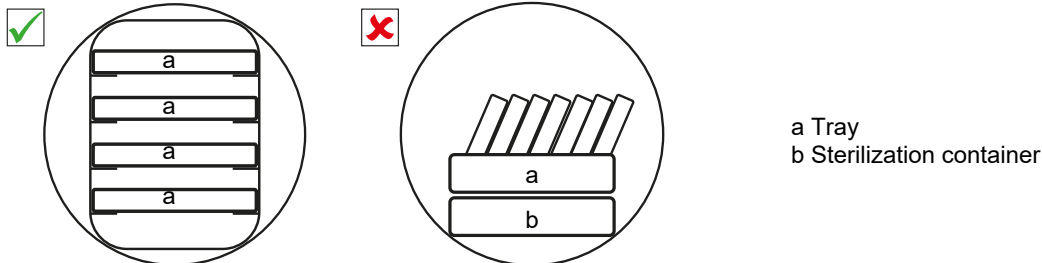

- Wherever possible, ensure the separate sterilization of textiles and instruments in separate sterile containers or sterilization packages. This leads to better drying results.
- The use of paper tray inserts can result in poor drying results.
- Use perforated trays such as those from MELAG. Only in this way can condensate drain off. Non-perforated bases or half-shells for holding the load lead to poor drying results.

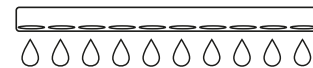

### Packaging

Only ever use packaging materials and systems (sterile barrier systems) which fulfil the standard EN ISO 11607-1. The correct use of suitable packaging is important in achieving successful sterilization results. You can use re-usable rigid packaging systems or soft packaging such as transparent sterilization package, paper pouches, sterilization paper, textiles or fleece.

### Closed sterile containers

Please comply with the following when using closed sterile containers:

- Use aluminium sterile containers. Aluminium retains and conducts heat and thus accelerates drying.
- Closed sterile containers must be either perforated or have a valve on at least one side. MELAG sterile containers, e.g. MELAstore Box, fulfil the requirements for successful sterilization and drying.
- Wherever possible, ensure that sterile containers are only stacked on top of those of identical size, so that the condensate can run down their sides.
- Ensure that the perforations are not covered when stacking the sterile containers so that the condensate can drain off.

### Soft sterilization packaging

Soft sterilization packages can be used in both sterile containers and on trays. Please comply with the following when using soft sterilization packages e.g. MELAfol:

- Arrange transparent sterilization packages on edge and close together. If this is not possible, place them with the paper side facing downwards.
- Do not place multiple soft sterilization packages flat on top of each other on a tray or in a container.
- When loading the steam sterilizer, make sure that either the film or paper sides of different pouches are facing each other.
- If the seal seam tears during sterilization, this could be caused by the choice of undersized packaging. Pack the instruments with larger packaging and perform sterilization again.
- Should the seal seam tear during sterilization despite sufficient bag size, adjust the sealing temperature on the sealing device or make a double seam.

## Multiple wrapping

The device uses a fractionated vacuum procedure. This permits the use of [multiple wrapping](#).

## Mixed loads

Please observe the following when sterilizing [mixed loads](#):

- Always place textiles at the top
- Sterile containers at the bottom
- Place unwrapped instruments at the bottom
- Place the heaviest loads at the bottom
- Transparent sterilization packages and paper packages on the top. Exception: At the bottom in combination with textiles

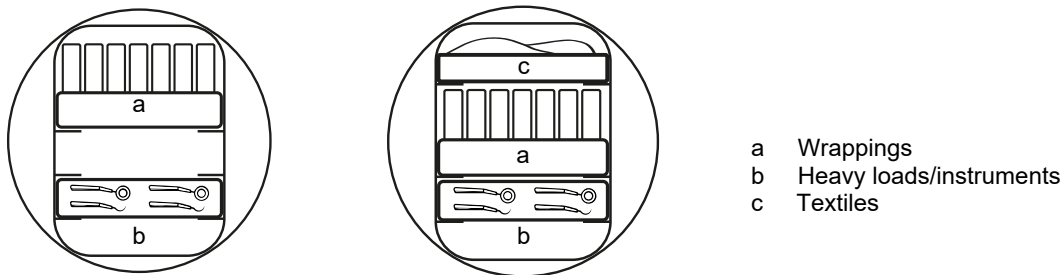

## Load quantities

### Max. weight per component

Load <sup>*)</sup>	
Max. weight per component	2 kg
*) for MELAG mounts, trays, sterile containers, see <a href="#">Components, accessories and spare parts</a> [▶ page 92]	

## Selecting the program





All sterilization programs are displayed in the **Programs** menu. The following tables list the correct program for each [load](#).

When selecting the sterilization program, proceed as follows:

- Select the sterilization program based on which products you want to sterilize.
- Select the sterilization program according to whether and how the load is wrapped.
- Observe the permissible max. load quantities.
- Note the temperature resistance of the load.

**Overview of sterilization programs**

The maximum current draw of the device can be set to 13 A or 15 A. Depending on the current draw set, different load quantities can be sterilized. The setting is made by an **authorised technician** depending on the local electrical installation when the device is setup. The setting can be viewed under **Device status > Device > Power limitation**.

Program	Especially suitable for	Maximum load quantity		Operating time*)	Drying		
		15 A	13 A				
 Universal-B 134 °C 2.1 bar 5:30 min	<ul style="list-style-type: none"> <li>• Transmission instruments</li> <li>• Products with narrow lumen</li> <li>• Simple hollow bodies</li> </ul>	Instruments:			13-43 min	5-30 min	
		• single wrapped	12 kg	10 kg			
		• double wrapped	11 kg	9 kg			
		• unwrapped	25 kg	17 kg			
		Textiles:					
		• double wrapped	3.5 kg	2 kg			
		Sterile container	17.5 kg	14 kg			
 Quick-S 134 °C 2.1 bar 3:30 min	<ul style="list-style-type: none"> <li>• Simple solid instruments</li> <li>• Simple hollow bodies</li> </ul>	Instruments:			12-33 min	5-30 min	
		• unwrapped	20 kg	17 kg			
		No textiles and sterile containers					
 Gentle B 121 °C 1.1 bar 20:30 min	<ul style="list-style-type: none"> <li>• Thermo-unstable equipment (e.g. plastic, rubber, textiles)</li> <li>• Products with narrow lumen</li> <li>• Simple hollow bodies</li> </ul>	Instruments:			25-62 min	5-30 min	
		• single wrapped	12 kg	10 kg			
		• double wrapped	11 kg	9 kg			
		• unwrapped	25 kg	17 kg			
		Textiles:					
		• double wrapped	3.5 kg	2 kg			
		Sterile container	17.5 kg	14 kg			
 Prion-B 134 °C 2.1 bar 20:30 min	Instruments with more stringent sterilization requirements**): <ul style="list-style-type: none"> <li>• Products with narrow lumen</li> <li>• Simple hollow bodies</li> </ul>	Instruments:			28-58 min	5-30 min	
		• single wrapped	12 kg	10 kg			
		• double wrapped	11 kg	9 kg			
		• unwrapped	25 kg	17 kg			
		Textiles:					
		• double wrapped	3.5 kg	2 kg			
		Sterile container	17.5 kg	14 kg			

\*) Without drying, with a minimal to full load and dependent on the load / packaging and setup conditions (such as e.g. mains voltage) If the device is started cold, the time may be extended by a few minutes.

\*\*) The Prion-Program provides an extended plateau period at 134 °C to help reduce the risk of prion transmission - particularly when users comply with the applicable national or institutional requirements for handling potential prion contamination. The Prion-Program does not ensure complete inactivation of prions and does not claim prion inactivation.

Use the Prion-Program only as part of a validated overall reprocessing procedure, including thorough pre-cleaning and, where required, chemical prion decontamination in accordance with the applicable guidelines.

Use the Prion-Program only in accordance with the national or international guidelines applicable to you, e.g. "Hygiene requirements for the reprocessing of medical devices. Recommendation of the Commission for Hospital Hygiene and Infection Prevention (**KRINKO**) at the Robert Koch Institute (**RKI**) and the Federal Institute for Drugs and Medical Devices (**BfArM**)" (2012, PMID: 23011095; German national guideline).

Always discard reusable medical instruments that have been in contact with high- or medium-risk tissue from patients with suspected or confirmed Creutzfeldt-Jakob disease - whether owned or borrowed. Prion proteins may be resistant to conventional sterilization processes!

## Options

Use the **Options** button to customize default settings for the selected program. Basic default settings can be configured in the Program options menu, see [Program options](#) [▶ page 66].

1. Press the **Options** button.

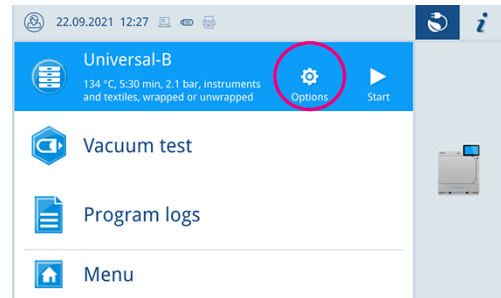

2. Press **>** to change the drying type.

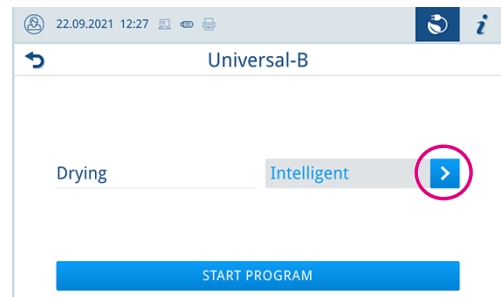

3. Select the desired option and confirm it with **OK**.

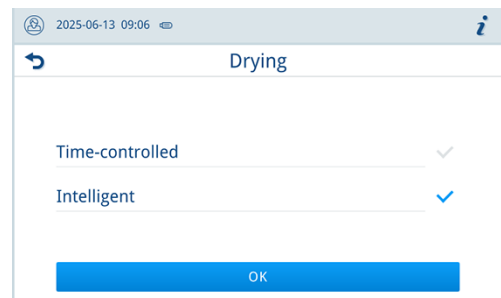

4. Start the program with **START PROGRAM**.
5. If **Authentication at Reprocessing program start** is activated, enter the PIN, see [Authentication](#) [▶ page 71].
6. Confirm the subsequent dialogue window with **START PROGRAM**.

## Starting the program

The following must be fulfilled or present:

- ✓ The load has been cleaned and disinfected, see [Preparing the load](#) [▶ page 46].
- ✓ The device is loaded correctly, see [Loading the steam sterilizer](#) [▶ page 47].
- ✓ The max. load quantity has not been exceeded, see [Selecting the program](#) [▶ page 48].
- ✓ The date and time are set correctly, see [Date and time](#) [▶ page 64].
- ✓ The desired program has been selected.

1. Press **START PROGRAM**.

➔ The door locks pressure-tight upon program start. The device checks the quantity of feed water and its conductivity.

2. If **Authentication at Reprocessing program start** is activated, enter the PIN, see [Authentication](#) [▶ page 71].

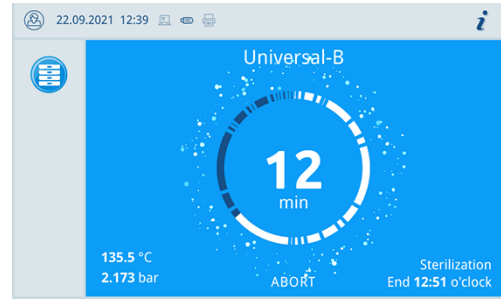

## Aborting the program manually

You can abort the program at any time. If you abort the program before the end of the sterilization phase, the load is **not** sterile.

### ⚠ WARNING

#### Warning of contamination

If a program is terminated before drying starts, the load is **not** sterile.

- Re-wrap the load if necessary.
- Repeat the sterilization of the load.

### ⚠ CAUTION

#### Warning of scalding

When the door is opened after a program abort, hot steam may escape and hot water may be present in the sterilization chamber. This could result in scalding.

- Never touch the load, the sterilization chamber, the mount or the inside of the door with bare hands.
- Use a tray lifter or heat protection gloves to remove the load.

1. Press **ABORT** to abort a program.

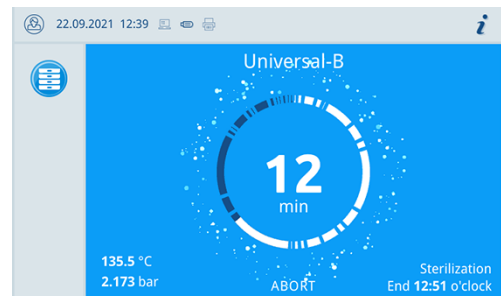

2. Confirm the security query with **YES**.

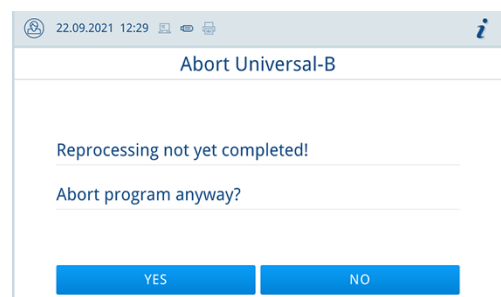

- ➔ The load is **not** sterile.
- ➔ Cancelling the program can take a few minutes as steam and condensate are removed from of the chamber.

- Press **OPEN DOOR** to remove the load.

**PLEASE NOTE:** By pressing , you can display additional values for the completed program (e.g. the plateau period or the conductivity).

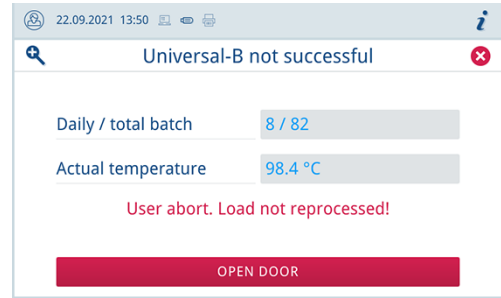

## Ending the program prematurely

You can exit the program during the drying. If you exit the program before the drying has finished, the load is not completely dried and should be used immediately.

The following must be fulfilled or present:

- ✓ The reprocessing program is in the drying phase.

- To end the program prematurely, press **END**.

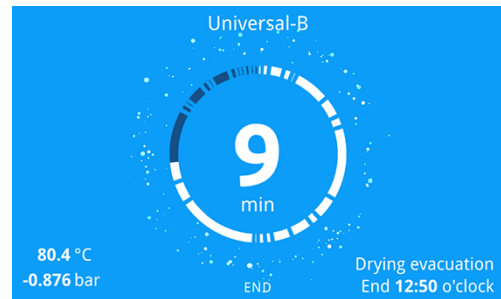

- Confirm the end of drying with **YES**.

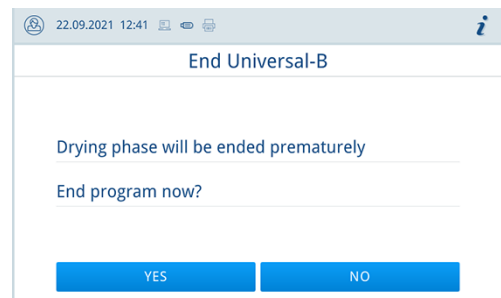

➔ The program will be aborted prematurely.

## Program is ended

**PLEASE NOTE**

If the program has been carried out successfully, a corresponding message appears on the display and the status LED below the display illuminates green.

- Repeat the program if the display indicates the program was unsuccessful or the LED does not light up green.

- Press **OPEN DOOR** to remove the load.

**PLEASE NOTE:** By pressing , you can display additional values for the completed program (e.g. the plateau period or the conductivity).

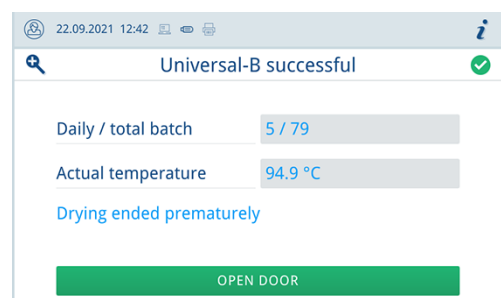

2. If **Authentication at Reprocessing program end** is activated, enter the PIN, see [Authentication](#) [▶ page 71].

If automatic log output after the end of the program is activated in the **Settings > Log output** menu, the log of the run program is output to the activated output media after the door is opened.

## Approval process

According to ▶RKI “Anforderungen an die Hygiene bei der Aufbereitung von Medizinprodukten” [Hygiene requirements for the reprocessing of medical devices], instrument reprocessing ends with the documented approval of the ▶sterile material. The approval process consists of the indicator assessment and batch approval. Both must be performed by authorised and competent personnel.

### Indicator assessment

The following must be fulfilled or present:

- ✓ Batch approval is activated, see [Batch approval](#) [▶ page 71].
  - ✓ Indicator assessment is activated, see [Batch approval](#) [▶ page 71].
1. Remove the batch checker from the sterilization chamber and check the result.
  2. Evaluate the result on the display.

If the indicator has changed colour or no indication has been given, the batch can be released. If the indicator has not changed colour, batch approval is not possible.

➔ The result of batch approval and indicator assessment is logged and program post-processing continues.

### Batch approval

The batch approval includes checking the process parameters using the sterilization results at the device and the sterilization log as well as checking the individual packaging for damage and residual moisture. The sterilization log records the approval of the ▶batch and any indicators.

The following must be fulfilled or present:

- ✓ Batch approval is activated, see [Batch approval](#) [▶ page 71].
1. When prompted for batch assessment, press **YES** to release the batch.
  2. If a user PIN is required to release the batch, enter the PIN; see [Authentication](#) [▶ page 71].

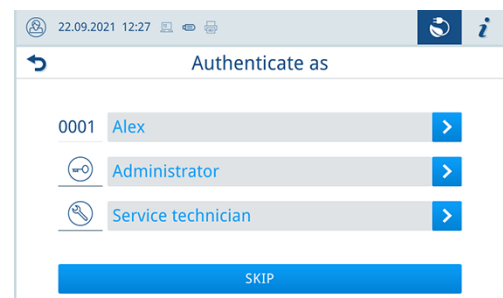

➔ The batch approval result is logged and program post-processing continues.

## Removing the sterile material

### ⚠ WARNING

#### Warning of contamination

If packaging is damaged or has burst after sterilization, the instruments are unsterile.

- Re-wrap the load.
- Carry out the sterilization again.

### ⚠ CAUTION

#### Warning of burns

After a program cycle, the sterilized items are hot. There is a risk of burns from hot parts and hot condensate during removal.

- Never touch the sterile material, the sterilization chamber, the mount or the inside of the door with bare hands.
- Use a tray lifter or heat protection gloves to remove the load.

If you remove the [▶sterile material](#) from the device directly after the end of the program, it is possible that the instruments can be partially damp. According to the red brochure of the Arbeitskreis für Instrumentenaufbereitung ([▶AKI](#)), single drops of water (no puddles) that dry off within 15 min are considered tolerable residual moisture in practice.

Comply with the following specifications when removing the sterile material:

- Never use force to open the door. This could damage the device or result in the emission of hot steam.
- Hold the mount level when removing it from the device. Otherwise, the load could slide off.
- Keep the trays horizontal when removing them from the device. Otherwise, the load could slide off.
- When removing the load from the device separately, ensure that the mount does not slide out unintended.
- Use both hands or two tray lifters to remove large or long trays.

## Storing sterile material

The maximum storage time is dependent on the packaging and the storage conditions. Please observe the regulatory requirements for the storage period of [▶sterile materials](#) (in Germany e.g. [▶DIN 58953](#), Part 8 or the [▶DGSV](#) guidelines) as well as the following listed criteria:

- Follow the manufacturer's instructions on the packaging, e.g. when setting the storage period at the label printer. Comply with the maximum storage duration in accordance with the packaging type.
- Store the sterile material in a dust-protected environment e.g. in a closed instrument cabinet.
- Store the sterile material in an environment protected against moisture.
- Store the sterile material in an environment protected against excess temperature variations.

# 10 Logging

## Batch documentation

The batch documentation serves as proof of the successful conclusion of the program and represents an obligatory part of quality assurance. The device internal log memory saves such data as the program type, [▶batch](#) and process parameters of all the programs completed.

To obtain the batch documentation, you can output the internal log memory and transfer its data to various output media. This can be performed immediately at the end of every program or at a later point, such as at the end of the day.

If authentication is activated, the user ID and the result of the approval process are documented in the log header and, if required, on a label.

### Capacity of the internal log memory

All data of the programs run are stored automatically in the internal log memory. The capacity of the internal log memory is sufficient for 100 logs.

If the internal log memory is full, a warning appears on the display. In this case, output the logs concerned onto the defined [output medium](#) [[▶ page 55](#)]. If you continue the program without outputting the logs, the oldest log is overwritten automatically.

The number of free log memory locations can be viewed under **Device status > Device**.

MELAG recommends outputting logs automatically, see [Log output](#) [[▶ page 67](#)].

## Output media



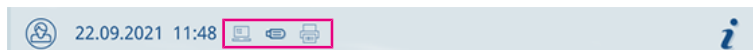

The following output media can be activated and configured in the **Settings > Log output** menu for batch documentation or log output:

- MELAtrace
- FTP
- USB
- Printer

For activated output media, the symbol in the information area is displayed faintly. For activated and connected output media, the symbol is displayed in full. Output media that are not activated are not displayed, even if they are connected.



**PLEASE NOTE** You can only connect one USB storage medium.

Symbol	Output media	Description
	USB flash drive	Output to a USB stick connected to the USB port
	FTP	Output to an FTP server
	MELAtrace	Output to MELAtrace
	MELAprint 60 <sup>3)</sup> /80	Output to a connected label printer

<sup>3)</sup> from model BTP-580II

### Label printer

The use of a label printer facilitates batch traceability. By entering the following data, the sterile material can be assigned to the patient and the sterilization batch:

- Sterilization date
- Storage duration
- Batch number (daily / total batches)
- User ID (person who has authorised the sterile material for use)
- Device (type, serial number, program used)
- File name

For further information on setting up the label printer, see [Label print](#) [▶ page 68].

Faultless packages containing sterile material are marked with labels after sterilization. As such, the preconditions for correct approval by the person conferred with the task of reprocessing are given. All information regarding the correct reprocessing process can be attributed to the instruments used in patient records.

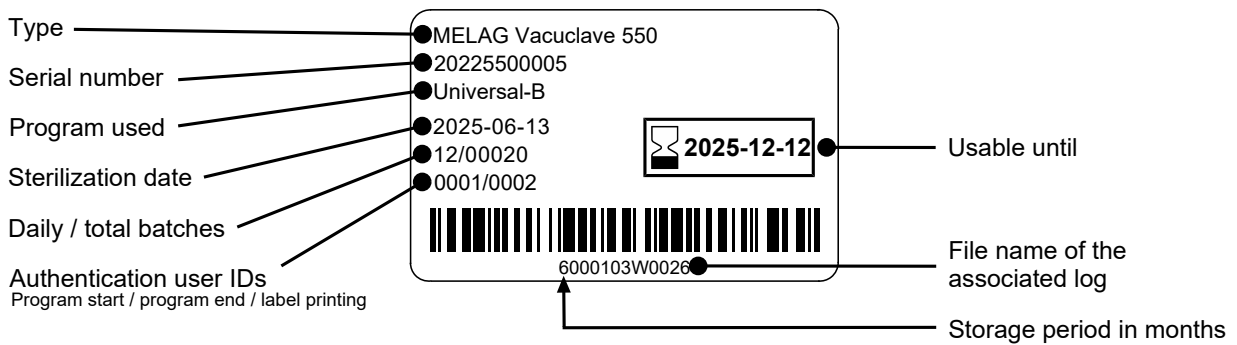

### Displaying logs on the computer

The log files are generated in html format and can be displayed and printed on the computer with a web browser or in MELAtrace.

The program, malfunction and status protocols contain a legend entry for each line. The program logs contain graphic data and can be displayed as graphic logs in MELAtrace.

000	Device ID	1004200010	000	Ident informations of the device
010	File name	2021-04-21_00025_20205500010_UNI_OK_100400A000R	010	File name of the log
020	Device type	Vacuclave 550	020	Device type
030	Program name	Universal-B Program	030	Program name
035	Program type	134 °C wrapped	035	Program type
040	Date	21.04.2021	040	Creation date of the log
045	Daily / total batch	05 / 00025	045	Daily batch number and total batch number
050	User program start	deactivated	050	User ID at program start
055	User program end	deactivated	055	User ID at program and batch approval
060	Indicator changed	deactivated	060	Indicator assessment
065	Batch approved	deactivated	065	Status batch approval
070	Program result	Program successfully completed	070	Program result
141	Sterilization temperature	135.6 ±0.11/-0.49 °C	141	Sterilization temperature with max. deviation
143	Sterilization pressure	2.17 ±0.00/-0.04 bar	143	Sterilization pressure with max. deviation
144	Plateau time	5 min 30 s	144	Sterilization time
150	Conductivity	13 µS/cm (444 ml : 74.9 l*µS/cm)	150	Conductivity of feed water and feed quantity
155	Start time	10:13:27	155	Time at program start
156	End time	10:59:53 (46:26 min)	156	Time at program end and program duration
160	Device serial number	20205500010	160	Serial number of the device

Step	Start [m:s]	End [m:s]	Dauer [m:s]	P [mbar]	T [°C]	
Program start						
SP-S	00:00	00:00	00:00	c 0	c 0.0	Program start

## Saving logs

### Storage location for logs

When transferring the logs to a USB stick, they will be stored in a separate folder in the main directory.

Transfer of the logs to a computer via the network and using the MELAG ▶FTP server allows you to work in the FTP server to determine directly where on your computer the device directory with log files is to be saved.

With output via MELAtrace, you can work in the program to determine the folder in which they are to be saved.

### Log directory

A folder is created on all memory media (USB stick or computer) after log output containing the serial number of the issuing device. This folder contains sub-folders with the month of log generation e.g. 2021-01 for January 2021. This contains all logs generated by the device this month.

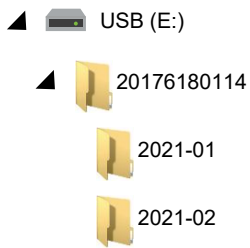

## Logs menu

The **Logs** menu provides you with the following options:

- Display and output of program logs
- Display and output of malfunction logs
- Display and output of status log
- Display and output of system log
- Printing of labels, see [Label print](#) [▶ page 68]

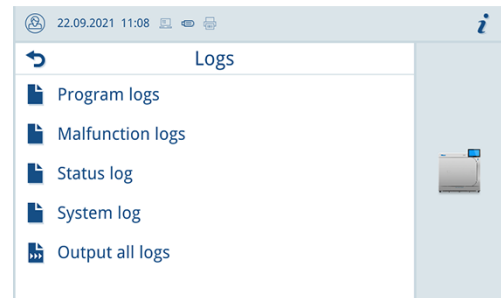

You can issue logs subsequently and independently of the time of a program end. Before the log output, you can select the output media, see [Output media](#) [▶ page 55].



### Log types

Log type	Description
Program log	Log of a program
Malfunction logs	Log with faults that occurred outside a program run
Status log	Summary of all important settings and system statuses
System log	List of all the malfunctions and changes to the system in order of time (log book) The system log is output in English.

**List of logs**

In the log list you can view all logs in detail. It displays all the logs present in the memory. You can sort the list by pressing the column headings.

The **Result** column shows symbolically whether the program ended successfully or not.

Symbol	Description
	Program completed successfully
	Program not completed successfully

Logs that have not yet been output are marked with a dot in the **New** column.

**Outputting logs**

1. In the log list, press the button with the arrow to view and output a log.

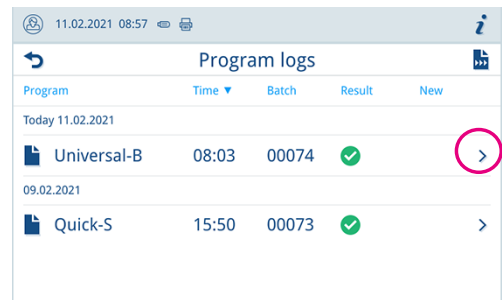

2. Press **OUTPUT LOG** to output the displayed log.

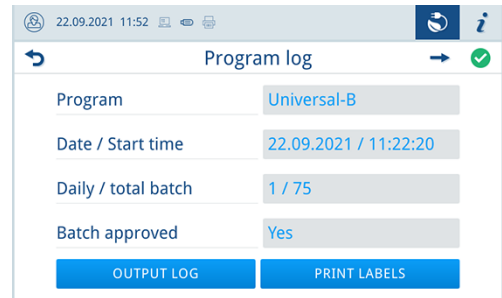

→ The **Log output options** are opened, see [Log output options](#) [▶ page 58].

**Log output options**

In the **Log output options** menu you can set the type of logs to be output and the output medium.

The following settings are possible:

Output status	Description
Not output	All logs that are not output will be output.
Last	The log of the last successful completed program is output.
All	All logs of the selected log type are output.

1. In the log list, press the button at the top right to customise the **Log output options** and output multiple logs.

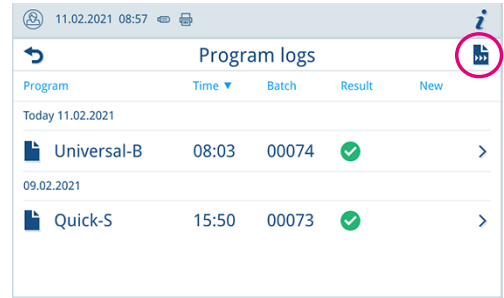

2. Press the button with the arrow (pos. a) to select the desired output status.

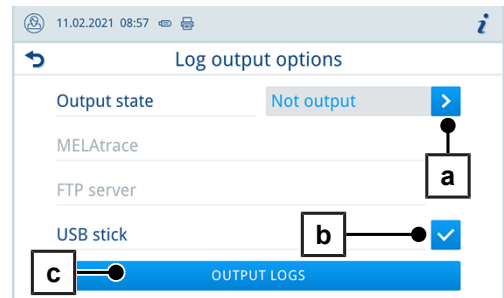

3. Activate at least one output medium (pos. b).
  - ↳ Unavailable output media are greyed out.
4. Press **OUTPUT LOGS** (pos. c).
  - ↳ The output takes place on the selected output media.

## Printing a label

**PLEASE NOTE**

No labels can be printed if the program run has not been completed successfully or the batch has not been released.

1. Press the button with the arrow to view and output a log.

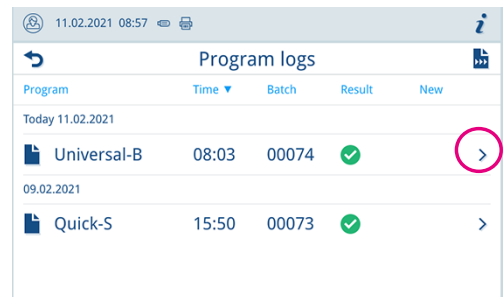

2. Press **PRINT LABELS** to open the label printing dialog.

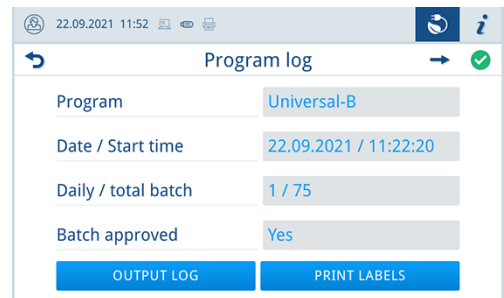

3. Press the button with the arrow to change the **Quantity** or the **Storage duration**.  
**PLEASE NOTE:** The last storage time set is taken over individually for each program as a presetting for the next label printing.

➡ Confirm the changes with **OK**.

4. Press **PRINT LABELS** to print labels for the displayed log.

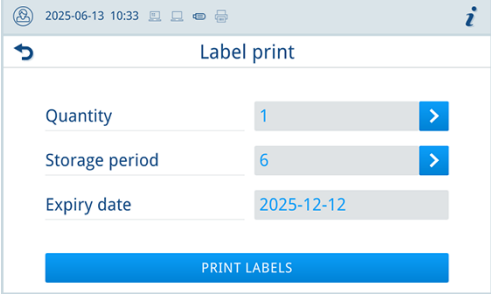



The screenshot shows a mobile application interface titled "Label print". At the top, there is a status bar with the date "2025-06-13 10:33" and various icons. Below the title bar, there is a back arrow icon and the title "Label print". The main content area contains three rows of settings:

Quantity	1	>
Storage period	6	>
Expiry date	2025-12-12	

At the bottom of the form, there is a blue button labeled "PRINT LABELS".

# 11 Function checks

## Service programs

Program name	Program	Operating time	Use/function
Vacuum test		25 min	For measuring the leakage rate, test with a dry and cold device (test without load)
Bowie & Dick test		20 min	Steam penetration test with special test package (available from specialist stockists)
Draining		3 min	For emptying and pressure release of the double jacket steam generator, e.g. for service, decommissioning or before transport

### Vacuum test

The device can be checked for leakages in the steam system using the **vacuum** test. This determines the leakage rate at the same time.

Perform a vacuum test in the following circumstances:

- Once a week in routine operation
- During commissioning
- Following longer operating pauses
- In the case of a corresponding malfunction (e.g. in the vacuum system)

**PLEASE NOTE** Perform the vacuum test with the device in a cold and dry state.

1. Switch on the device.
2. In the **Service programs** menu, select **Vacuum test** and press **Start**.

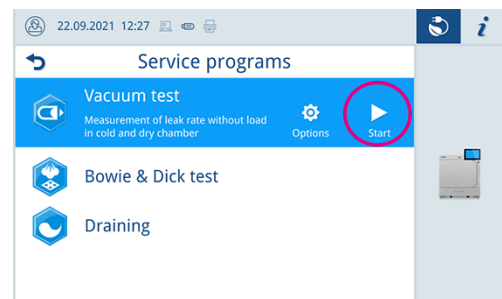

→ The vacuum test is started in the **Default** program version.

→ The leakage rate is shown on the display after the vacuum test has been completed. If the leakage rate is higher than 1.3 mbar, a corresponding message will appear.

**Options for the vacuum test**

Under **Options**, you can extend the vacuum test to areas that are connected to the sterilization chamber. In this way, you can also evaluate their leak tightness.

1. In the **Service programs** menu, select **Vacuum test** and press **Options**.

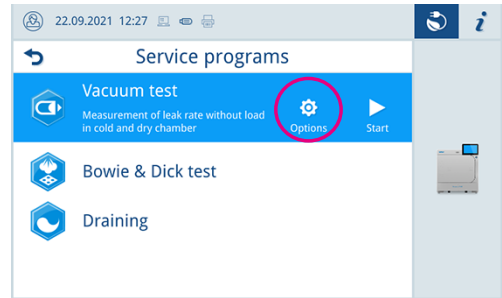

2. Press **>** to select another variant of the vacuum test.

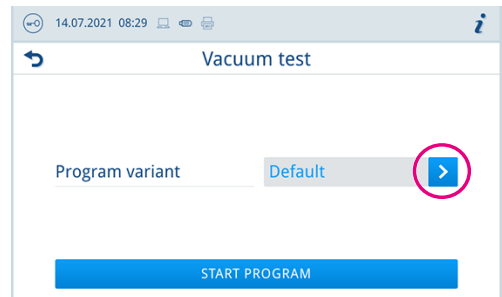

3. Select the required variant and accept it with **OK**.

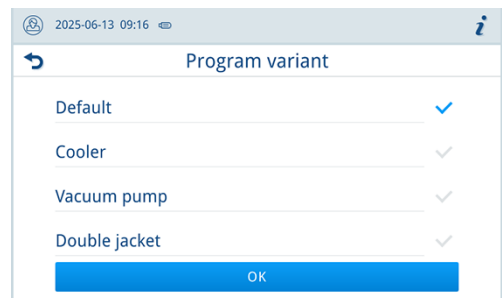

4. Start the vacuum test with **START PROGRAM**.

## Bowie & Dick test

The ▶**Bowie & Dick test** serves as proof of steam penetration of ▶**porous materials** such as e.g. textiles. Use **Bowie & Dick test** service program for a routine function check. Stockists provide various test systems for the Bowie & Dick test. Perform the test according to the test system manufacturer's specifications.

The following must be fulfilled or present:

- ✓ A new test system
  - ✓ The sterilization chamber is empty.
1. Place the test system in the sterilization chamber according to the manufacturer's instructions.
  2. Close the door.
  3. Working in the **Service programs** menu, select the **Bowie & Dick test** and press **Start**.

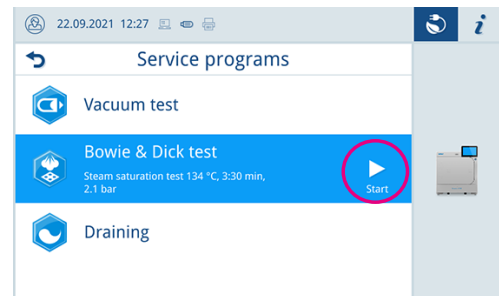

## Draining

You can drain the water in the double jacket steam generator via the **Draining** program. In order to do so, the device is heated once, building up pressure in the double jacket so that the water can be emptied fully from the double jacket steam generator.

1. Working in the **Service programs** menu, select the **Draining** program and press **Start**.

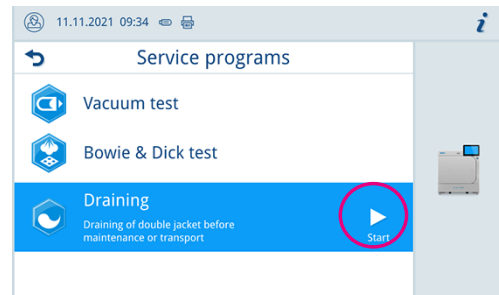

2. Confirm the dialogue window.
  - ↳ The double jacket steam generator is emptied.
3. Confirm the **Draining successful** message.
4. Switch off the device.

# 12 Settings

## General settings

General settings can be changed by any user.

### Language

In the **Settings** > **Language** menu, you can switch between the enabled languages.

1. Set the desired language.

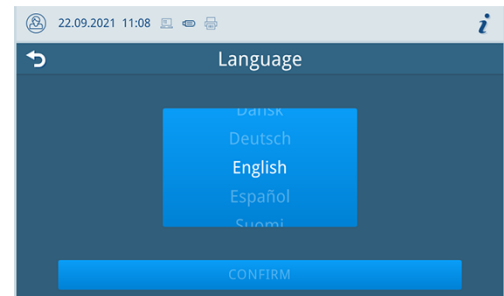

2. Press **CONFIRM** to accept the changes.

→ The dialogues on the display and the log texts are changed to the selected language.

### Date and time

Date and time of the device must be correctly set for proper batch documentation. Ensure that you take into account any clock change in autumn and spring, as this is not adjusted automatically. Set the date and time as follows:

1. Open the **Settings** menu.
2. Select the **Date** menu item.
3. Set the date.

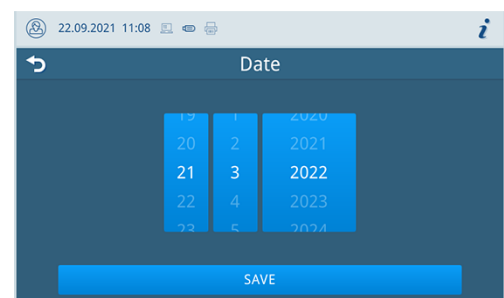

4. Press **SAVE** to accept the changes.
5. Select the **Time** menu item.

- Set the time.

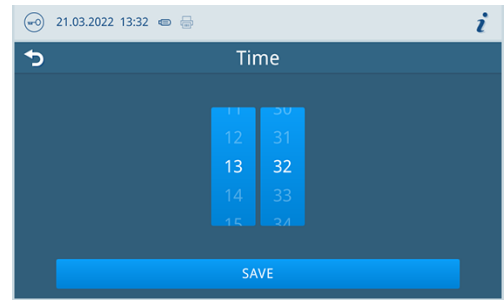

- Press **SAVE** to accept the changes.

## Display brightness

In the **Settings > Brightness** menu, you can set the brightness of the display.

The display brightness is adjusted immediately. The colour bar (pos. a) gives you an impression of the colour contrast.

- Move the slider to the left or right or press the plus (pos. b) or minus (pos. c) buttons.

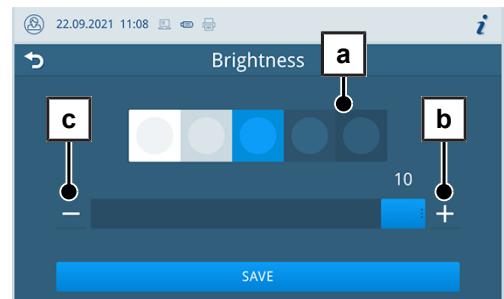

→ The display brightness can be adjusted in ten steps.

- Press **SAVE** to accept the changes.

## Volume

In the **Settings > Volume** menu, you can set the volume of the sound output.

- Move the slider to the left or right or press the minus (pos. a) or plus (pos. b) buttons.

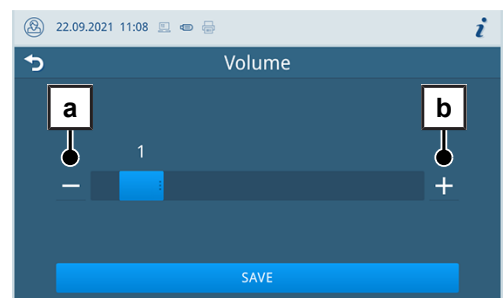

→ The volume can be adjusted in ten steps.

→ At level 0, the sound is switched off.

- Press **SAVE** to accept the changes.

## Energy-saving

In the **Settings > Energy-saving** menu, you can set after how long the device is inactive the heater is switched off.

1. At the number wheel set after how many minutes the heater is switched off automatically.

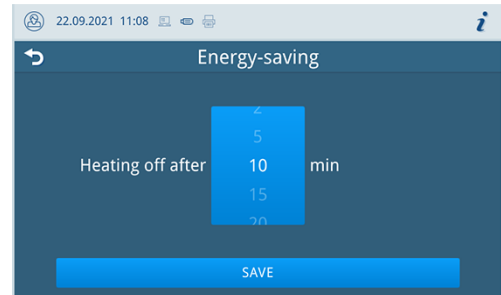

2. Press **SAVE** to accept the changes.

## Program options

In the **Settings > Program options** menu, you can make default settings for drying.

1. Press **>** to make changes.

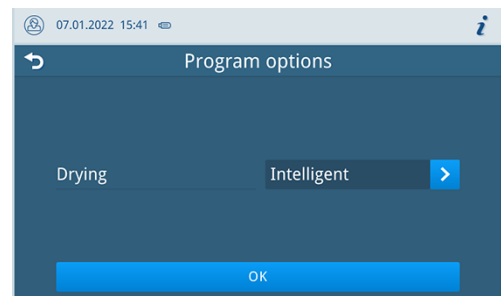

2. Activate or deactivate the desired setting by selecting or deselecting it.
3. Confirm the changes with **OK**.
4. Press **SAVE** to accept the changes.

The following settings are possible:

### ***Time-controlled drying***

With time-controlled drying, the duration of the drying phase is determined by the program.

### ***Intelligent drying***

In contrast to time-controlled drying, the duration of the intelligent drying is automatically calculated using the residual moisture in the sterilization chamber. The drying phase is ended as soon as the load is dry. A number of factors play a role in this process including e.g. the type of the load, wrapped or unwrapped, the load quantity, the distribution of the load in the sterilization chamber etc.

#### **PLEASE NOTE**

Intelligent drying is activated in the delivery state.

## Log output

In the **Settings > Log output** menu, you can set how the log should be output by default for each output medium. The following settings are possible:

Option	Description
Deactivated	No log output possible, even with output medium connected
Manual	Manual log output possible via the log list
Automatic	Automatic log output after program cycle or malfunction

For the option **Automatic** a dialog follows for the definition for which programs the automatic log output should take place.

You can activate the log output for several output media at the same time.

### FTP server

Under the **FTP** menu item, the FTP server is configured via the IP address, the user name and the password.

The **TEST** button can be used to test the set configuration.

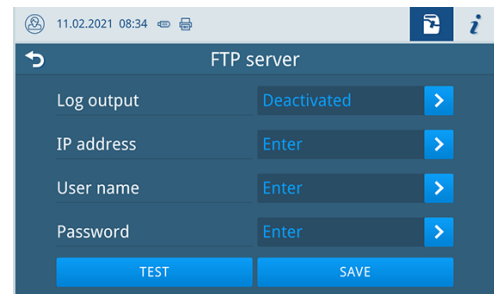

## Network

In the **Settings > Network** menu, you can select an automatic configuration via DHCP or enter the required address details manually.

The following must be fulfilled or present:

- ✓ The logged-in user role is: **Administrator** or **Service technician**.

1. Press **>** to make changes.

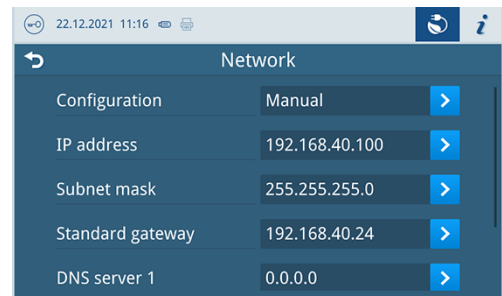

2. Press **SAVE** to accept the changes.

## Label print

In the **Settings** > **Label print** menu, you can configure the label printer and set default settings. The label printer can be connected via the network (LAN), the Ethernet interface, or the USB interface.

1. Press **>** to make changes.

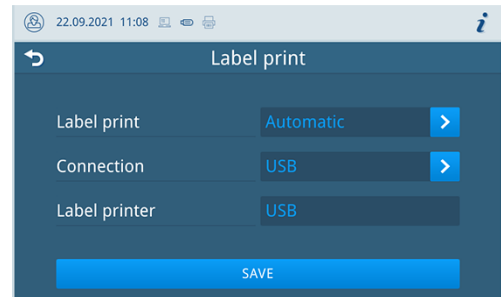

2. Activate or deactivate the desired setting by selecting or deselecting it.
  - ↳ For the option **Automatic** a dialogue follows for the definition for which programs the automatic label print should take place.
3. Confirm the changes with **OK**.
4. Press **SAVE** to accept the changes.

The following settings are possible:

Option	Description
Deactivated	No label print possible, even with label printer connected
Manual	Manual label print possible via the log list
Automatic (immediately after program run)	Label printing dialogue is displayed for the specified programs after each program run.

## Water

In the **Settings** > **Water** menu you can change the water supply and disposal settings. The default setting is **Automatic**.

### Water supply

You can set the feed water supply to **Automatic** or **Manual**.

Designation	Description
Automatic	The feed water is supplied automatically via the MELAdem feed water connection or the filling pump feed water connection.
Manual	The manual feed water supply is only used for emergency operation, see <a href="#">Using the feed water tank (emergency operation)</a> [▶ page 44].

### Water disposal

You can set the disposal of wastewater to **Automatic** or **Manual**.

Designation	Description
Automatic	The wastewater is automatically disposed of via the overflow funnel into the building's wastewater installation.
Manual	The wastewater is disposed of via the overflow funnel into an external wastewater container. The container is monitored by a level sensor and must be emptied regularly. MELAG recommends daily emptying. The capacity of the wastewater container is at least 10 cycles.

## Administrative settings

To make administrative settings, such as changes to the user administration, you must log in as an **Administrator** or **Service technician**, see [Logging on user role](#) [▶ page 69].

### Logging on user role

To log on a user role, proceed as follows:

1. Press the user role button.

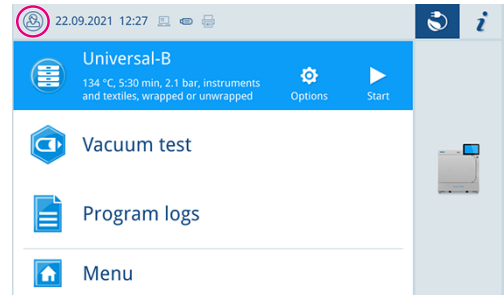

2. Select the desired role, e.g. **Administrator**.

3. Enter the associated PIN.

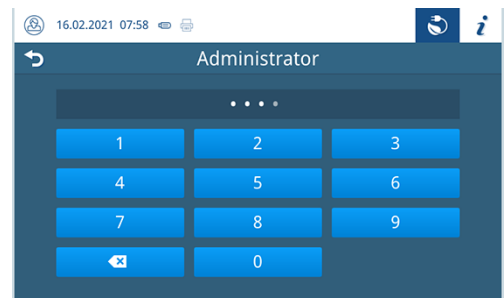

- The symbol of the user role button changes.
- Further setting options are now available in the menu.

### Logging off a user role

In order to log off a user role, proceed as follows:

1. Press the user role button.

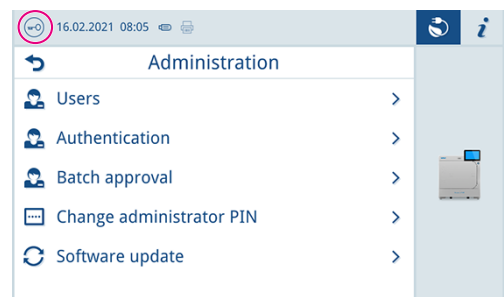

2. Press **LOGOUT**.

- The symbol of the user role button changes.

## Users

An individual ID and user PIN can be issued to every user to facilitate reliable traceability via the approval process after the end of a sterilization program. With the user PIN, the user can authenticate himself before the batch is approved, see [Authentication](#) [▶ page 71].

Only created users are authorised to approve and can approve a batch with their user PIN, see [Batch approval](#) [▶ page 71].

In the **Settings > Administration** you can create or edit users.

The following must be fulfilled or present:

- ✓ The logged-in user role is: **Administrator** or **Service technician**.

1. Select the **Users** menu.

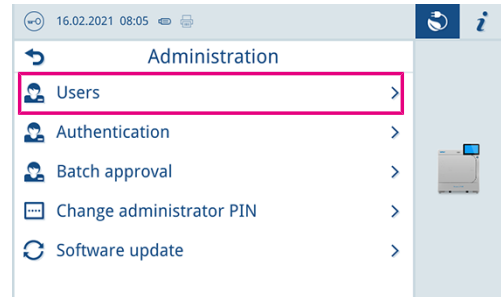

2. Press the plus button (pos. a) to create a new user.

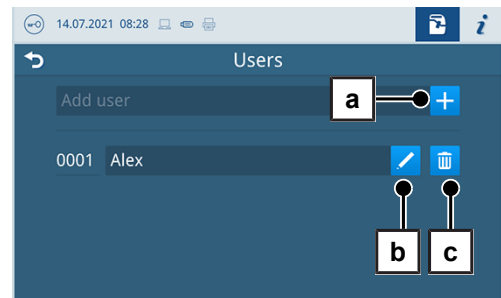

3. Edit (pos. b) or delete (pos. c) the user using the buttons next to the user name.
4. Press the buttons with the pen to change the ID (pos. d), the user name (pos. e) or the PIN (pos. f).

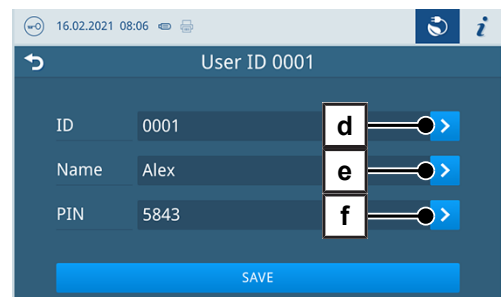

5. Confirm the changes with **OK** and accept the changes with **SAVE**.

**PLEASE NOTE**

You can determine the necessity of user authentication via a PIN in the [Authentication](#) [▶ page 71] menu.

## Authentication

In the **Settings > Administration** menu, you can activate authentication (PIN entry) for the start or end of the program.

The following must be fulfilled or present:

- ✓ The logged-in user role is: **Administrator** or **Service technician**.

1. Select the **Authentication** menu.

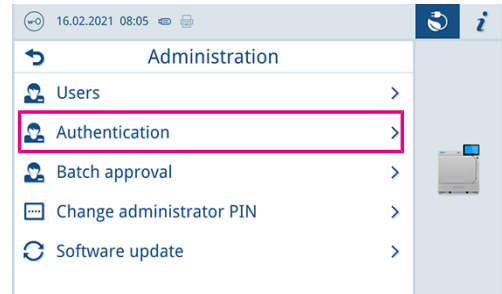

2. Activate or deactivate the desired setting by selecting or deselecting it.

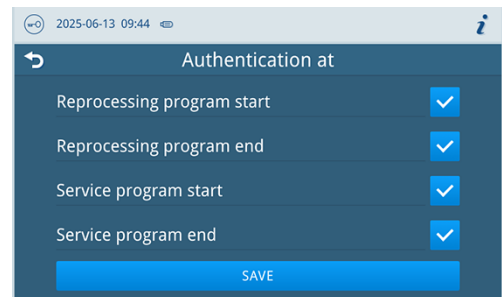

3. Press **SAVE** to accept the changes.

The following settings are possible:

Designation	Description
Reprocessing program start	PIN entry required to start a reprocessing program
Reprocessing program end	PIN entry required to open door after the end of a reprocessing program
Service program start	PIN entry required to start a service program
Service program end	PIN entry required to open door after the end of a service program

**PLEASE NOTE**

All options are disabled in the delivery state.

## Batch approval

In the **Settings > Administration** menu you can activate the batch approval and the indicator assessment.

The following must be fulfilled or present:

- ✓ The logged-in user role is: **Administrator** or **Service technician**.

1. Select the **Batch approval** menu.

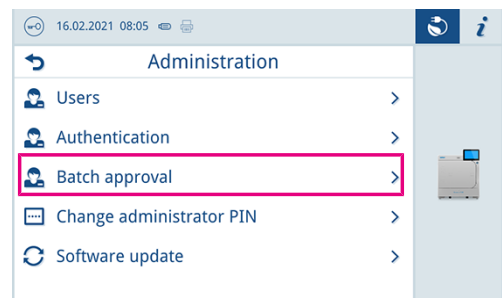

2. Activate or deactivate the desired setting by selecting or deselecting it.

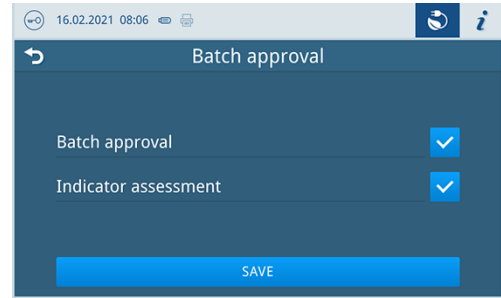

3. Press **SAVE** to accept the changes.

The following settings are possible:

Log type	Description
Batch approval	Batch approval after successful program end
Indicator assessment	Indicator assessment after successful program end

### Changing the administrator PIN

You can change the administrator PIN in the **Settings > Administration** menu.

The administrator PIN (default: 1000) can be edited like every other user PIN and should be changed after delivery.

### Software update

In the menu **Settings > Administration**, you can perform a software update.

**PLEASE NOTE**

During a software update, all program and malfunction logs are deleted.

- Check whether all required logs have been output to an output medium.
- Please observe the further information in the separate instruction “Information regarding software update and re-installation”. You can find the document in the download centre on our website at [www.melag.com/service/downloadcenter](http://www.melag.com/service/downloadcenter).

The following must be fulfilled or present:

- ✓ The logged-in user role is: **Administrator** or **Service technician**.
- ✓ A USB stick in FAT32 format with the current update files
- ✓ All required logs have been output.

1. Select the **Software update** menu.

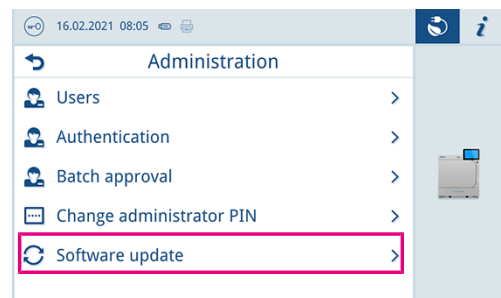

2. Insert the USB stick with the installation data into the USB connection on the display.

3. Press **NEXT** to perform the software update.

➡ During the software update, the device independently performs one or more restarts.

# 13 Maintenance

**PLEASE NOTE**

The maintenance work described below can be performed by the user as part of in-house maintenance.

All maintenance activities beyond this may only be carried out by an **authorised technician**.

## Servicing intervals

Interval	Measure	Device component
Daily	Check the operating media feed water, wastewater	Operating media
	Check the documentation media - printer, network, USB	Documentation media
	Check for soiling, deposits or damage	Sterilization chamber including door gasket and chamber seal face, door lock, mount for the load
Weekly	Check and clean if necessary	All device components (e.g. feed water tank)
	Vacuum test (in the morning before starting work when the device is cold and dry)	Vacuum system
After 2 months	Checking and oiling the door lock	Door mechanism
Annually	Cleaning the tank filter	Feed water tank
After 1000 cycles	Replace the dust filter	Dust filter (behind service hatch)
After 24 months or 4000 cycles	Maintenance	by the authorised customer services working in accordance with the maintenance instructions
As required	Clean the surfaces	Housing parts
	Cleaning and, if necessary, replacement of the suction filter <b>PLEASE NOTE:</b> Only relevant for installation of a filling pump	Suction filter

## Checking and oiling the door lock

**NOTICE**

**Warning of material damage from wear**

If the door lock is not oiled regularly it can become worn. Pressure-tight closing of the door can no longer be ensured.

- Check and oil the door lock every two months.
- Use MELAG oil (included in the scope of delivery) to oil the door lock.

Check and oil the door lock every two months as follows:

1. Clean the locking spindle and nut with a non-fuzzing cloth.
2. Insert the test gauge into the door lock nut as far as it will go and turn it 180°. If this is not possible or resistance can be felt, the door lock nut is worn. Have the door lock nut replaced by an authorised technician.
3. Put two drops of oil in the door lock nut.

➔ The oil will be distributed automatically by closing the door.



## Cleaning

### NOTICE

#### Warning of material damage from incorrect cleaning

Inappropriately performed cleaning can lead to the scratching of and damage to surfaces as well as the development of leaks in sealing faces. This also favours the development of soiling deposits and ▶corrosion in the ▶sterilization chamber.

- Comply with all information regarding cleaning of the parts affected.
- Do not use any hard objects for cleaning such as a metal saucepan cleaner or a wire brush.

### Sterilization chamber, door gasket, mount, trays

To maintain the value of your device and to avoid persistent contamination and deposits, MELAG recommends weekly cleaning of the surfaces. Use the Chamber Protect chamber cleaning set or, if not available, a neutral liquid cleaner or spirit.

**PLEASE NOTE:** Note the instructions for use of the cleaning agent.

The following must be fulfilled or present:

- ✓ Chamber Protect (if not available: neutral liquid cleaner or spirits)
  - ✓ The door is open.
  - ✓ The device is switched off and has cooled down completely.
  - ✓ Trays or sterile containers and the associated mount have been removed from the sterilization chamber.
1. Apply the cleaning agent on a lint-free cloth.
  2. Use a lint-free cloth to uniformly spread the cleaning agent on the surfaces to be cleaned.  
**PLEASE NOTE:** Do not allow cleaning agent to get into the pipes coming from the sterilization chamber.
  3. Allow the cleaning fluid to act and evaporate for a sufficient time. This may take a few minutes.
  4. Wet a new lint-free cloth with plenty of demineralised water.
  5. **NOTICE! Warning of material damage. Residues of cleaning agents can ignite or cause deposits on the instruments. Wipe down the cleaned surfaces thoroughly.**  
After wringing out the cloth, repeat this process if necessary.
  6. Allow the cleaned surfaces to dry completely. This may take a few minutes.
  7. Wipe the cleaned surfaces with a dry, lint-free microfibre cloth.

### Housing parts

Where necessary, clean the housing parts with a neutral fluid cleaner or spirit.

Comply with the following specifications when disinfecting the housing parts:

- Use wipe disinfectants and not spray disinfectants. This prevents disinfectant from getting into inaccessible places or ventilation slots.
- Only use alcohol-based surface disinfectants (ethanol or isopropanol) or alcohol-free disinfectants based on quaternary ammonium compounds.
- Do not use disinfectants containing secondary and tertiary alkylamines or butanone.

### Feed water tank

#### *Drain the feed water tank*

The following must be fulfilled or present:

- ✓ Collection container with a minimum capacity of 5 l
  - ✓ Drain hose (included in the scope of delivery)
  - ✓ The device has been switched off.
1. Open the service hatch.

2. Fit the knob of the drain hose onto the drain valve of the feed water tank until it noticeably latches into position.  
**PLEASE NOTE:** The valve must be in a horizontal position.
3. Place the collection container in front of the device and place the end of the drain hose in the collection container.
4. Open the drain valve by turning the knob of the drain hose 1/4 in an anti-clockwise direction.

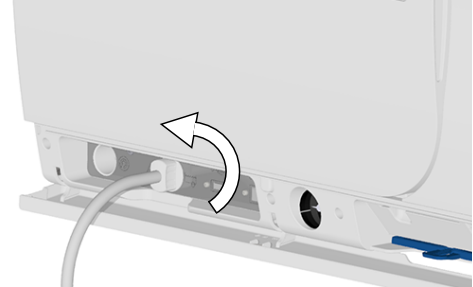

5. Drain the water into the collection container.  
**PLEASE NOTE:** It is advisable to leave the drain hose connected until after the cleaning so that any cleaning fluid residues can be flushed out.

**Clean the feed water tank**

**PLEASE NOTE**

- The cover of the feed water tank is engaged.
- Press the cover backwards before lifting it.

The following must be fulfilled or present:

- ✓ Drain hose (included in the scope of delivery)
- ✓ Solvent-free, non-alkaline cleaning agent (e.g. washing-up liquid)
- ✓ The device has been switched off.
- ✓ The tank is completely empty.

1. Open the cover cap on the top of the device.  
If the cover is difficult to open, let the device cool down.

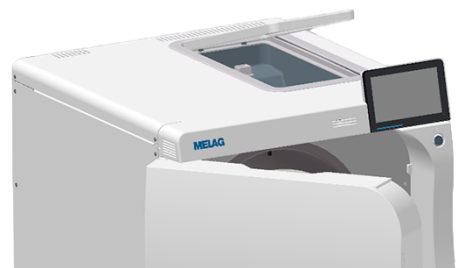

2. Check the tank for soiling and, if necessary, clean it with a sponge and solvent-free, non-alkaline cleaning agent (e.g. washing-up liquid).
3. Rinse any cleaning agent residue with demineralised water.
4. **CAUTION! Warning of burns. The heat exchanger may still be hot even after the device has cooled down. Never touch it with unprotected hands.**  
Fold up the heat exchanger.



- 5. Pull the tank filter out of the bottom of the feed water tank.

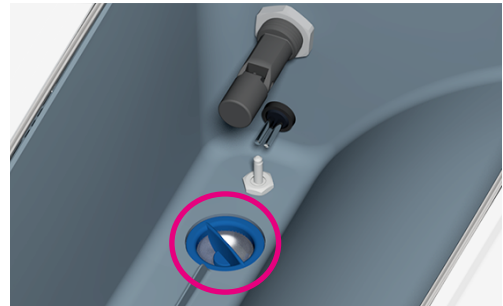

- 6. Clean the tank filter under running water or with the MELAjet spray pistol.
- 7. Check the cleaning result against the light.
- 8. Reinsert the tank filter.
- 9. Reinsert the cover cap correctly and close it.
- 10. To remove the drain hose after cleaning the feed water tank, turn the drain valve back to the horizontal position.
- 11. Close the service hatch.

### Avoiding staining

Only proper cleaning of the instruments prior to sterilization enables you to avoid residue from being released from the load under steam pressure during sterilization. Loosened dirt residue can clog the filter, fittings and valves of the device and deposit themselves on the instruments and in the sterilization chamber as deposits and stains.

All steam-conducting parts of the device consist of non-rusting material. This rules out the development of rust caused by the device. Any rust which develops is always extraneous rust.

Incorrect instrument reprocessing can result in the accretion of rust even on stainless steel instruments of leading manufacturers. Often, a single instrument which drops rust can suffice to cause the development of rust on other instruments or in the device. Remove foreign rust from the instruments using chlorine-free stainless steel cleaning fluid (see [Cleaning](#) [▶ page 74]) or send the damaged instruments to the manufacturer.

The extent of stain accretion on the instruments is also dependant on the [▶feed water](#) used for steam generation.

### Replacing the sterile filter

Comply with the following for safe handling:

- The sterile filter is no longer effective if it has become wet. Stop using the sterile filter and replace it.

The following must be fulfilled or present:

- ✓ A new and dry sterile filter, see [Spare parts](#) [▶ page 93].
- 1. Open the door.
- 2. Pull the sterile filter off the device.
- 3. Insert the new sterile filter.



## Changing the dust filter

The following must be fulfilled or present:

- ✓ A new and clean dust filter, see [Spare parts](#) [▶ page 93]
- 1. Open the service hatch.
- 2. Press down the centre of the grip and pull out the dust filter.



- 3. Insert the new dust filter until it snaps into place. The latch nose of the grip must point upwards.
- 4. Confirm the query with **YES**.
  - ➔ The dust filter counter is reset.
- 5. Close the service hatch.

## Maintenance

Comply with the following for safe handling:

- Maintain the specified maintenance intervals. Continuing operation beyond the maintenance interval can result in malfunctions in the device.
- Have maintenance performed only by trained and authorised technicians using the original MELAG maintenance set.
- If components that are not included in the maintenance set have to be replaced during maintenance, only original spare parts from MELAG may be used for the replacement.

Regular maintenance is vital to ensure reliable operation and value retention of the device. All function and safety-relevant components and electrical units must be checked during maintenance and replaced where necessary.

Maintenance work is to be performed regularly after 4000 program cycles but must be performed after 24 months. The steam sterilizer will issue a maintenance message at the relevant time.

# 14 Pause times

## Duration of the operating pause

Duration of the operating pause	Measure
Short pauses between two sterilization processes	<ul style="list-style-type: none"> <li>• Keep the door closed to save energy</li> <li>• Set Energy-saving as required, see <a href="#">Energy-saving</a> [▶ page 66]</li> </ul>
Pauses which last longer than an hour	<ul style="list-style-type: none"> <li>• Shut down device</li> </ul>
Longer pauses e.g. over night or the weekend	<ul style="list-style-type: none"> <li>• Leave the door ajar to prevent premature wear and the sticking of the door seal</li> <li>• Shut down device</li> <li>• If present, shut off the water inflow of the water treatment unit</li> </ul>
Longer than two weeks	<p><b>Before starting the operating pause:</b></p> <ul style="list-style-type: none"> <li>• Leave the door ajar to prevent premature wear and the sticking of the door seal</li> <li>• Shut down device</li> <li>• If present, shut off the water inflow of the water treatment unit</li> <li>• Empty the internal storage tank</li> <li>• Perform the <b>Draining</b> service program, see <a href="#">Service programs</a> [▶ page 61]</li> </ul> <p><b>Following the operating pause:</b></p> <ul style="list-style-type: none"> <li>• Perform a <b>Vacuum test</b></li> <li>• After a successful vacuum test, perform an empty sterilization in a reprocessing program</li> </ul>

## Decommissioning

When decommissioning the device for a long pause (e.g. due to holiday), proceed as follows:

1. Empty the double jacket steam generator, see [Draining](#) [▶ page 63].
2. Shut down the device by pressing the power button.
3. Disconnect the power plug from the socket and if necessary, allow the device to cool.
4. Empty the internal storage tank via the drain hose.
5. Shut off if present, the water inflow of the water treatment unit.

## Transport

**⚠ CAUTION****Warning of injury**

Lifting and carrying the device incorrectly can cause spinal damage, crushing injuries and bruising.

- Carry the device with at least two people.
- Use the carrying system to carry the device.

**📌 PLEASE NOTE**

Allow [authorised technicians](#) only to transport and install the carrying system.

## Symbols on the packaging



Indicates the temperature limits to which the device can be safely exposed.



Denotes a device that may break or be damaged if handled carelessly.



Indicates a device that must be protected against moisture.



Indicates the upper limit of humidity to which the device can be safely exposed.

## On-site transport

To transport the device within a room or floor, proceed as follows:

1. Decommission the device, see [Decommissioning](#) [▶ page 78].
2. Disconnect the connection hoses connected on the rear of the device.
3. Install the carrying system, see [Installing the carrying system](#) [▶ page 80].

## Off-site transport

To transport the device over longer distances, to different floors or for shipping, proceed as follows:

1. Decommission the device, see [Decommissioning](#) [▶ page 78].
2. Install the carrying system, see [Installing the carrying system](#) [▶ page 80].
3. Pack the device so that it is protected from mechanical hazards (e.g. blows) and moisture.
4. Observe the transport and storage conditions, see [Technical data](#) [▶ page 90].

## Installing the carrying system

1. Undo the three bottom housing screws.
2. Hook the carrying system up into the baseplate.

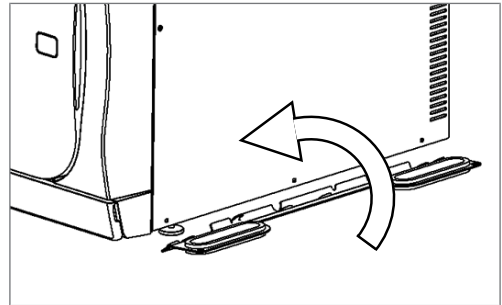

3. Secure the carrying system on the device with the three screws.

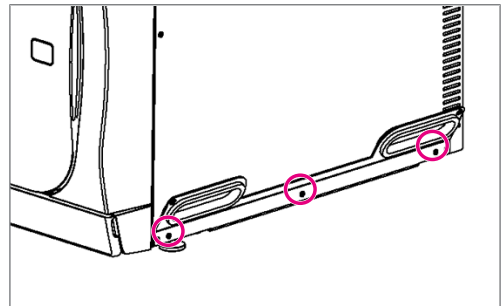



# 15 Malfunctions

Comply with the following for safe handling:

- Should the device issue the same malfunction message repeatedly, turn off the device and if necessary, inform your stockist.
- The device may only be serviced by ► [authorised technicians](#).

Not all notifications on the display are malfunction messages. Warnings and malfunction messages are issued on the display with an event number. This number serves identification purposes.

	Type of message	Description
	Warning	Warnings contain instructions that help you to ensure smooth operation and to identify undesirable states. Comply with these warnings in good time to avoid malfunctions. The reprocessing result is not affected. You can continue to use the device.
	Malfunction message	Malfunction messages are issued when it is not possible to ensure safe operation or safety of sterilization. These can appear on the display shortly after starting up the steam sterilizer or during a program run. If a malfunction occurs during a program run, the program will be aborted.

## Troubleshooting online

All messages with current descriptions can be found in the Troubleshooting portal on the MELAG website (<https://www.melag.com/en/service/troubleshooting>).



### *Before contacting the technical service*

Follow the instructions that appear on the device's display that relate to a warning or malfunction message. The following table contains a summary of the most important events. Should you be unable to find the relevant event, or your efforts do not redress the problem, you can contact your stockist or the MELAG customer service. Have the number of your device, the event number and a detailed description of the malfunction to hand so that we can help you.

## Malfunction logs

In the **Logs > Malfunction logs** menu, you can view malfunction logs and output them to a USB flash drive.

## Warning and malfunction messages

Event	Possible cause	What you can do
10059	The external wastewater container is full.	Empty the external wastewater container before the next program start.
10062	The required amount of feed water was not delivered to the feed water tank within the specified time (70 s).	Ensure the water supply at the main valve, or fill the external storage container when using the filling pump.
10063	The manual feed water supply is activated. The device must be filled with at least 1.5 l of demineralised water.	Before starting the next program, fill the feed water tank with at least 1.5 L of demineralised water or ensure an automatic water supply via a water treatment unit.
10067	The dust filter was removed.	Insert the dust filter (art. no. ME82260).
10071	The running program was terminated by the user.	<b>WARNING! The load is not processed.</b> Restart the program.
10081	The emptying of the double jacket was skipped multiple times because the program was terminated early during drying.	Do not terminate the program early during drying. If this occurs repeatedly, please contact the technical service.
10082	The emptying of the double jacket was skipped multiple times because the program was terminated early during drying.	Start the <b>Draining</b> service program.
10086	The maintenance interval will soon expire (days).	Please contact the technical service and schedule a maintenance appointment.
10090	The warning value of the dust filter counter has been exceeded.	a) Replace the dust filter (art. no. ME82260). b) Confirm the query with YES to reset the dust filter counter.
10091	The maintenance interval will soon expire (cycles).	Please contact the technical service and schedule a maintenance appointment.
10092	The emptying of the double jacket was skipped multiple times because the program was terminated early during drying.	Do not terminate the program early during drying. If this occurs repeatedly, please contact the technical service.
10093	The emptying of the double jacket was skipped multiple times because the program was terminated early during drying.	Start the <b>Draining</b> service program.
10094	The current ambient temperature of the device is too high to perform a vacuum test.	a) Allow the device to cool down. b) Observe the installation and ambient conditions (e.g. temperature, distances) and ensure sufficient ventilation of the device.
10098	A supply voltage failure was detected during the program run.	<b>WARNING! The load is not processed.</b> a) Connect the device to a specially fused power supply to which no other electrical device is connected. b) Check the power connection cable at the rear of the device to ensure that it is firmly seated and put on the safety bracket.
10099	A supply voltage failure was detected during the program run.	<b>WARNING! The load is not processed.</b> a) Connect the device to a specially fused power supply to which no other electrical device is connected. b) Check the power connection cable at the rear of the device to ensure that it is firmly seated and put on the safety bracket.

Event	Possible cause	What you can do
10100	The float switch is jammed due to soiling in the feed water tank. This may cause the feed pump to draw in air.	a) Check the feed water tank for soiling and the float switch for ease of movement. b) Clean both components as described in the User Manual.
10101	The float switch in the overflow funnel (S13) detected a short-term impermissible water level. This points to a blockage in the wastewater system.	Check whether the outlet hose at the rear of the device (hatched drop) is kinked.
10102	The float switch in the overflow funnel (S13) detected a continuous impermissible water level. This points to a blockage in the wastewater system.	Check whether the outlet hose at the rear of the device (hatched drop) is kinked.
10109	The automatic unlocking of the door is faulty. The door locking mechanism or the door motor is possibly blocked.	a) Allow the device to cool down and open the door using the Allen key behind the service hatch. b) Ensure regular oil maintenance of the door spindle and door nut. If this occurs repeatedly, please contact the technical service.
10113	The automatic locking of the door is faulty. The door locking mechanism or the door motor is possibly blocked.	a) Check the door for blockages. b) Ensure regular oil maintenance of the door spindle and door nut. If this occurs repeatedly, please contact the technical service.
10117	The automatic unlocking of the door is faulty. Both door contact switches (K1 + K2) signal a closed door.	a) Allow the device to cool down and open the door using the Allen key behind the service hatch. b) Ensure regular oil maintenance of the door spindle and door nut. If this occurs repeatedly, please contact the technical service.
10120	The automatic unlocking of the door is faulty. The door may be blocked.	a) Allow the device to cool down and open the door using the Allen key behind the service hatch. b) Ensure regular oil maintenance of the door spindle and door nut. If this occurs repeatedly, please contact the technical service.
10125	The door could not be opened completely. One door contact switch (K2) is open, one door contact switch (K1) is closed.	Remove any objects that may be blocking the door from the outside. If this occurs repeatedly, please contact the technical service.
10130	The maximum quantity or duration when feeding feed water into the double jacket has been exceeded.	a) Remove the filter from the feed water tank. b) Clean the filter under running water and re-insert it. If this occurs repeatedly, please contact the technical service.
10132	A pressure equalisation between the sterilization chamber and the environment was not achieved within the specified time.	Check the sterile filter behind the service hatch and replace it if it is soiled or blocked. If this occurs repeatedly, please contact the technical service.

Event	Possible cause	What you can do
10134	The temperature at the cooler could not be lowered sufficiently within the specified time. The cooling system may be faulty.	a) Allow the device to cool down. b) Observe the installation and ambient conditions (e.g. temperature, distances) and ensure sufficient ventilation of the device. If this occurs repeatedly, please contact the technical service.
10137	The maximum permissible pressure was exceeded in the waiting or test phase of the vacuum test.	a) Allow the device to cool down. c) Check the door gasket for visible defects and replace it if necessary. c) Clean the door gasket with a damp cloth. If this occurs repeatedly, please contact the technical service.
10145	The evacuation is faulty. The vacuum was not generated within the specified time.	a) Check the dust filter for contamination and replace it if necessary. b) Check whether paper or similar underneath the device is blocking the air flow of the cooling system. c) Check whether the permissible load quantities of the device have been observed. d) Check the pressure release filter in the sterilization chamber for blockages. e) Observe the installation and ambient conditions (e.g. temperature, distances) and ensure sufficient ventilation of the device. If this occurs repeatedly, please contact the technical service.
10165	The double jacket was not emptied within the specified time.	a) Allow the device to cool down. b) Observe the installation and ambient conditions (e.g. temperature, distances) and ensure sufficient ventilation of the device.
10169	The abort routine was completed with an emergency release. The sterilization chamber can contain hot steam and hot water.	<b>CAUTION! The sterilization chamber can contain hot steam and hot water.</b> Allow the device to cool down. If this occurs repeatedly, please contact the technical service.
10179	The pressure release valve had to be opened several times before a pressure drop occurred.	a) Check the sterilization chamber for any residues from the load or wrapping that may be blocking the nozzles (small openings in the sterilization chamber). b) Check the pressure release filter in the sterilization chamber for blockages.
10184	The external wastewater container is almost full.	Empty the wastewater container before starting a new program. The wastewater container can still receive the wastewater from the currently running program.
10185	The external wastewater container is full.	Empty the external wastewater container.
10186	a) The feed water tank is almost empty. b) The feed water tank is full. A lack of water in the double jacket was detected.	a) Fill the feed water tank. b) Wait until the feed pump stops pumping. Then fill the feed water tank again.
10224	The feed water tank is almost empty.	Before starting the next program, fill the feed water tank up to the maximum mark (MAX) of the level increase or ensure an automatic water supply via a water treatment unit.

Event	Possible cause	What you can do
10226	The feed water tank is almost empty.	Before starting the next program, fill the feed water tank up to the maximum mark (MAX) of the level increase with demineralised water or ensure an automatic water supply via a water treatment unit.
10241	The evacuation is faulty. The vacuum performance is insufficient. The program run was cancelled.	a) Check the dust filter for contamination and replace it if necessary. b) Check whether paper or similar underneath the device is blocking the air flow of the cooling system. c) Check whether the permissible load quantities of the device have been observed. d) Check the pressure release filter in the sterilization chamber for blockages. e) Observe the installation and ambient conditions (e.g. temperature, distances) and ensure sufficient ventilation of the device. If this occurs repeatedly, please contact the technical service.
10242	The evacuation is faulty. The vacuum performance is insufficient. The program run was cancelled.	a) Check the dust filter for contamination and replace it if necessary. b) Check whether paper or similar underneath the device is blocking the air flow of the cooling system. c) Check whether the permissible load quantities of the device have been observed. d) Check the pressure release filter in the sterilization chamber for blockages. e) Observe the installation and ambient conditions (e.g. temperature, distances) and ensure sufficient ventilation of the device. If this occurs repeatedly, please contact the technical service.
10250	A Carebox Green has been detected. This is not compatible with the selected program.	a) Use the Carebox Blue. b) Check the compressed air supply. 4-8 bar rel. should be available.
10256	The pressure change at the pressure sensor (S1) is too low during evacuation. The vacuum was not generated within the specified time.	a) Check the dust filter for contamination and replace it if necessary. b) Check whether paper or similar underneath the device is blocking the air flow of the cooling system. c) Check whether the permissible load quantities of the device have been observed. d) Check the pressure release filter in the sterilization chamber for blockages. e) Observe the installation and ambient conditions (e.g. temperature, distances) and ensure sufficient ventilation of the device. If this occurs repeatedly, please contact the technical service.

Event	Possible cause	What you can do
10257	The pressure change at the pressure sensor (S1) is too low during evacuation. The vacuum was not generated within the specified time.	a) Check the dust filter for contamination and replace it if necessary. b) Check whether paper or similar underneath the device is blocking the air flow of the cooling system. c) Check whether the permissible load quantities of the device have been observed. d) Check the pressure release filter in the sterilization chamber for blockages. e) Observe the installation and ambient conditions (e.g. temperature, distances) and ensure sufficient ventilation of the device. If this occurs repeatedly, please contact the technical service.
10266	A drop in vacuum performance has been detected.	a) Check the dust filter for contamination and replace it if necessary. b) Check whether paper or similar underneath the device is blocking the air flow of the cooling system. c) Check whether the permissible load quantities of the device have been observed. d) Check the pressure release filter in the sterilization chamber for blockages. e) Observe the installation and ambient conditions (e.g. temperature, distances) and ensure sufficient ventilation of the device. If this occurs repeatedly, please contact the technical service.
10267	A drop in vacuum performance has been detected.	a) Check the dust filter for contamination and replace it if necessary. b) Check whether paper or similar underneath the device is blocking the air flow of the cooling system. c) Check whether the permissible load quantities of the device have been observed. d) Check the pressure release filter in the sterilization chamber for blockages. e) Observe the installation and ambient conditions (e.g. temperature, distances) and ensure sufficient ventilation of the device. If this occurs repeatedly, please contact the technical service.
10268	A decreasing steam inlet speed was detected.	Check whether the permissible load quantities of the device have been observed. If this occurs repeatedly, please contact the technical service.
10269	A decreasing speed during ventilation was detected.	Check the sterile filter behind the service hatch and replace it if it is soiled or blocked. If this occurs repeatedly, please contact the technical service.

Event	Possible cause	What you can do
10270	A decreasing speed during pressure release was detected.	<p>a) Check the dust filter for contamination and replace it if necessary.</p> <p>b) Check whether paper or similar underneath the device is blocking the air flow of the cooling system.</p> <p>c) Check whether the permissible load quantities of the device have been observed.</p> <p>d) Check the pressure release filter in the sterilization chamber for blockages.</p> <p>e) Observe the installation and ambient conditions (e.g. temperature, distances) and ensure sufficient ventilation of the device.</p> <p>If this occurs repeatedly, please contact the technical service.</p>
10271	The conductivity of the feed water is poor ( $\leq 40 \mu\text{S/cm}$ ). A program start is still possible.	Replace the water in the feed water tank without delay or restore the capacity of the water treatment unit in accordance with the user manual.
10273	The conductivity of the feed water is insufficient ( $\leq 60 \mu\text{S/cm}$ ). A program start is not possible.	Replace the water in the feed water tank without delay or restore the capacity of the water treatment unit in accordance with the user manual.
10275	The water inlet into the double jacket is too low ( $\leq 120 \text{ ml/min}$ ).	<p>a) Remove the filter from the feed water tank.</p> <p>b) Clean the filter under running water and re-insert it.</p> <p>If this occurs repeatedly, please contact the technical service.</p>
10283	The vacuum was built up too quickly. The vacuum performance is too high. The program run was cancelled.	<p>a) Check the dust filter for contamination and replace it if necessary.</p> <p>b) Check whether paper or similar underneath the device is blocking the air flow of the cooling system.</p> <p>c) Check whether the permissible load quantities of the device have been observed.</p> <p>d) Check the pressure release filter in the sterilization chamber for blockages.</p> <p>e) Observe the installation and ambient conditions (e.g. temperature, distances) and ensure sufficient ventilation of the device.</p> <p>If this occurs repeatedly, please contact the technical service.</p>

Event	Possible cause	What you can do
10286	The vacuum was built up too quickly. The vacuum performance is too high. The program run was cancelled.	<p>a) Check the dust filter for contamination and replace it if necessary.</p> <p>b) Check whether paper or similar underneath the device is blocking the air flow of the cooling system.</p> <p>c) Check whether the permissible load quantities of the device have been observed.</p> <p>d) Check the pressure release filter in the sterilization chamber for blockages.</p> <p>e) Observe the installation and ambient conditions (e.g. temperature, distances) and ensure sufficient ventilation of the device.</p> <p>If this occurs repeatedly, please contact the technical service.</p>
11000	The connected USB stick was not recognised. It may not be correctly formatted.	<p>a) Format the USB stick using the FAT file system.</p> <p>b) Replace the USB stick if the message continues to appear.</p>
11001	Multiple USB sticks are connected. Only one USB stick is supported.	Remove all USB sticks except one.
11002	No USB stick is connected.	Connect a USB stick to the interface behind the service hatch.
11003	There is not enough free space on the USB stick for the required log data.	<p>a) Transfer the logs from the USB stick to your computer.</p> <p>b) Delete the saved logs from the USB stick to create memory space for the new logs.</p>
11004	The output of the log data on the USB stick has failed.	Connect a USB stick to the interface behind the service hatch.
11006	The maximum number of program logs not output has been reached. The oldest log will be overwritten during the next program run.	<p>a) Transfer the internally stored logs to a USB stick or into your practice network.</p> <p>b) Alternatively, configure automatic log output in the settings menu.</p>
11007	The printer cover was open while a print job was being sent.	Close the printer cover.
11008	The label roll in the printer is used up.	Load a new label roll into the printer.
11009	A printer is configured but not connected.	<p>a) Connect a printer to the network interface on the back of the device.</p> <p>b) Restart the device.</p> <p>c) Restart the printer.</p>
11011	Multiple printers are connected. Only one printer is supported.	<p>a) Remove all printers except one.</p> <p>b) Restart the device.</p> <p>c) Restart the printer.</p>
11012	The label roll in the printer is almost used up.	Hold a new label roll ready.
11013	General printer error.	<p>a) Restart the device.</p> <p>b) Restart the printer.</p>
11100	The log output was cancelled due to a connection error.	Check the network interface at the back of the device.

Event	Possible cause	What you can do
14137	An actuator/sensor error has occurred.	<p>In case of malfunction (open load) at ACOUT 1 and 2:                      Press the reset button of the overheating protection behind the service hatch.</p> <p>If this occurs repeatedly, please contact the technical service and state which sensor/ actuator is affected by the malfunction.</p>
14138	An actuator/sensor error has occurred.	<p>In case of malfunction (open load) at ACOUT 1 and 2:                      Press the reset button of the overheating protection behind the service hatch.</p> <p>If this occurs repeatedly, please contact the technical service and state which sensor/ actuator is affected by the malfunction.</p>
19999	A software error has occurred.	<p>Restart the device by pressing the Power button and keeping it pressed for several seconds.</p> <p>If this occurs repeatedly, please contact the technical service.</p>

## 16 Technical data

<b>Device type</b>	<b>Vacuclave 550</b>
Device dimensions (H x W x D)	65.0 x 63.6 x 71.5 cm
Empty weight	98 kg
Operating weight	127 kg
Floor loading (normal operation)	2.71 kN/m <sup>2</sup>
Floor loading (pressure resistance test)	3.53 kN/m <sup>2</sup>
<b>Sterilization chamber</b>	
Diameter	38 cm
Depth	45 cm
Volume (chamber / steam generator)	53 l/12.5 l
<b>Electrical connection</b>	
Power supply	220-230 V, 50/60 Hz
Max. voltage range	198-255 V
Electrical power	3400 W (15 A operation) 2700 W (13 A operation)
Building fuse	16 A, RCD 30 mA (15 A operation) 13 A, RCD 30 mA (13 A operation)
Length of the power cable	2 m
Overvoltage category (in accordance with EN 61010-1)	transient overvoltages up to the values of overvoltage category II
Degree of contamination (in accordance with EN 61010)	2
<b>Ambient conditions</b>	
Installation location	interior of a building (dry and protected from dust)
Installation surface	level, horizontal and waterproof/sealed
Noise emission LP(a) in 1 m distance	57.6 dB(A)
Heat emission (with max. load)	2.25 kWh
Ambient temperature	5-40 °C (ideal range 16-26 °C)
Relative humidity	max. 80 % at temperatures of up to 31 °C, max. 50 % at 40 °C (decreasing in linear fashion in-between)
Degree of protection (in accordance with IEC 60529)	IP20
Transport and storage conditions	temperature: -18 to +50 °C, air humidity: < 80%
Max. altitude	3000 m
<b>Feed water</b>	
Max. water consumption	5.5 l/cycle
Average water consumption	2 l/cycle
Water temperature	5-35 °C (ideal 15-20 °C)
Min. flow pressure	0.5 bar at 1.0 l/min
Min. static water pressure	1 bar
Max. static water pressure	10 bar
Water quality	distilled or demineralised water in accordance with EN 13060, Appendix C

<b>Cold water (when using a water treatment unit)</b>	The technical data for the cold water can be found in the user manual of the relevant water treatment unit.
<b>Wastewater</b>	
Max. throughflow volume	2 l/min
Max. water temperature	90 °C for 30 seconds, maximum 98 °C for 1 second
<b>Working and operating pressures</b>	
Permitted operating pressure, sterilization chamber	-1 bar to +3 bar relative
Permitted operating pressure jacket	-1 bar to +3 bar relative
Working pressure sterilization chamber/ double jacket steam generator	2.2 bar relative

# 17 Components, accessories and spare parts

You can obtain the specified articles and an overview of further accessories from your stockist.

## Components

Category	Article	Art. no.
Mounts	Comfort mount	ME22485
	Basic mount	ME22486
	Loading slide	ME22606
Trays	Tray short standard (29 x 19 cm)	ME00280
	Tray long standard (42 x 19 cm)	ME00230
	Tray (41 x 29 cm)	ME00550
Package holder	Package holder, short (18.4 x 28 x 8.7 cm)	ME22410
	Package holder, long (18.4 x 37 x 8.7 cm)	ME22420

## Accessories

Category	Article	Art. no.
Sterilization container with single-use paper filters in accordance with EN 868-8 (depth x width x height)	15K (18 x 12 x 4.5 cm)	ME01151
	15M (35 x 12 x 4.5 cm)	ME01152
	15G (35 x 12 x 8 cm)	ME01153
	17K (20 x 14 x 5 cm)	ME01171
	17M (41 x 14 x 5 cm)	ME01172
	17G (41 x 14 x 9 cm)	ME01173
	23M (42 x 16 x 6 cm)	ME01231
	23G (42 x 16 x 12 cm)	ME01232
	28M (32 x 16 x 6 cm)	ME01284
	28G (32 x 16 x 12 cm)	ME01285
Films	MELAfol 501 (pouch, 5 x 25 cm, 1000 pcs.)	ME00501
	MELAfol 502 (roll, 5 cm x 200 m)	ME00502
	MELAfol 751 (pouch, 7.5 x 25 cm, 1000 pcs.)	ME00751
	MELAfol 752 (roll, 7.5 cm x 200 m)	ME00752
	MELAfol 1001 (pouch, 10 x 25 cm, 1000 pcs.)	ME01001
	MELAfol 1002 (roll, 10 cm x 200 m)	ME01002
	MELAfol 1502 (roll, 15 cm x 200 m)	ME01502
	MELAfol 2002 (roll, 20 cm x 200 m)	ME02002
	MELAfol 2051 (side gusset bag, 20 x 50 cm, 100 pcs.)	ME02051
	MELAfol 2502 (roll, 25 cm x 200 m)	ME02502
MELAstore System	MELAstore Box 100 (31.2 x 19 x 4.6 cm)	ME01191
	MELAstore Box 200 (31.2 x 19 x 6.5 cm)	ME01192

**Other equipment**

Category	Article	Art. no.
Test body systems	SteriHero Helix	ME01084
	MELAcontrol Helix	ME01082
	MELAcontrol Pro (incl. 40 indicator strips)	ME01075
	MELAcontrol Pro refill pack (250 pcs. incl. seal)	ME01076
	MELAcontrol type 5 indicator (250 pcs.)	ME01077
	MELAcontrol Bowie & Dick test (1 pc.)	ME01078
Water treatment	MELAdem 47 reverse osmosis unit	ME01047
	Pressure increase pump for MELAdem 47	ME22500
	MELAdem 53 with 2 containers (20 l each)/MELAdem 53 C with 2 containers (15 l each)	ME01038/ ME01036
Water supply	Water stop (leakage water detector with shut-off valve and probe)	ME01056
	Filling pump	ME65010
Water disposal	Tank drain hose, complete	ME53002
	Wastewater container	ME65020
	Surface-mounted siphon	ME37410
	Wastewater via pressure release conversion set	ME09044
Door	Allen key for door emergency opening	ME36810
	Test gauge TR20 for door lock nut	ME27521
Documentation	MELAG USB stick	ME19901
	MELAprint 60 label printer	ME01160
	MELAprint 80 universal printer	ME01108
	Network cable, 2.5 m	ME15817
	Network cable, 5 m	ME15814
	Network cable, 10 m	ME15815
Other	Fast Ethernet Switch	ME76600
	Carrying system	ME80025
	Tray lifter	ME28888
	Heat protection gloves	ME89600
	Chamber Protect chamber cleaning set	ME01081
	Wastewater via pressure release conversion set	ME09044

**Spare parts**

Article	Art. no.
Dust filter	ME82260
Sterile filter	ME20160
Feed water tank filter	ME21358
Tank cover	ME80067
MELAG oil for door lock nut	ME27515
Carrying system	ME80025
Power cable C21 type E+F	ME21301
Power cable C21 Type J (SEV) (Switzerland)	ME21302
Power cable C21 Type I (AS3112) (Australia)	ME21303
Power cable C21 Type I (GB2099-1/GB1002) (China)	ME21304
Power cable C21 Type G (United Kingdom)	ME21305
Power cable C21, type CEE16, blue	ME21306
Power cable C21 Type K (Denmark)	ME21307
Power cable C21 Type H (Israel)	ME21308



# 18 Technical tables

## Feed water quality

Minimum requirements to the feed water following EN 13060, Appendix C

Substance/property	Feed water
Evaporation residue	≤ 10 mg/l
Silicon oxide, SiO <sub>2</sub>	≤ 1 mg/l
Iron	≤ 0.2 mg/l
Cadmium	≤ 0.005 mg/l
Lead	≤ 0.05 mg/l
Traces of heavy metal apart from iron, cadmium, lead	≤ 0.1 mg/l
Chloride	≤ 2 mg/l
Phosphate	≤ 0.5 mg/l
▶pH value	5 - 7.5
Appearance	≤ colourless, clear, without sediments
Hardness	≤ 0.02 mmol/l

## Precision and drift behaviour

### Sensors

#### Temperature sensors

Sensor type	PT 1000 Class A according to DIN EN 60751
Precision (at 135 °C)	± 0.42 K
Drift per year	± 0.05 K
Drift in 5 years	± 0.25 K

#### Pressure sensor

Sensor type	Piezoresistant absolute pressure sensor 0 to 4000 mbar
Precision	± 0.3 % corresponds to ± 12 mbar corresponds to approx. ± 0.13 K steam
Drift per year	± 0.2 % corresponds to ± 8 mbar corresponds to approx. ± 0.09 K steam
Drift in 5 years	± 1.0 % corresponds to ± 40 mbar corresponds to approx. ± 0.44 K steam

### Measuring chains

#### Measuring chain for the temperature measurement on the electronics (without sensor)

Precision (at 135 °C)	± 0.2 K
Drift per year	± 0.005 K
Drift in 5 years	± 0.025 K

#### Measuring chain for the pressure measurement on the electronics (without sensor)

Precision	± 0.2 % corresponds to ± 8.0 mbar corresponds to approx. ± 0.09 K steam
Drift per year	± 0.004 % corresponds to ± 0.16 mbar corresponds to approx. ± 0.017 K steam
Drift in 5 years	± 0.02 % corresponds to ± 0.8 mbar corresponds to approx. ± 0.09 K steam



## After 1 year

### Entire measurement sequence of temperature measurement

Precision (at 135 °C)	at pure addition of indiv. malfunctions approx. $\pm 0.70$ K
	according to Gauss's law of propagation approx. $\pm 0.47$ K

### Entire measurement sequence of pressure measurement

Precision	at pure addition of indiv. errors	$\pm 0.70$ % corresponds to $\pm 28.0$ mbar corresponds to approx. $\pm 0.30$ K steam temperature
	per Gaussian law of propagation	$\pm 0.41$ % corresponds to $\pm 16.5$ mbar corresponds to approx. $\pm 0.18$ K steam temperature

## After 5 years

### Entire measurement sequence of temperature measurement

Precision (at 135 °C)	at pure addition of indiv. malfunctions approx. $\pm 0.70$ K
	according to Gauss's law of propagation approx. $\pm 0.47$ K

### Entire measurement sequence of pressure measurement

Precision	at pure addition of indiv. errors	$\pm 0.70$ % corresponds to $\pm 28.0$ mbar corresponds to approx. $\pm 0.30$ K steam temperature
	per Gaussian law of propagation	$\pm 0.41$ % corresponds to $\pm 16.5$ mbar corresponds to approx. $\pm 0.18$ K steam temperature

## Nominal value tolerances

Step			Universal-B	Prion-B	Gentle-B	Quick-S	Program phase
	P [mbar <sub>a</sub> ]	T [°C]	Pressure P) / Temperature (T) tolerance				
SP-S	--	--	--	--	--	--	Program start
SV1	c 500	--	x	x	x	x	Pre-evacuation
SK13	c 1500	--	x	x	x	x	Steam inlet sterilization chamber
SH1	c 1500	--	x	x	x	x	Conditioning hold
SF2	c 500	--	x	x	x	x	Fractionation evacuation
SK11	c 1900	--	+100/-20	+100/-20	c 1800	c 1800	Conditioning steam inlet
SK12	c 1900	--	+100/-500	+100/-500	c 1800	◀	Conditioning hold
SK13	c 1300	--	+20/-50	+20/-50	◀	◀	Conditioning pressure release
SF12	c 300	--	+30/-30	+30/-30	◀	c 225	Fractionation evacuation
SF13	c 2100	--	+100/-20	+100/-20	c 1800	--	Fractionation steam inlet
SF21	c 1300	--	+20/-50	+20/-50	◀	◀	Fractionation pressure release



Step			Universal-B	Prion-B	Gentle-B	Quick-S	Program phase
	P [mbar <sub>a</sub> ]	T [°C]	Pressure P) / Temperature (T) tolerance				
SF22	c 200	--	+30/-30	+30/-30	◀	c 150	Fractionation evacuation
SF23	c 2100	--	+100/-20	+100/-20	c 1800	x	Fractionation steam inlet
SF31	c 1300	--	+20/-50	+20/-50	◀	x	Fractionation pressure release
SF32	c 500	--	+30/-30	+30/-30	◀	x	Fractionation evacuation
SF33	c 2000	--	+100/-20	+100/-20	c 1500	◀	Fractionation steam inlet
SH1	c 2950	--	+60/-60	+60/-60	c 1850	◀	Hold steam inlet
SH2	c 2950	--	+60/-60	+60/-60	c 1950	◀	Hold control
SS1	c 3031	c 134	+60/-60	+60/-60	c 2080	◀	Sterilization entry
SS2	c 3170	c 135.3	+60/-60	+60/-60	c 2150	◀	Sterilization
SA2	c 1943	--	+60/-60	+60/-60	◀	◀	Pressure release
VAT	c 190	--	+60/-60	+60/-60	x	x	Drying evacuation
TDL	c 741	--	+60/-60	+60/-60	x	x	Drying compressed air
ST12	c 80	--	--	--	--	--	Drying hold
ST13	c 180	--	--	--	--	--	Drying ventilation
ST21	c 80	--	--	--	--	--	Drying evacuation
ST22	c 80	--	--	--	--	--	Drying hold
ST23	c 180	--	--	--	--	--	Drying ventilation
ST31	c 80	--	--	--	--	--	Drying evacuation
ST32	c 80	--	--	--	--	--	Drying hold
SB12	c *)	--	--	--	--	--	Ventilation
SP-E	--	--	x	x	x	x	Program end

**Key:**

◀ as in the Universal-B  
 -- not specified  
 c chamber

\*) Ambient pressure  
 x not applicable  
 --



### Pressure-time chart

Pressure-time diagram for Universal-B, 134 °C and 2.1 bar

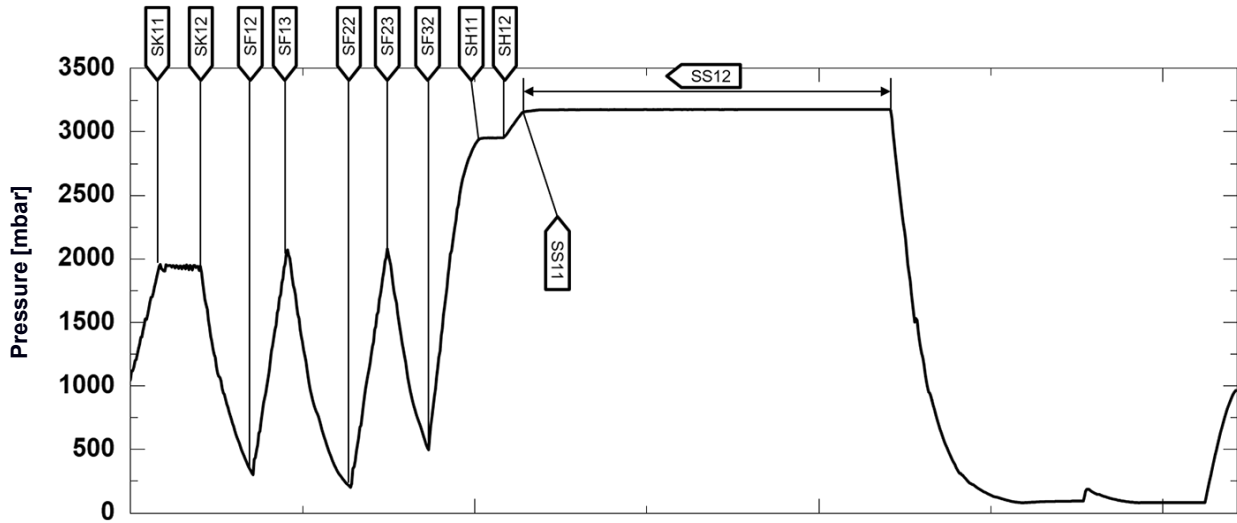

Pressure-time diagram for Quick-S, 134 °C and 2.1 bar

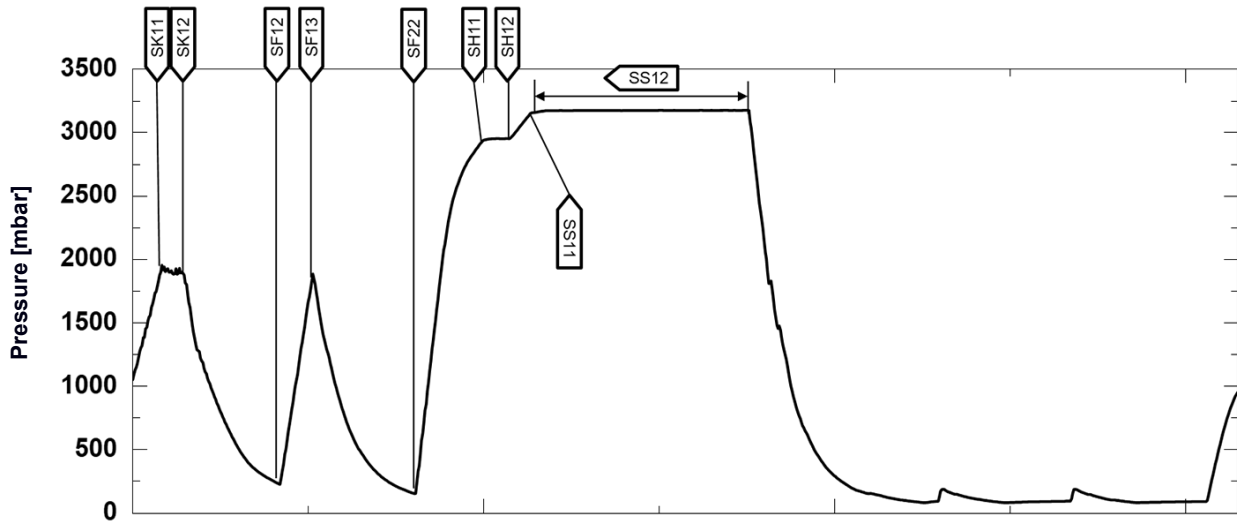



Pressure-time diagram for Prion-B, 134 °C and 2.1 bar

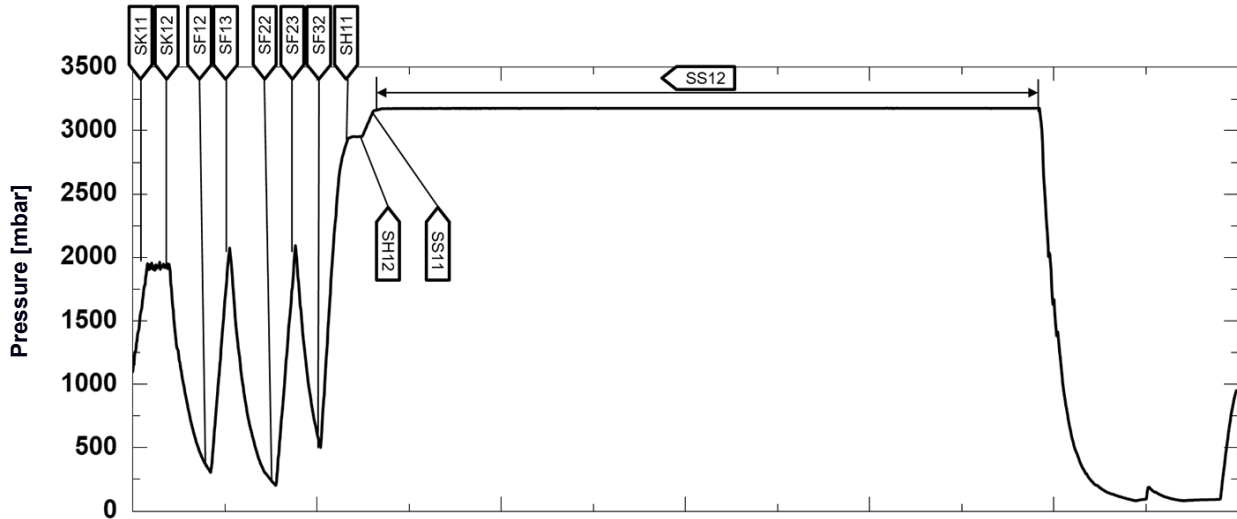

Pressure-time diagram for Gentle-B, 121 °C and 1.1 bar

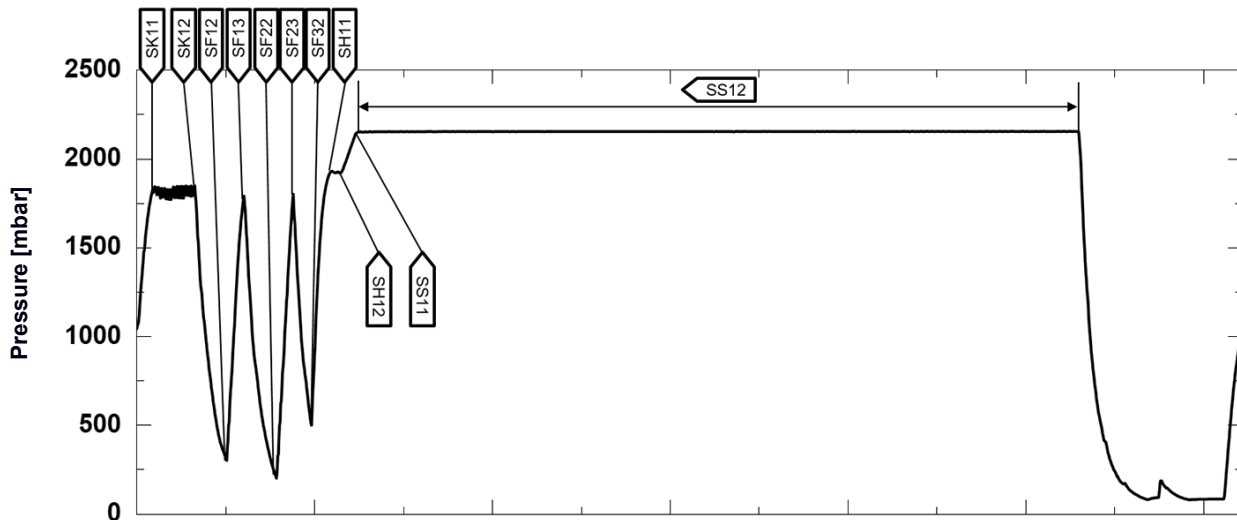

### Empty chamber test

The coldest point in the sterilization chamber during the empty chamber test lies directly on the temperature sensor (see blue dot in the following figure). The temperature in the remaining three area of the sterilization chamber is almost the same all over (0.8 K range).

Schematic side and fore view of the sterilization chamber

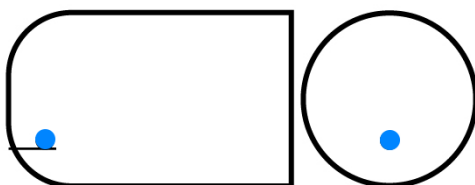

## Glossary

### **Accessory**

Accessories are independent articles that are used with one or several medical devices. Accessories specifically and directly assist the intended purpose of the medical device.

### **Air leakage**

An air leakage is a location through which air can pass in or out without this being desired. The verification of the leakage serves to prove that the volume of air ingress in the sterilization chamber during the vacuum phase does not exceed a value which would prevent steam penetration of the load and that the air leakage does not cause the possible contamination of the load during the drying phase.

### **AKI**

AKI is the abbreviation for "Arbeitskreis Instrumentenaufbereitung" [Instrument Reprocessing Working Group].

### **Authorised technician**

An authorised technician is a person intensively trained and authorised by MELAG who has sufficient specific device and technical knowledge, to perform maintenance and installation work on MELAG devices. Only they may carry out this work.

### **Batch**

The batch is the composition of items which has been subject to the same reprocessing procedure.

### **BfArM**

BfArM is the abbreviation for "Bundesinstitut für Arzneimittel und Medizinprodukte" [Federal Institute for Drugs and Medical Devices] in Germany.

### **Bowie & Dick test**

The Bowie & Dick test is a vapour penetration test with standard test package, see EN 285. This test is recognised in large-scale sterilization.

### **Competent personnel**

Trained personnel in accordance with national specifications for the respective area of application (dentistry, medicine, podiatry, veterinary medicine, cosmetics, piercing, tattoo) with the following contents: knowledge of instruments, hygiene and microbiology, risk assessment and classification of medical devices and instrument reprocessing.

### **Component**

A component is a part of a medical device, which is delivered with it but is not permanently connected to it. A component supports or achieves the intended purpose of the medical device for at least one use case. It is not an independent accessory or medical device.

### **Condensate**

Condensate is a liquid (e.g. water) that emerges from the vapour state when cooled and thus separates.

### **Conductivity**

Conductivity is the ability of a conductive chemical substance or mixture of substances to conduct or transfer energy or other substances or particles in space.

### **Corrosion**

Corrosion is the chemical alteration or destruction of metallic materials by water and chemical substances.

### **Delay in boiling**

Superheating is the phenomenon that it is possible under certain circumstances to heat liquids beyond their boiling point without them boiling. This condition is unstable. Low-level agitation can produce a large bubble within the shortest period; this can expand explosively.

### **Demineralised water**

Demineralised water does not contain minerals that are found in normal spring or tap water. It is obtained from tap water by ion exchange and used as feed water.

### **DGSV**

DGSV is the abbreviation for "Deutsche Gesellschaft für Sterilgutversorgung" [German Society for Sterile Supply]. The training guidelines of the DGSV are listed in DIN 58946, Part 6 as requirements for personnel.

### **DGUV Regulation 1**

DGUV is the abbreviation for "Deutsche Gesetzliche Unfallversicherung" [German Statutory Accident Insurance]. The regulation 1 governs the principles of prevention.

### **DIN 58946-7**

Standard for "Sterilization – Steam sterilizers – Part 7: Building requirements and requirements placed on the equipment and the operation of steam sterilizers in the health-care branch"

### **DIN 58953**

Standard for "Sterilization – Sterile supply"

### **Distilled water**

Distilled water is largely free of salts, organic substances, and micro-organisms. It is obtained by distillation (evaporation and subsequent condensation) from normal tap water or pre-purified water. Distilled water is used as feed water.

### **Dynamic pressure test**

The dynamic pressure test serves to prove that the rate of pressure variations in the sterilization chamber during a sterilization cycle does not exceed a particular value which could result in the damage of the packaging material, see EN 13060.

**Empty chamber test**

The empty chamber test is a test without a load and is performed to assess the performance of the steam sterilizer without the influence of a load. This allows the temperatures and pressures obtained to be checked against the intended settings, see EN 13060.

**EN 13060**

Standard for "Small steam sterilizers"

**EN ISO 11140-1**

Standard for "sterilization of products for use in medical treatment – chemical indicators – part 1: General requirements"

**EN ISO 11607-1**

Standard for "packaging for medical devices to be sterilized in the final packaging – Part 1: Requirements placed on materials, sterile barrier systems, and packaging systems"

**Equipment**

Equipment is an article that can be used with the medical device, however, it is not necessary for assisting and/or achieving the intended purpose of the medical device. It is not an independent accessory or medical device.

**Evacuation**

Evacuation is the creation of a vacuum in a vessel.

**Feed water**

Feed water is required to generate the water vapour for sterilization; guide values for water quality in accordance with EN 285 or EN 13060 – Appendix C.

**Fractionated vacuum procedure**

The fractionated vacuum process is a technical process of steam sterilization. This procedure includes the repeated evacuation of the sterilization chamber in alternation with steam injection.

**FTP**

FTP (File Transfer Protocol) is a data transmission procedure serving to transfer data from the Internet. This data can include programs, files or even information. Special FTP programs (FTP clients) serve to load the data onto a server.

**IEC 61326-1**

Standard for "Electrical equipment for measurement, control and laboratory use - EMC requirements - Part 1: General requirements"

**KRINKO**

KRINKO is the abbreviation for "Kommission für Krankenhaushygiene und Infektionsprävention" [Commission for Hospital Hygiene and Infection Prevention] at the Robert Koch Institute in Germany.

**Load**

The load includes products, equipment, or materials that are reprocessed together in one operating cycle.

**Medical device**

Medical device means any instrument, apparatus, appliance, software, implant, reagent, material or other article intended by the manufacturer to be used, alone or in combination, for human beings for one or more of the specific medical purposes in accordance with Regulation (EU) 2017/745 Article 1, Paragraph 4.

**Mixed loads**

The load within a batch includes both packed and unpacked products.

**Multiple wrapping**

The load is sealed in a double layer of film, instruments wrapped in foil are additionally planed in a container or containers wrapped in textiles.

**pH Value**

The pH value is a measure of the strength of the acid or alkali effect of a watery solution.

**Porous**

Porous describes the property of materials (e.g. textiles) to allow water, air, or other liquids to pass through.

**Porous full load**

The porous full load specification serves to prove that the values set at the control satisfy the necessary sterilization conditions in porous loads with the maximum density for whose sterilization a steam sterilizer is designed to EN 13060.

**Porous partial load**

The porous partial load specification serves to prove that the values set on the control allow steam to enter the pre-determined test package quickly and equally, see EN 13060.

**Pre-heating time**

The preheating time is the time required for preheating the double-jacket steam generator after starting up the device or after starting a reprocessing program before the sterilization process starts. The duration depends on the sterilization temperature.

**Process evaluation system**

The process evaluation system (also known as "self-monitoring system") monitors itself and compares sensors during running programs.

**Product with narrow lumen**

A product with narrow lumen is either open on one side or on both sides. The following applies for an article open on one side:  $1 \leq L/D \leq 750$  and  $L \leq 1500$  mm. The following applies for an article open on both sides:  $2 \leq L/D \leq 1500$  and  $L \leq 3000$  mm and which does not correspond to the hollow body B ( $L$  = hollow body length,  $D$  = hollow body diameter), see EN 13060.

**Qualified electrician**

The qualified electrician has the suitable technical training, knowledge, and experience to recognise and avoid hazards that can be caused by electricity, see IEC 60050 or for Germany VDE 0105-100.

**Reprocessing**

Reprocessing is a measure to prepare a new or used healthcare device for its intended purpose. Reprocessing includes cleaning, disinfection, sterilization and similar procedures.

**RKI**

RKI is the abbreviation for "Robert Koch-Institut" [Robert Koch Institute]. The Robert Koch Institute is the central institution for the detection, prevention, and control of diseases, especially infectious diseases.

**Simple hollow bodies**

A simple hollow body is either open on one side or both sides, see EN 13060. The following applies for an article open on one side:  $1 \leq L/D \leq 5$  and  $D \geq 5$  mm. The following applies for an article open on both sides:  $2 \leq L/D \leq 10$  and  $D \geq 5$  (L = hollow body length, D = hollow body diameter).

**Single wrapping**

The load is wrapped once in a sterile barrier system (e.g. transparent sterilization package). The opposite of this is multiple wrapping.

**Soft sterilization packaging**

A soft sterilization wrapping is a paper bag or a transparent sterilization package.

**Solid**

Solid describes the property of a product that is made of non-porous material that has no bulges or other design features that offer greater or equal resistance to steam penetration than a simple hollow body.

**Solid load**

The solid load specification serves to prove that the necessary sterilization conditions have been reached within the entire load with the values set in the control. The load must represent the largest weight of solid instruments for whose sterilization a steam sterilizer is designed to EN 13060.

**Sterile barrier system**

The sterile barrier system is a minimum level of sealed packaging that prevents the entry of micro-organisms (e.g. sealed pouches, sealed reusable containers, folded sterilization wipes) and allows for the aseptic delivery of the product at the point of use.

**Sterile material**

Sterile goods are successfully sterilized (i.e. sterile) goods. Sterile goods are also referred to as batches.

**Sterilization chamber**

The sterilization chamber is the part of the steam sterilizer where the load is sterilized.

**Vacuum**

Colloquially, vacuum is a space free of matter. In the technical sense, it is a volume with reduced gas pressure (mostly air pressure).

# Certificate of Suitability

According to the recommendations of the Commission for Hospital Hygiene and Infection Prevention at the Robert Koch Institute.

Manufacturer:	MELAG Medizintechnik GmbH & Co. KG
Address:	Geneststraße 6-10 10829 Berlin
Country:	Germany
Product:	Vacuclave® 550
Type of device:	Steam sterilizer
Classification:	Class IIa
Device type acc. to EN 13060:	Type B

We herewith declare that the above designated sterilizer is suited for sterilization of

- **Solid instruments (wrapped and unwrapped)**
- **Porous goods (wrapped and unwrapped)**
- **Instruments with narrow lumen (wrapped and unwrapped)**
- **Simple hollow bodies (wrapped and unwrapped)**

Instructions on load quantities and loading variants are set forth in the user manual and must be observed.

Be sure to observe the manufacturer's instructions for medical devices intended for sterilization according to EN ISO 17664-1.

We herewith declare that the following test system is suited for testing the above cited steam sterilizer.

- **MELAcontrol® Helix and MELAcontrol® Pro**

Berlin, 18.06.2024

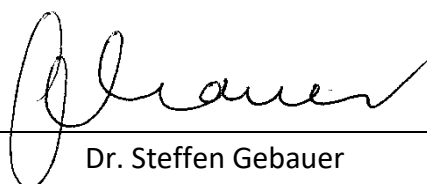

Dr. Steffen Gebauer  
(Management)





**MELAG Medizintechnik GmbH & Co. KG**

Geneststr. 6-10

D-10829 Berlin

Germany

Email: [info@melag.com](mailto:info@melag.com)

Web: [www.melag.com](http://www.melag.com)

Original instructions

Responsible for content: MELAG Medizintechnik GmbH & Co. KG

We reserve the right to technical alterations